

# CITY OF UPLAND



## CONTRACT DOCUMENTS FOR

### 11TH STREET FLASHING SIGNAL BEACON & ALLEY IMPROVEMENTS

**PROJECT No. 7031, 85003, & 86004  
BID No. 2024-05**

**CITY OF UPLAND  
Public Works Department  
Engineering Division  
1370 N. Benson Avenue  
Upland, CA 91786**

Approved:   
Engineering Manager

Date: 6/13/2024

RCE No.: 65272

Exp. Date: 9/30/2025



# TABLE OF CONTENTS

Page

<b>NOTICE INVITING BIDS.....</b>	<b>1</b>
<b>INSTRUCTIONS TO BIDDERS .....</b>	<b>5</b>
ARTICLE 1. SECURING DOCUMENTS .....	5
ARTICLE 2. EXAMINATION OF SITE AND CONTRACT DOCUMENTS .....	5
ARTICLE 3. INTERPRETATION OF DRAWINGS AND DOCUMENTS.....	5
ARTICLE 4. PRE-BID CONFERENCE .....	6
ARTICLE 5. ADDENDA .....	6
ARTICLE 6. ALTERNATE BIDS.....	6
ARTICLE 7. COMPLETION OF BID FORMS.....	6
ARTICLE 8. MODIFICATIONS OF BIDS .....	6
ARTICLE 9. SUBCONTRACTORS .....	7
ARTICLE 10. LICENSING REQUIREMENTS.....	7
ARTICLE 11. BID GUARANTEE (BOND).....	7
ARTICLE 12. IRAN CONTRACTING ACT OF 2010 .....	8
ARTICLE 13. NONCOLLUSION DECLARATION.....	8
ARTICLE 14. PUBLIC WORKS CONTRACTOR DIR REGISTRATION CERTIFICATION.....	8
ARTICLE 15. BIDDER INFORMATION AND EXPERIENCE FORM .....	8
ARTICLE 16. WORKERS' COMPENSATION CERTIFICATION .....	8
ARTICLE 17. SIGNING OF BIDS.....	8
ARTICLE 18. SUBMISSION OF SEALED BIDS .....	9
ARTICLE 19. OPENING OF BIDS .....	9
ARTICLE 20. WITHDRAWAL OF BID.....	10
ARTICLE 21. BIDDERS INTERESTED IN MORE THAN ONE BID .....	10
ARTICLE 22. SUBSTITUTION OF SECURITY.....	10
ARTICLE 23. PREVAILING WAGES .....	10
ARTICLE 24. DEBARMENT OF CONTRACTORS AND SUBCONTRACTORS.....	10
ARTICLE 25. INSURANCE REQUIREMENTS .....	11
ARTICLE 26. PERFORMANCE BOND AND PAYMENT BOND REQUIREMENTS .....	11
ARTICLE 27. SALES AND OTHER APPLICABLE TAXES, PERMITS, LICENSES AND FEES.....	11
ARTICLE 28. FILING OF BID PROTESTS .....	11
ARTICLE 29. BASIS OF AWARD; BALANCED BID .....	12
ARTICLE 30. AWARD PROCESS .....	12
ARTICLE 30. AWARD PROCESS .....	12
<b>BID FORMS .....</b>	<b>14</b>
BID ACKNOWLEDGMENT.....	14
BID SCHEDULE .....	18
BID GUARANTEE .....	22
DESIGNATION OF SUBCONTRACTORS .....	26
BIDDER INFORMATION AND EXPERIENCE FORM .....	29
NON-COLLUSION DECLARATION.....	36
IRAN CONTRACTING ACT CERTIFICATION .....	37
PUBLIC WORKS CONTRACTOR REGISTRATION CERTIFICATION.....	38
CONTRACTOR'S CERTIFICATE REGARDING WORKERS' COMPENSATION .....	39

**TABLE OF CONTENTS**  
(continued)

**Page**

<b>CONTRACT FOR CONSTRUCTION.....</b>	<b>41</b>
ARTICLE 1.    SCOPE OF WORK.....	41
ARTICLE 2.    TIME FOR COMPLETION.....	41
ARTICLE 3.    CONTRACT PRICE.....	41
ARTICLE 4.    LIQUIDATED DAMAGES.....	41
ARTICLE 5.    COMPONENT PARTS OF THE CONTRACT.....	42
ARTICLE 6.    PROVISIONS REQUIRED BY LAW AND CONTRACTOR COMPLIANCE.....	43
ARTICLE 7.    INDEMNIFICATION.....	43
ARTICLE 8.    PREVAILING WAGES.....	43
ARTICLE 9.    FALSE CLAIMS.....	43
<b>BOND FORMS.....</b>	<b>47</b>
<b>GENERAL PROVISIONS .....</b>	<b>57</b>
<b>SECTION 1    TERMS, DEFINITIONS, ABBREVIATIONS AND SYMBOLS.....</b>	<b>57</b>
1-2        Definitions.....	57
1-2.1    Terminology.....	62
1-3.3    Institutions.....	62
1-6        Bidding and Submission of the Bid.....	62
1-6.3    Availability of Plans and Specifications.....	63
1-6.4    Approximate Estimate.....	63
1-6.5    Examination of Plans, Specifications and Site of the Work.....	63
1-6.6    Proposal Form.....	63
1-6.7    Rejection of Proposals Containing Alterations or Irregularities.....	63
1-6.8    Proposal Guaranty.....	63
1-6.9    Withdrawal of Proposals.....	64
1-6.10   Disqualification of Bidders.....	64
1-6.11   Competency of Bidders.....	64
1-6.12   Material Guaranty.....	64
1-6.13   Progress Schedule.....	64
1-7        Award and Execution of the Contract.....	64
1-7.1    Consideration of Bids.....	64
<b>1-7.2    Contract Bonds</b>	
1-7.2    Contract Bonds.....	64
1-7.3    Award of Contract.....	65
1-7.4    Return of Proposal Guarantees.....	65
1-7.5    Execution of Contract.....	65
1-7.6    Evidence of Insurance.....	65
1-7.7    Contractor's Failure to Perform.....	65
1-7.8    Commencement of Contract Times; Notice to Proceed.....	66
<b>SECTION 2    SCOPE OF THE WORK.....</b>	<b>66</b>
2-4        Cooperation and Collateral Work.....	66
2-5        The Contractor's Equipment and Facilities.....	66
2-5.2    Temporary Utility Services.....	66
2-11       Substitution Requests, Schedule of Submittals, and Schedule.....	67

**TABLE OF CONTENTS**  
(continued)

	<b>Page</b>
3-3 Subcontractors.....	68
3-4 Authority of the Board and the Engineer.....	68

**TABLE OF CONTENTS**  
(continued)

		<b>Page</b>
3-5	Inspection .....	69
3-7	Contract Documents .....	69
3-7.1	General.....	69
3-7.1.1	Examination of Contract Documents; Site .....	69
3-7.1.2	Additional Instructions .....	69
3-7.1.3	Quality of Parts, Construction and Finish .....	69
3-7.1.4	Contractor's Variation from Contract Document Requirements .....	70
3-7.1.5	Intent of Contract Documents.....	70
3-7.1.6	Reference Standards .....	70
3-7.2	Precedence of the Contract Documents.....	65
3-7.3	Amending and Supplementing Contract Documents .....	65
3-7.4	Reuse of Documents .....	72
3-8	Submittals .....	72
3-8.1	General.....	72
3-8.1.1	Schedule of Submittals.....	72
3-8.1.2	Submittal Procedures .....	72
3-8.1.3	Schedule Milestone for Submittals .....	73
3-8.3	Shop Drawings .....	67
3-8.3.1	Submittal .....	74
3-8.3.2	Notice of Variations .....	75
3-8.3.3	Samples .....	75
3-8.3.4	City's Review.....	75
3-8.3.5	Resubmittal Procedures .....	75
3-9	Subsurface Data .....	75
3-10	Surveying.....	76
3-10.1	General.....	76
3-10.2	Permanent Survey Markers.....	76
3-12	Work Site Maintenance.....	77
3-12.1	General.....	77
3-12.1.1	Sanitary Facilities .....	77
3-12.1.2	Limitation of Use of Site and Other Areas .....	77
3-12.1.3	Site Maintenance.....	77
3-12.1.4	Cleaning.....	77
3-12.2	Dust and Air Pollution Control.....	78
3-12.2.1	Dust Control .....	78
3-12.2.2	Air Pollution Control.....	78
3-12.3	Noise Control.....	79
3-12.6	Water Pollution Control.....	79
3-12.6.1	General.....	79
3-13	Completion, Acceptance, and Warranty. ....	81
3-13.1	Completion. ....	81
3-13.1.1	Defective Work Correction.....	82
3-13.2	Acceptance.....	83
3-13.3	Warranty.....	83
3-14	Meetings .....	85
3-14.1	Preconstruction Conference .....	85
3-14.2	Subcontractor Mobilization Meeting.....	85
3-14.3	Progress Meetings.....	85
3-15	Record ("As-Built") Drawings .....	85

**TABLE OF CONTENTS**  
(continued)

	<b>Page</b>
3-16 Ownership of Site Materials Found.....	86
3-17 Existence of Utilities at the Work Site.....	86
3-17.1 Existing Utilities.....	86
3-17.2 Utility Location.....	87
3-17.3 Utility Relocation and Repair.....	88
3-17.4 Construction at Existing Utilities.....	89
3-18 Trenches.....	89
3-18.1 Trenches Five Feet or More in Depth.....	90
3-18.2 Excavations Deeper than Four Feet.....	90
<b>SECTION 4 CONTROL OF MATERIALS.....</b>	<b>91</b>
4-1 General.....	91
4-2 Protection.....	91
4-3 Inspection.....	93
4-3.1 General.....	93
4-4 Testing.....	94
4-9 Requests for Substitutions.....	95
<b>SECTION 5 LEGAL RELATIONS AND RESPONSIBILITIES.....</b>	<b>97</b>
5-0 General.....	97
5-1 Laws and Regulations.....	97
5-1.1 Indemnification.....	97
5-1.2 Applicable Laws.....	98
5-1.3 Permits and Licenses.....	98
5-1.4 Independent Contractors.....	98
5-1.5 Verification of Employment Eligibility.....	99
5-1.6 Public Works Contractor Registration.....	99
5-3 Labor.....	100
5-3.1 General.....	100
5-3.2 Prevailing Wage.....	100
5-3.3 Payroll Records.....	101
5-3.4 Hours of Labor.....	102
5-3.5 Apprentices.....	104
5-3.6 Nondiscrimination/ Equal Employment Opportunity.....	105
5-3.7 Debarment of Contractors and Subcontractors.....	105
5-4 Insurance.....	105
5-7 Safety.....	109
5-7.1 Work Site Safety.....	109
5-7.1.3 Responsibility.....	109
5-7.1.4 Emergency.....	110
5-7.1.5 Hazard Communication Programs.....	110
5-7.4 Hazardous Substances.....	110
5-7.4.1 Hazardous Waste.....	110
5-7.4.2 Encounter.....	110
5-7.4.3 Exposure.....	111
5-7.4.4 Indemnification.....	111
5-7.9 Traffic Control.....	111
5-8 On-Site Responsibilities.....	112

**TABLE OF CONTENTS**  
(continued)

	<b>Page</b>
5-8.1 Environmental Quality Protection .....	112
5-8.2 Diversion of Recyclable Waste Material .....	113
5-8.3 Inspector's Field Office .....	113
5-8.4 Contractor's Supervision .....	114
5-8.5 Workers .....	114
5-9 Miscellaneous .....	114
5-9.1 Taxes .....	114
5-9.2 Responsibility for Damage .....	114
5-9.3 Contractor's Responsibility for Work .....	115
5-9.4 Correction for Errors, Recovery for Errors, Dishonesty or Collusion .....	115
5-9.5 Rights in Materials and Salvage .....	115
5-9.6 Patents .....	115
5-9.7 Document Retention & Examination .....	115
5-9.8 Notice .....	116
5-9.9 Notice of Third Party Claims .....	116
5-9.10 State License Board Notice .....	116
5-9.11 Assignment of Contract .....	116
5-9.12 Change in Name and Nature of Contractor's Legal Entity .....	116
5-9.13 Prohibited Interests .....	117
5-9.14 Controlling Law .....	117
5-9.15 Jurisdiction; Venue .....	117
5-9.16 Cumulative Remedies .....	117
5-9.17 Survival of Obligations .....	117
5-9.18 Headings .....	117
5-9.19 Assignment of Antitrust Actions .....	117
5-9.20 All Legal Provisions Included .....	118
 <b>SECTION 6 PROSECUTION AND PROGRESS OF THE WORK.....</b>	 <b>111</b>
6-0 Contractor's Means and Methods .....	119
6-1 Construction Schedule and Commencement of the Work .....	119
6-1.1 Construction Schedule .....	119
6-1.1.1 General Requirements .....	119
6-1.1.2 Schedule .....	119
6-1.1.3 Schedule Contents .....	119
6-1.1.4 Schedule Updates .....	120
6-1.1.5 Acceptance .....	120
6-1.1.6 Recovery Schedule .....	120
6-1.3 Working Hours .....	121
6-3 Time of Completion .....	121
6-3.3 Time for Completion .....	121
6-4 Delays and Extension of Time .....	121
6-4.2 Extensions of Time .....	122
6-5 Use of Improvement During Construction .....	122
6-6 Suspension of the Work .....	122
6-6.1 General .....	122
6-7 Termination of the Contract for Default .....	123
6-7.1 General .....	123
6-8 Termination of the Contract for Convenience .....	124

**TABLE OF CONTENTS**  
(continued)

	<b>Page</b>
6-9 Liquidated Damages .....	126
6-10 Reverse Liquidated Damages .....	126
6-11 Force Majeure .....	127
6-12 Procedure for Time Extensions and Delay Damages .....	127
6-13 Change Orders .....	127
6-13.1 Change in Contract Procedures .....	127
6-13.1.1 City Directive .....	127
6-13.1.2 Contractor's Notice of Change/ Delay .....	127
6-13.1.3 Request for Change in Compensation and/ or Extension of Time.....	128
6-13.1.4 City's Final Decision on Change Order; Ordered Changes .....	129
6-13.1.5 Contractor's Waiver of Further Relief .....	129
6-13.1.6 Change Order Format .....	130
6-13.2 Determining Adjustments to Compensation.....	130
6-13.2.1 Limitation on Costs.....	130
6-13.2.2 Unit Price Change Orders .....	130
6-13.2.3 Lump Sum Change Orders.....	131
6-13.2.4 Time and Materials Change Orders .....	131
6-13.2.5 Federally Funded Projects.....	131
6.13.2.6 Allowed Costs.....	131
6-14 Resolving Claims.....	136
 <b>SECTION 7 MEASUREMENT AND PAYMENT .....</b>	 <b>140</b>
7-2 Lump Sum Work .....	140
7-3 Payment .....	140
7-3.1 General.....	140
7-3.1.1 Progress Estimates and Payment .....	141
7-3.2 Partial and Final Payment .....	142
7-3.2.1 Final Acceptance and Payment.....	142
7-3.4 Mobilization.....	144
7-3.5 Contract Unit Prices.....	145
7-3.9 Resolution of Construction Claims.....	146
7-4.3 Markup .....	149
7-4.3.1 Work by Contractor .....	149
7-4.3.2 Work by Subcontractor .....	149
 <b>SECTION 8 FACILITIES FOR AGENCY PERSONNEL .....</b>	 <b>149</b>
8-1 General.....	150
 <b>SECTION 9 FLEET COMPLIANCE .....</b>	 <b>149</b>

**TABLE OF CONTENTS**  
(continued)

**Page**

<b>SPECIAL PROVISIONS .....</b>	<b>151</b>
<b>SECTION 1 GENERAL REQUIREMENTS .....</b>	<b>151</b>
1.1 General .....	151
1.2 Description of Work .....	151
1.3 Utilities .....	154
1.3.1 Utility Contacts .....	152
1.3.2 Location and Protection .....	153
1.3.3 Removal .....	153
1.3.4 Compensation for Damage or Relocation .....	153
1.4 Coordination With City of Upland, other Agencies, and Utilities .....	154
1.4.1 .....	156
1.4.2 Underground Service Alert .....	157
1.4.3 Refuse Collection and Street Sweeping Services .....	157
1.4.4 Other Utility Companies .....	157
1.5 Completion and Acceptance .....	157
1.5.1 Guarantee of Work Materials .....	157
1.5.2 Liquidated Damages .....	156
1.6 Construction Start Date and Time of Completion .....	157
1.7 Work Hours .....	157
1.8 Notification of Residents and Businesses .....	157
1.9 Temporary Traffic Control .....	157
1.9.1 General Requirements .....	158
1.9.2 Pedestrians .....	160
1.9.3 Temporary Surfacing .....	163
1.9.4 Steel Plating .....	163
1.9.5 Pavement Transitions .....	163
1.9.6 Driveways .....	164
1.9.7 Parking .....	164
1.9.8 Street Lighting .....	162
1.9.9 Lane Closures .....	162
1.9.10 Road Closures .....	163
1.9.11 Temporary Striping .....	165
1.9.12 Shutdowns .....	165
1.9.13 Emergency Response .....	165
1.10 Storage of Materials and Equipment .....	164
1.11 Safeguarding of Equipment, Materials, and Work .....	164
1.12 New Materials and Equipment .....	165
1.13 Material Testing .....	165
1.14 Order of Work .....	166
1.14.1 Protection of Utilities .....	168
1.14.2 Protection of Work .....	169
1.14.3 Obstructions and Cooperation with Other Work .....	169
1.14.4 Trees .....	170
1.14.5 Sprinklers Systems and Landscaping .....	170
1.15 Changes in Work .....	169
1.16 Suspension of Work .....	169
1.17 Use of Completed Portions .....	170
1.18 Failure to Comply .....	170

**TABLE OF CONTENTS**  
(continued)

	<b>Page</b>
1.19 Noncompliance with Plans and Specifications .....	170
1.20 Site Access .....	170
1.21 Construction Water.....	170
1.22 Safety .....	171
1.23 Engineer's Estimate .....	171
1.24 Shop Drawings.....	171
1.25 Record Drawings (As-Built Drawings) .....	171
1.26 Final Cleanup .....	172
1.26.1 Cleaning and Dust Control .....	172
1.26.2 Cleanup .....	172
1.27 Permits and Licenses .....	172
1.27.1 Construction Permit .....	172
1.27.2 Partial Street or Lane Closure Permit.....	175
1.27.3 Excavation Permit.....	172
1.27.4 City of Upland Business License.....	174
1.27.5 Contractor's License .....	174
1.27.6 South Coast Air Quality Management District (SCAQMD).....	177
1.28 Preconstruction Meeting and Weekly Progress Meeting(s).....	174
1.29 Protection of Improvements .....	175
1.29.1 Removals .....	175
1.29.2 Protection of Existing Improvements.....	178
1.29.3 Protection of New Improvements .....	175
1.30 Patents and Copyrights .....	176
1.31 NPDES Requirements.....	176
1.31.1 Storm Water Pollution Prevention.....	179
1.31.2 Storm Water Pollution Prevention Plan.....	177
1.31.3 Rain Event Action Plan.....	182
1.32 Parway Restoration.....	183
 <b>SECTION 2 DEFINITION OF BID ITEMS .....</b>	 <b>182</b>
PART A – GENERAL ITEMS .....	182

**Appendix “A”**

Project Improvements Exhibit - Project No. 7031, 85003, & 96004 – 11th Street Flashing Signal Beacon & Alley Improvements.

**Appendix “B” - Required Permits and City of Upland Business License**

**Appendix “C” - Standard Drawings**

**Appendix “D” - South Coast Air Quality Management District**

**Appendix “E” - Truck Route Map**

**TABLE OF CONTENTS**  
(continued)

**Page**

**Appendix “F” - Best Management Practices (BMP)805006546**

**Appendix “G” - SCE Improvement Plans**

**Appendix “H” – Flashing Beacon Improvements Data Sheets**

## NOTICE INVITING BIDS

NOTICE IS HEREBY GIVEN that the **CITY OF UPLAND**, with its principal place of business at 460 N. Euclid Avenue Upland, California 91786 ("City") invites and will receive sealed Bids up to but not later than **3:00 p.m. on Thursday, July 11, 2024** at the Office of the **City Clerk**, located at **460 N. Euclid Avenue**, for the furnishing to City of all labor, equipment, materials, tools, services, transportation, permits, utilities, and all other items necessary for,

### **11TH STREET FLASHING SIGNAL BEACON & ALLEY IMPROVEMENTS**

#### **PROJECT No. 7031, 85003 & 86004**

#### **BID No. 2024-05**

At said time, Bids will be publicly opened and read aloud at the City Clerk's office. Bids received after said time shall be returned unopened. Bids shall be valid for a period of 90 calendar days after the Bid opening date.

The work to be performed under this Contract generally consists of electrical service conduit, service pedestal and meter, removal and disposal of existing asphalt pavement surface, cold milling, grading, compaction, and paving.

The work also includes Installation of traffic flashing beacon equipment; removal and reconstruction of Portland cement concrete (PCC) sidewalk; construction of PCC "V"-gutter; and all appurtenant work necessary for the proper construction of the contemplated improvements in accordance with the Plans and Specifications entitled 11<sup>TH</sup> STREET FLASHING SIGNAL BEACON & ALLEY IMPROVEMENTS, PROJECT No. 7031, 85003, & 86004 BID No. 2024-05.

The Contractor will furnish all transportation, materials, tools, time, equipment, labor, and supplies to complete the improvements, together with the appurtenant work necessary or incidental to complete, in a workmanlike manner, the improvements as contemplated and as intended by the Plans and these Specifications.

Bids must be submitted on City's Bid Forms. Bidders may obtain a copy of the Contract Documents from the **Public Works Department** at: **1370 N. Benson Avenue, Upland, CA 91786**, [hgonzalez@uplandca.gov](mailto:hgonzalez@uplandca.gov) or **(909) 291-2961** for **\$40**. A non-refundable charge of **\$25** will be required of any bidder who requests that the Contract Documents be mailed within California (costs for out-of-state mailings will be higher).

Bidders may also obtain a copy of the Contract Documents from <https://www.uplandca.gov/rfps-bids>. To the extent required by section 20103.7 of the Public Contract Code, upon request from a contractor plan room service, City shall provide an electronic copy of the Contract Documents at no charge to the contractor plan room.

It is the responsibility of each prospective Bidder to download and print all Bid Documents for review and to verify the completeness of Bid Documents before submitting a bid. Any Addenda will be posted on <https://www.uplandca.gov/rfps-bids>. It is the responsibility of each prospective Bidder to check the website on a daily basis through the close of Bids for any applicable Addenda or updates. City does not assume any liability or responsibility based on any defective or

incomplete copying, excerpting, scanning, faxing, emailing, downloading or printing of the Bid Documents. Information on the website may change without notice to prospective Bidders. The Contract Documents shall supersede any information posted or transmitted by the website.

Each Bid shall be accompanied by cash, a certified or cashier's check, or Bid Bond secured from a surety company satisfactory to the City, the amount of which shall not be less than ten percent (10%) of the submitted Total Bid Price, made payable to the City of Upland as bid security. The bid security shall be provided as a guarantee that within ten (10) days after City provides the successful bidder the Notice of Award, the successful Bidder will enter into a contract and provide the necessary bonds and certificates of insurance. The bid security will be declared forfeited if the successful Bidder fails to comply within said time. No interest will be paid on funds deposited with City.

All requests for information (RFI) responses shall be in written form and shall be directed and sent no later than **July 2, 2024, by 3:00 p.m.** to:

**Bob Critchfield, Engineering Manager**

**1370 N. Benson Avenue**

**Upland, CA 91786**

**(909) 291-2946**

**(909) 291-2974 Fax**

**[bcritchfield@uplandca.gov](mailto:bcritchfield@uplandca.gov)**

The successful Bidder will be required to furnish a Faithful Performance Bond and a Labor and Material Payment Bond each in an amount equal to one hundred percent (100%) of the Contract Price. Each bond shall be in the forms set forth herein, shall be secured from a surety company that meets all State of California bonding requirements, as defined in California Code of Civil Procedure Section 995.120, and that is a California admitted surety insurer.

Pursuant to Section 22300 of the Public Contract Code of the State of California, the successful Bidder may substitute certain securities for funds withheld by City to ensure its performance under the Contract.

The California Air Resources Board ("CARB") implemented amendments to the In-Use Off-Road Diesel-Fueled Fleets Regulations ("Regulation") which are effective on January 1, 2024 and apply broadly to all self-propelled off road diesel vehicles 25 horsepower or greater and other forms of equipment used in California. A copy of the Regulation is available at <https://ww2.arb.ca.gov/sites/default/files/barcu/regact/2022/off-roaddiesel/appa-1.pdf>. Bidders are required to comply with all CARB and Regulation requirements, including, without limitation, all applicable sections of the Regulation, as codified in Title 13 of the California Code of Regulations section 2449 *et seq.* throughout the term of the Project. Bidders must provide, with their Bid, copies of Bidder's and all listed subcontractors the most recent, valid Certificate of Reported Compliance ("CRC") issued by CARB. Failure to provide valid CRCs as required herein may render the Bid non-responsive.

Pursuant to Labor Code Section 1773, City has obtained the prevailing rate of per diem wages and the prevailing wage rate for holiday and overtime work applicable in San Bernardino County from the Director of the Department of Industrial Relations for each craft, classification, or type of

worker needed to execute this contract. A copy of these prevailing wage rates may be obtained via the internet at: [www.dir.ca.gov/OPRL/](http://www.dir.ca.gov/OPRL/)

In addition, a copy of the prevailing rate of per diem wages is available at City's **Office of the City Clerk** and shall be made available to interested parties upon request. The successful Bidder shall post a copy of the prevailing wage rates at each job site. It shall be mandatory upon the Bidder to whom the Contract is awarded, and upon any subcontractors, to comply with all Labor Code provisions, which include but are not limited to the payment of not less than the said specified prevailing wage rates to all workers employed by them in the execution of the Contract, employment of apprentices, hours of labor and debarment of contractors and subcontractors.

Pursuant to Labor Code sections 1725.5 and 1771.1, all contractors and subcontractors that wish to bid on, be listed in a bid proposal, or enter into a contract to perform public work must be registered with the Department of Industrial Relations. No Bid will be accepted nor any Contract entered into without proof of the contractor's and subcontractors' current registration with the Department of Industrial Relations to perform public work. If awarded a contract, the Bidder and its subcontractors, of any tier, shall maintain active registration with the Department of Industrial Relations for the duration of the Project. Notwithstanding the foregoing, the contractor registration requirements mandated by Labor Code Sections 1725.5 and 1771.1 shall not apply to work performed on a public works project that is exempt pursuant to the small project exemption specified in Labor Code Sections 1725.5 and 1771.1.

This Project is subject to compliance monitoring and enforcement by the Department of Industrial Relations. In bidding on this Project, it shall be the Bidder's sole responsibility to evaluate and include the cost of complying with all labor compliance requirements under this contract and applicable law in its Bid.

Unless otherwise provided in the Instructions for Bidders, each Bidder shall be a licensed contractor pursuant to sections 7000 et seq. of the Business and Professions Code in the following classification(s) throughout the time it submits its Bid and for the duration of the Contract:

**Class "A" License (General Engineering Contractor)**

Substitution requests shall be made within 35 calendar days after the award of the Contract. Pursuant to Public Contract Code Section 3400(b), City may make findings designating that certain additional materials, methods or services by specific brand or trade name other than those listed in the Contract Documents be used for the Project. Such findings, if any, as well as the materials, methods or services and their specific brand or trade names that must be used for the Project may be found in the Special Conditions.

Pursuant to Public Contract Code section 3400(b), if City has made any findings designating certain materials, products, things, or services by specific brand or trade name, such findings and the materials, products, things, or services and their specific brand or trade names will be set forth in the Special Conditions.

City shall award the contract for the Project to the lowest responsive, responsible Bidder as determined by City from the **BASE BID ALONE**. City reserves the right to reject any or all Bids or to waive any irregularities or informalities in any Bids or in the bidding process.

For further information, contact:

**Bob Critchfield, Engineering Manager**

**1370 N. Benson Avenue**

**Upland, CA 91786**

**(909) 291-2946**

**(909) 291-2974 Fax**

**[bcritchfield@uplandca.gov](mailto:bcritchfield@uplandca.gov)**

**END OF NOTICE INVITING BIDS**

**Publish: Friday, June 21, 2024**

**Friday, June 28, 2024**

## **INSTRUCTIONS TO BIDDERS**

### **ARTICLE 1. SECURING DOCUMENTS**

Bids must be submitted to City on the Bid Forms which are a part of the Contract Documents for the Project. Contract Documents may be obtained from as specified in the Notice Inviting Bids. Prospective Bidders are encouraged to telephone in advance to determine the availability of Contract Documents. Any charge for the Contract Documents is stated in the Notice Inviting Bids.

City may also make the Contract Documents available for review at one or more plan rooms, as indicated in the Notice Inviting Bids. Please Note: Prospective Bidders who choose to review the Contract Documents at a plan room must contact City to obtain the required Contract Documents if they decide to submit a Bid for the Project.

### **ARTICLE 2. EXAMINATION OF SITE AND CONTRACT DOCUMENTS**

At its own expense and prior to submitting its Bid, each Bidder shall visit the site of the proposed work and fully acquaint itself with the conditions relating to the construction and labor required so that the Bidder may fully understand the work, including but not limited to difficulties and restrictions attending the execution of the work under the Contract. Each Bidder shall carefully examine the Drawings, and shall read the Specifications, Contract, and all other documents referenced herein and made part of the Contract Documents. Each Bidder shall also determine the local conditions which may in any way affect the performance of the work, including local tax structure, contractors' licensing requirements, availability of required insurance, the prevailing wages and other relevant cost factors, shall familiarize itself with all federal, state and local laws, ordinances, rules, regulations and codes affecting the performance of the work, including the cost of permits and licenses required for the work, and shall make such surveys and investigations, including investigations of subsurface or latent physical conditions at the site or where work is to be performed as may be required. Bidders are responsible for consulting the standards referenced in the Contract Documents. The failure or omission of any Bidder to receive or examine the Contract Documents, forms, instruments, addenda, or other documents, or to visit the site and acquaint itself with conditions there existing shall in no way relieve any Bidder from any obligation with respect to its Bid or to the Contract and no relief for error or omission will be given except as required under state law. The submission of a Bid shall be taken as conclusive evidence of compliance with this Article.

### **ARTICLE 3. INTERPRETATION OF DRAWINGS AND DOCUMENTS**

Prospective Bidders unclear as to the true meaning of any part of the Drawings, Specifications or other Contract Documents may submit a written request for interpretation. The prospective Bidder submitting the request is responsible for prompt delivery. Interpretation of the Drawings, Specifications or other Contract Documents will be made only by a written Addendum duly issued and a copy of such Addenda will be mailed or delivered to each prospective Bidder who has purchased a set of Contract Documents. The City will not be responsible for any other explanation or interpretations of the Contract Documents. If a prospective Bidders becomes aware of any errors or omissions in any part of the Contract Documents, it is the obligation of the prospective Bidder to promptly bring it to the attention of the City.

#### **ARTICLE 4. PRE-BID CONFERENCE**

No Mandatory Pre-Bid conference is scheduled for **this project**.

#### **ARTICLE 5. ADDENDA**

The City reserves the right to revise the Contract Documents prior to the Bid opening date. Revisions, if any, shall be made by written Addenda. All Addenda issued by the City shall be included in the Bid and made part of the Contract Documents. Pursuant to Public Contract Code Section 4104.5, if the City issues an Addendum which includes material changes to the Project less than 72 hours prior to the deadline for submission of Bids, the City will extend the deadline for submission of Bids. The City may determine, in its sole discretion, whether an Addendum warrants postponement of the Bid submission date. Each prospective Bidder shall provide the City a name, address, email address, and facsimile number to which Addenda may be sent, as well as a telephone number by which the City can contact the Bidder. Copies of Addenda will be furnished by email, facsimile, first class mail, express mail or other proper means of delivery without charge to all parties who have obtained a copy of the Contract Documents and provided such current information. Please Note: Bidders are responsible for ensuring that they have received any and all Addenda. To this end, each Bidder should contact the **Public Works Department** to verify that it has received all Addenda issued, if any, prior to the Bid opening. **The Bidder shall indicate the Addenda received prior to bidding in the space provided in the Bid Form. Failure to indicate all Addenda may be sufficient cause for rejecting the Bid.**

#### **ARTICLE 6. ALTERNATE BIDS**

If alternate bid items are called for in the Contract Documents, the time required for completion of the alternate bid items has already been factored into the Contract duration and no additional Contract time will be awarded for any of the alternate bid items. The City may elect to include one or more of the alternate bid items, or to otherwise remove certain work from the Project scope of work. Accordingly, each Bidder must ensure that each Bid item contains a proportionate share of profit, overhead, and other costs or expenses which will be incurred by the Bidder.

#### **ARTICLE 7. COMPLETION OF BID FORMS**

Bids shall only be prepared using copies of the Bid Forms which are included in the Contract Documents. The use of substitute Bid Forms other than clear and correct photocopies of those provided by the City will not be permitted. Bids shall be executed by an authorized signatory as described in these Instructions to Bidders. In addition, Bidders shall fill in all blank spaces (including inserting "N/A" where applicable), and initial all interlineations, alterations, or erasures to the Bid Forms. Bidders shall neither delete, modify, nor supplement the printed matter on the Bid Forms nor make substitutions thereon. **USE OF BLACK OR BLUE INK, INDELIBLE PENCIL, OR A TYPEWRITER IS REQUIRED.** Deviations in the Bid Forms may result in the Bid being deemed non-responsive.

#### **ARTICLE 8. MODIFICATIONS OF BIDS**

Each Bidder shall submit its Bid in strict conformity with the requirements of the Contract Documents. Unauthorized additions, modifications, revisions, conditions, limitations, exclusions or provisions attached to a Bid may render it non-responsive and may cause its rejection. Bidders shall not delete, modify, or supplement the printed matter on the Bid Forms, or make substitutions thereon. Oral, telephonic and electronic modifications will not be considered.

## **ARTICLE 9. SUBCONTRACTORS**

Bidder shall set forth the name, address of the place of business, contractor license number, and public works contractor registration number of each subcontractor who will perform work, labor, furnish materials or render services to the bidder on said contract and each subcontractor licensed by the State of California who, under subcontract to bidder, specially fabricates and installs a portion of the Work described in the Contract Documents in an amount in excess of one half of one percent (0.5%) of the total bid price, and shall indicate the portion of the work to be done by such subcontractor in accordance with Public Contract Code Section 4104. Notwithstanding the foregoing, if the work involves the construction of streets and highways, then the Bidder shall list each subcontractor who will perform work or labor or render service to the Bidder in or about the work in an amount in excess of one-half of one percent (0.5%) of the Bidder's Total Bid Price or \$10,000, whichever is greater. If a Bidder fails to specify a subcontractor or if a Bidder specifies more than one subcontractor for the same portion of work, then the Bidder shall be deemed to have agreed that it is fully qualified to perform that portion of work and that it shall perform that portion itself. Substitution of listed subcontractors shall only be permitted in accordance with Public Contract Code Section 4107.

## **ARTICLE 10. LICENSING REQUIREMENTS**

Pursuant to Business and Professions Code Section 7028.15 and Public Contract Code Section 3300, all Bidders must possess proper licenses for performance of this Contract. Subcontractors must possess the appropriate licenses for each specialty subcontracted. Pursuant to Business and Professions Code Section 7028.5, the City shall consider any Bid submitted by a Bidder not currently licensed in accordance with state law and pursuant to the requirements found in the Contract Documents to be nonresponsive, and the City shall reject the Bid. The City shall have the right to request, and Bidders shall provide within ten (10) calendar days, evidence satisfactory to the City of all valid license(s) currently held by that Bidder and each of the Bidder's subcontractors, before awarding the Contract.

Notwithstanding anything contained herein, if the Work involves federal funds, the Contractor shall be properly licensed by the time the Contract is awarded, pursuant to the provisions of Public Contract Code section 20103.5.

## **ARTICLE 11. BID GUARANTEE (BOND)**

Each Bid shall be accompanied by: (a) cash; (b) a certified or cashier's check made payable to the **City of Upland**; or (c) a Bid Bond secured from a surety company satisfactory to the City, the amount of which shall not be less than ten percent (10%) of the Total Bid Price, made payable to the **City of Upland** as bid security. Personal sureties and unregistered surety companies are unacceptable. The surety insurer shall be California admitted surety insurer, as defined in Code of Civil Procedure Section 995.120. The bid security shall be provided as a guarantee that within ten (10) Days after the City provides the successful Bidder the Notice of Award, the successful Bidder will enter into a Contract and provide the necessary bonds and certificates of insurance. The bid security will be declared forfeited if the successful Bidder fails to comply within said time, and the City may enter into a Contract with the next lowest responsive responsible bidder, or may call for new Bids. No interest shall be paid on funds deposited with the City. The City will return the security accompanying the Bids of all unsuccessful Bidders no later than 60 calendar days after award of the contract.

## **ARTICLE 12. IRAN CONTRACTING ACT OF 2010**

In accordance with Public Contract Code Section 2200 *et seq.*, the City requires that any person that submits a Bid with the City of one million dollars (\$1,000,000) or more, certify at the time the Bid is submitted that the person is not identified on a list created pursuant to subdivision (b) of Public Contract Code Section 2203 as a person engaging in investment activities in Iran described in subdivision (a) of Public Contract Code Section 2202.5, or as a person described in subdivision (b) of Public Contract Code Section 2202.5, as applicable.

The form of such Iran Contracting Certificate is included with the Bid Forms and must be signed and dated under penalty of perjury.

## **ARTICLE 13. NONCOLLUSION DECLARATION**

Bidders on all public works contracts are required to submit a declaration of noncollusion with their Bid. This form is included with the Bid Forms and must be signed and dated under penalty of perjury.

## **ARTICLE 14. PUBLIC WORKS CONTRACTOR DIR REGISTRATION CERTIFICATION**

Pursuant to Labor Code sections 1725.5 and 1771.1, all contractors and subcontractors that wish to bid on, be listed in a bid proposal, or enter into a contract to perform public work must be registered with the Department of Industrial Relations. No Bid will be accepted nor any Contract entered into without proof of the contractor's and subcontractors' current registration with the Department of Industrial Relations to perform public work. If awarded a contract, the Bidder and its subcontractors, of any tier, shall maintain active registration with the Department of Industrial Relations for the duration of the Project. To this end, Bidder shall sign and submit with its Bid the Public Works Contractor DIR Registration Certification on the form provided, attesting to the facts contained therein. Failure to submit this form may render the bid non-responsive. In addition, each Bidder shall provide the registration number for each listed subcontractor in the space provided in the Designation of Subcontractors form.

## **ARTICLE 15. BIDDER INFORMATION AND EXPERIENCE FORM**

Each Bidder shall complete the questionnaire provided herein and shall submit the questionnaire along with its Bid. Failure to provide all information requested within the questionnaire along with the Bid may cause the bid to be rejected as non-responsive. The City reserves the right to reject any Bid if an investigation of the information submitted does not satisfy the City that the Bidder is qualified to properly carry out the terms of the Contract.

## **ARTICLE 16. WORKERS' COMPENSATION CERTIFICATION**

In accordance with the provisions of Labor Code Section 3700, Contractor shall secure the payment of compensation to its employees. Contractor shall sign and file with the City a Workers' Compensation Certificate prior to performing the work under this Contract. The form of such Workers' Compensation Certificate is included as part of the Bid Forms.

## **ARTICLE 17. SIGNING OF BIDS**

All Bids submitted shall be executed by the Bidder or its authorized representative. Bidders may be asked to provide evidence in the form of an authenticated resolution of its Board of

Directors or a Power of Attorney evidencing the capacity of the person signing the Bid to bind the Bidder to each Bid and to any Contract arising therefrom.

If a Bidder is a joint venture or partnership, it may be asked to submit an authenticated Power of Attorney executed by each joint venturer or partner appointing and designating one of the joint venturers or partners as a management sponsor to execute the Bid on behalf of Bidder. Only that joint venturer or partner shall execute the Bid. The Power of Attorney shall also: (1) authorize that particular joint venturer or partner to act for and bind Bidder in all matters relating to the Bid; and (2) provide that each venturer or partner shall be jointly and severally liable for any and all of the duties and obligations of Bidder assumed under the Bid and under any Contract arising therefrom. The Bid shall be executed by the designated joint venturer or partner on behalf of the joint venture or partnership in its legal name.

**ARTICLE 18. SUBMISSION OF SEALED BIDS**

Once the Bid and supporting documents have been completed and signed as set forth herein, they shall be placed, along with the Bid guarantee and other required materials, in a sealed envelope, addressed and delivered or mailed, postage prepaid, to the Public Works Department of the City before the time and day set for the receipt of Bids. The envelope shall bear the title of the work and the name of the Bidder. No oral or telephonic bids will be considered. No forms transmitted via the internet, e-mail, facsimile, or any other electronic means will be considered unless specifically authorized by the City as provided herein. Bids received after the time and day set for the receipt of Bids shall be returned to the Bidder unopened. The envelope shall also contain the following thereof:

<b>Bid of</b>	<b>(Bidder's Name)</b>
<hr/>	
	<b>PROJECT No. 7031, 85003, &amp; 86004</b>
<b>for the</b>	<b>BID No. 2023-05</b>
	<b>11TH STREET FLASHING SIGNAL BEACON &amp; ALLEY IMPROVEMENTS</b>

Only where expressly permitted in the Notice Inviting Bids may bidders submit their bids via electronic transmission pursuant to Public Contract Code sections 1600 and 1601. Any acceptable method(s) of electronic transmission shall be stated in the Notice Inviting Bids. The City may reject any Bid not strictly complying with the City's designated methods for delivery.

**ARTICLE 19. OPENING OF BIDS**

At the time and place set for the opening and reading of Bids, or any time thereafter, each and every Bid received prior to the time and day set for the receipt of Bids will be publicly opened and read. The City will leave unopened any Bid received after the specified date and time, and any such unopened Bid will be returned to the Bidder. It is the Bidder's sole responsibility to ensure that its Bid is received as specified. Bids may be submitted earlier than the date(s) and time(s) indicated.

The public reading of each Bid will include the following information:

- A. The name and business location of the Bidder.
- B. The nature and amount of the bid security furnished by Bidder.
- C. The Bid amount.

Bidders or their representatives and other interested persons may be present at the opening of the Bids. The City may, in its sole discretion, elect to postpone the opening of the submitted Bids. The City reserves the right to reject any or all Bids and to waive any informality or irregularity in any Bid.

#### **ARTICLE 20. WITHDRAWAL OF BID**

Any Bid may be withdrawn either personally or by written request, incurring no penalty, at any time prior to the scheduled closing time for receipt of Bids. Requests to withdraw Bids shall be worded so as not to reveal the amount of the original Bid. Withdrawn Bids may be resubmitted until the time and day set for the receipt of Bids, provided that resubmitted Bids are in conformance with the instructions herein.

Bids may be withdrawn after Bid opening only by providing written notice to the City within five (5) working days of the Bid opening and in compliance with Public Contract Code Section 5100 *et seq.*, or as otherwise may be allowed with the consent of the City.

#### **ARTICLE 21. BIDDERS INTERESTED IN MORE THAN ONE BID**

No Bidder shall be allowed to make, file or be interested in more than one Bid for the same work unless alternate Bids are specifically called for. A person, firm or corporation that has submitted a sub-proposal to a Bidder, or that has quoted prices of materials to a Bidder, is not thereby disqualified from submitting a sub-proposal or quoting prices to other Bidders or from simultaneously submitting its own Bid as a prime contractor.

#### **ARTICLE 22. SUBSTITUTION OF SECURITY**

The Contract Documents call for monthly progress payments for the Work completed. The City will retain a percentage of each progress payment as provided by the Contract Documents. At the request and expense of the successful Bidder, the City will substitute securities for the amount so retained in accordance with Public Contract Code Section 22300.

#### **ARTICLE 23. PREVAILING WAGES**

The City has obtained from the Director of the Department of Industrial Relations the general prevailing rate of per diem wages in the locality in which this work is to be performed for each craft or type of worker needed to execute the Contract. These rates are available at the **Office of the City Clerk** of the City or may be obtained online at <http://www.dir.ca.gov>. Bidders are advised that a copy of these rates must be posted by the successful Bidder at the job site(s).

#### **ARTICLE 24. DEBARMENT OF CONTRACTORS AND SUBCONTRACTORS**

In accordance with the provisions of the Labor Code, contractors or subcontractors may not perform work on a public works project with a subcontractor who is ineligible to perform work on a public project pursuant to Labor Code Sections 1777.1 or 1777.7. Any contract on a public

works project entered into between a contractor and a debarred subcontractor is void as a matter of law. A debarred subcontractor may not receive any public money for performing work as a subcontractor on a public works contract. Any public money that is paid to a debarred subcontractor by the Contractor for the Project shall be returned to the City. The Contractor shall be responsible for the payment of wages to workers of a debarred subcontractor who has been allowed to work on the Project.

## **ARTICLE 25. INSURANCE REQUIREMENTS**

Prior to commencing work, the successful bidder shall purchase and maintain insurance as set forth in the General Conditions.

## **ARTICLE 26. PERFORMANCE BOND AND PAYMENT BOND REQUIREMENTS**

The successful Bidder will be required to furnish a Labor and Material Payment Bond and a Faithful Performance Bond each in an amount equal to one hundred percent (100%) of the contract price. Each bond shall be secured from a surety company that meets all State of California bonding requirements, as defined in California Code of Civil Procedure Section 995.120 and is admitted by the State of California. Each bond shall be accompanied, upon the request of the City, with all documents required by California Code of Civil Procedure Section 995.660 to the extent required by law. All bonding and insurance requirements shall be completed and submitted to the City within ten (10) Days from the date the City provides the successful bidder with the Notice of Award.

## **ARTICLE 27. SALES AND OTHER APPLICABLE TAXES, PERMITS, LICENSES AND FEES**

Contractor and its subcontractors performing work under this Contract will be required to pay California sales tax and other applicable taxes, and to pay for permits, licenses and fees required by the agencies with authority in the jurisdiction in which the Work will be located, unless otherwise expressly provided by the Contract Documents.

## **ARTICLE 28. FILING OF BID PROTESTS**

Bidders may file a "protest" of a Bid with the City's Representative. In order for a Bidder's protest to be considered valid, the protest must:

- A.** Be filed in writing within five (5) calendar days after the bid opening date or any City determination or recommendation regarding the Bidder's bid;
- B.** Clearly identify the specific irregularity or accusation;
- C.** Clearly identify the specific City staff determination or recommendation being protested;
- D.** Specify in detail the grounds for protest and the facts supporting the protest; and
- E.** Include all relevant, supporting documentation with the protest at time of filing.

If the protest does not comply with each of these requirements, the City may reject the protest without further review.

If the protest is timely and complies with the above requirements, the City's Representative, or

other designated City staff member, shall review the protest, any response from the challenged Bidder(s), and all other relevant information. The City's Representative will provide a written decision to the protestor.

The procedure and time limits set forth in this Article are mandatory and are the sole and exclusive remedy in the event of a Bid protest. Failure to comply with these procedures shall constitute a failure to exhaust administrative remedies and a waiver of any right to further pursue the Bid protest, including filing a Government Code Claim or legal proceedings.

#### **ARTICLE 29. BASIS OF AWARD; BALANCED BID**

The City shall award the Contract to the lowest responsible Bidder submitting a responsive Bid. The lowest Bid will be determined on the basis of the Total Bid Price.

The City may reject any Bid which, in its opinion when compared to other Bids received or to the City's internal estimates, does not accurately reflect the cost to perform the Work. The City may reject as non-responsive any Bid which unevenly weights or allocates costs, including but not limited to overhead and profit to one or more particular bid items.

#### **ARTICLE 30. AWARD PROCESS**

Once all Bids are opened and reviewed to determine the lowest responsive and responsible Bidder, the City Council may award the Contract. The apparent successful Bidder should begin to prepare the following documents: (1) the Performance Bond; (2) the Payment Bond; and (3) the required insurance certificates and endorsements. Once the City notifies the Bidder of the award, the Bidder will have ten (10) days from the date of this notification to execute the Contract and supply the City with all of the required documents and certifications. Once the City receives all of the properly drafted and executed documents and certifications from the Bidder, the City will issue a Notice to Proceed to that Bidder.

#### **ARTICLE 31. EXECUTION OF CONTRACT**

As required herein the Bidder to whom an award is made shall execute the Contract in the amount determined by the Contract Documents. The City may require appropriate evidence that the persons executing the Contract are duly empowered to do so. The Contract and bond forms to be executed by the successful Bidder are included within these Contract Documents and shall not be detached.

## ARTICLE 32. QUESTIONS

Questions regarding this Notice Inviting Bids may be directed to **Bob Critchfield, Engineering Manager** at **(909) 291-2946** or email at **[bcritchfield@uplandca.gov](mailto:bcritchfield@uplandca.gov)**. No other members of the City's staff or City Council should be contacted about this procurement during the bidding process. Any and all inquiries and comments regarding this Bid must be communicated in writing, unless otherwise instructed by the City. The City may, in its sole discretion, disqualify any Bidder who engages in any prohibited communications.

**BID FORMS**

**BID ACKNOWLEDGMENT**

Bids will be received at the **Office of the City Clerk** until **3:00 p.m. on Thursday, July 11, 2024.**

**PROJECT No. 7031, 85003 & 86004**

**BID No. 2023-05**

**11TH STREET FLASHING SIGNAL BEACON & ALLEY IMPROVEMENTS**

**NAME OF BIDDER:** \_\_\_\_\_

To the **CITY OF UPLAND** , with its principal place of business at 460 N. Euclid Avenue Upland, CA 91786.

- F.** In response to the Notice Inviting Bids dated **June 21, 2024**, and in accordance with the accompanying Instructions to Bidders, the undersigned hereby proposes to the City to furnish all labor, technical and professional services, supervision, materials and equipment, other than materials and equipment specified as furnished by the City, and to perform all operations necessary and required to construct the Project in accordance with the provisions of the Contract Documents and any addenda thereto, and at the prices stated opposite the respective items set forth in the Bid Schedule.
- G.** This Bid constitutes a firm offer to the City which cannot be withdrawn for 90 days after the date set for opening of Bids, or until a Contract is executed by the City and a third party, whichever is earlier.
- H.** The undersigned certifies that it has examined and is fully familiar with all of the provisions of the Contract Documents and any addenda thereto; that it has carefully checked all of the words and figures shown in its Bid Schedule; that it has carefully reviewed the accuracy of all statements in this Bid and attachments hereto; and that it understands and agrees that the City will not be responsible for any errors or omissions on the part of the undersigned in preparing this Bid.
- I.** If awarded a Contract, the undersigned agrees to execute and deliver to the City within ten (10) days after date of receipt of Notice of Award, a signed Contract and the necessary Performance Bond, Payment Bond, and Certificates of Insurance and Endorsements.

J. The following Bid Forms, which have been completed and executed by the undersigned Bidder, are incorporated by this reference and made a part of this Bid:

1. Bid Schedule
2. Bid Guarantee in the amount of not less than 10% of the Total Bid Price.
3. Completed Designation of Subcontractors form.
4. Fully executed Non-collusion Declaration form.
5. Completed Iran Contracting Act Certification form.
6. Completed Public Works Contractor DIR Registration Certification form.
7. Completed Contractor's Certificate Regarding Workers' Compensation form.
8. Completed Bidder Information and Experience Form.

K. The undersigned is hereby representing that it is and will be properly licensed both at the time that it submits a Bid as well as at the time the Contract is awarded, if the Contract is awarded to the undersigned.

1. Individual Contractor. Undersigned certifies that it is now licensed in accordance with the provisions of the Contractor's License Law of the State of California.

License number \_\_\_\_\_

Expiration date \_\_\_\_\_

License classification \_\_\_\_\_

1. Joint Venture. Undersigned certifies that the individual members of the joint venture are now licensed in accordance with the provisions of the Contractor's License Law of the State of California.

Member No. 1

Name \_\_\_\_\_

License number \_\_\_\_\_

Expiration date \_\_\_\_\_

License classification \_\_\_\_\_

Member No. 2

Name \_\_\_\_\_

License number \_\_\_\_\_

Expiration date \_\_\_\_\_

License classification \_\_\_\_\_

(If there are more than two members of the joint venture, attach a page for the additional member(s) with the above information.)

The undersigned acknowledges receipt, understanding, and full consideration of the following addenda to the Contract Documents:

Addenda No. \_\_\_\_\_

**[SIGNATURE ON FOLLOWING PAGE]**

I hereby certify under penalty of perjury under the laws of the State of California that all of the information submitted in connection with this Bid and all of the representations made herein are true and correct.

BIDDER:

Bidder's Business Address:

\_\_\_\_\_  
(Company Name)

\_\_\_\_\_  
\_\_\_\_\_  
\_\_\_\_\_

By \_\_\_\_\_  
(Signature)

\_\_\_\_\_  
(Type or print name)

\_\_\_\_\_  
(Title)

\_\_\_\_\_  
(Where signed) (City, State)

(corporate seal)

Dated: \_\_\_\_\_, 20\_\_\_\_\_  
State of Incorporation: \_\_\_\_\_

*(If the Prime Contractor is a corporation, two signatures of corporate officers are required. Attach a page for second signature if needed)*

Names and addresses of all partners or joint venturers:

\_\_\_\_\_  
\_\_\_\_\_  
\_\_\_\_\_

Statement of the authority of signatory to bind Bidder:

\_\_\_\_\_  
\_\_\_\_\_  
\_\_\_\_\_

## BID SCHEDULE

### 11TH STREET FLASHING SIGNAL BEACON & ALLEY IMPROVEMENTS

Name of Bidder: \_\_\_\_\_

The undersigned, having examined the proposed Contracts and having visited the site and examined the conditions affecting the work, hereby and agrees to furnish all labor, materials, equipment, and appliances, and perform operations necessary to complete the work as required by said proposed Contract Documents, excluding work of alternates for.

#### BASE BID

ITEM NO.	DESCRIPTION	QUANTITY	UNIT	UNIT PRICE	ITEM COST (Subtotal)
<b>PART A – GENERAL ITEMS (1-5)</b>					
1	Traffic/Pedestrian Control, Public Convenience and Safety.	1	LS	\$	\$
2	Construction Surveying.	1	LS	\$	\$
3	Storm Water Pollution Prevention Plan & Implementation.	1	LS	\$	\$
4	Potholing and Utility Verification. Supply Potholing Data to City Engineer.	1	LS	\$	\$
5	Clearing and Grubbing.	1	LS	\$	\$
<b>PART B – STREET IMPROVEMENT (ITEMS 6-11)</b>					
6	Unclassified Excavation and Subgrade Preparation.	57	CY	\$	\$
7	Construct 8" PCC Alley 'V' Gutter	600	SF	\$	\$
8	Remove and Reconstruct PCC Alley Intersection.	280	SF	\$	\$
9	Remove and Reconstruct 4" Thick PCC Sidewalk.	280	SF	\$	\$
10	Construct 2.5-inch Thick AC Base Course Type B PG 64-10.	59	TON	\$	\$
11	Construct 1.5-inch Thick AC Type C2 PG 64-10.	36	TON	\$	\$
<b>PART C – FLASHING BEACON IMPROVEMENTS (ITEMS 12-15)</b>					
12	Furnish and Install PVC Electrical Conduits per Final SCE Plans	300	LF	\$	\$

ITEM NO.	DESCRIPTION	QUANTITY	UNIT	UNIT PRICE	ITEM COST (Subtotal)
13	Furnish and Install Electrical Bull Box	1	EA	\$	\$
14	Furnish and Install Electrical Service with Foundation	1	EA	\$	\$
15	Furnish and Install Flashing Beacon Equipment	2	EA	\$	\$
<b>TOTAL BASE BID</b>  <b>(ITEMS 1-15)</b>	(In Figures)			\$	
	(In Words) _____				

**The basis for award of contract shall be the Contractor's Base Bid only.**

TOTAL BASE BID PRICE BASED ON BID SCHEDULE	
\$	_____
Total Base Bid in Figures	

The costs for any Work shown or required in the Contract Documents, but not specifically identified as a line item are to be included in the related line items and no additional compensation shall be due to Contractor for the performance of the Work.

All blank spaces appearing above must be filled in. Failure to fill in any blank spaces may render the bid non-responsive. In case of discrepancy between the Unit Price and Item Cost set forth for a unit basis item, the Unit Price shall prevail and be utilized as the basis for determining the lowest responsive, responsible Bidder. However, if the amount set forth as a Unit Price is ambiguous, unintelligible or uncertain for any cause, or is omitted, or is the same amount as the entry in the Item Cost column, then the amount set forth in the Item Cost column for the item shall prevail and shall be divided by the estimated quantity for the item and the price thus obtained shall be the Unit Price.

For purposes of evaluating Bids, the City will correct any apparent errors in the extension of unit prices and any apparent errors in the addition of lump sum and extended prices.

The estimated quantities for Unit Price items are for purposes of comparing Bids only and the City makes no representation that the actual quantities of work performed will not vary from the estimates. Final payment shall be determined by the Engineer from measured quantities of work performed based upon the Unit Price.

The undersigned agrees that this Bid Schedule constitutes a firm offer to the City which cannot be withdrawn for the number of calendar days indicated in the Notice Inviting Bids from and after the Bid opening, or until a Contract for the Work is fully executed by the City and a third party, whichever is earlier.

If the Contract Documents specify Alternate Bid items, the City can choose to include any, all, or none of the Alternate Bid items in the Work. If the City selects any of the Alternate Bid items, the corresponding Alternate Bid prices shall be added to or deducted from Base Bid Price for the Work. The City can award/select Alternate Bid items at any time(s).

NOTES:

1. Determination of the lowest bidder will be based upon the **“TOTAL BASE BID”** price indicated in the Bid Schedule above.
2. All amounts and totals given in the Bid Schedule will be subject to verification by the Contractor. In case of variation between the unit cost and amount shown by bidder, the unit cost will be considered to be his/her bid.
3. The price bid shall include all State, Federal, and other taxes applicable to the project, and shall be a firm offer for a period of 90 calendar days after the date of bid opening.
4. Acknowledge receipt of all Addenda. The cover sheet of each addendum issued is signed by the Contractor and attached herewith.
5. Unbalanced bids will be considered sufficient grounds for rejection of the entire bid. An unbalanced bid is defined as a bid containing lump sum or unit bid items which do not reasonably reflect actual costs, plus reasonable share of the anticipated profits, overhead costs, and other indirect costs attributable to the performance of the work in question.
6. The quantities listed in the above Bid Form are estimates shown for bid comparison only. Payment will be made at the Contract Unit Price for the actual quantities constructed, based upon field measurements or certified weight tickets where appropriate. The City does not, expressly or by implication, agree that the actual amount of work will correspond therewith, and reserves the right to increase or decrease the amount of any class or portion of the work, or to omit portions of the work, as may be deemed necessary or advisable by the Engineer. In case of variation between the unit cost and amount shown by bidder, the unit cost will be considered to be his/her bid.
7. The City reserves the right to delete one or more bid items, and/or to increase or decrease the quantities of any bid item.
8. \*Indicates bid item that may or may not be used.

The undersigned, under penalty of perjury, acknowledges that they are authorized by the bidding Contractor to submit a bid for said Contractor

Respectfully submitted:

Name of Bidder \_\_\_\_\_

Signature \_\_\_\_\_

Name and Title \_\_\_\_\_

Dated \_\_\_\_\_

**BID GUARANTEE**

**BID BOND**

[Note: Not required when other form of Bidder's Security, e.g. cash, certified check or cashier's check, accompanies Bid.]

The makers of this bond are, \_\_\_\_\_, as Principal, and \_\_\_\_\_, as Surety and are held and firmly bound unto the CITY OF UPLAND , with its principal place of business at 460 N. Euclid Avenue, Upland, California 91786, hereinafter called the City, in the penal sum of TEN PERCENT (10%) OF THE TOTAL BID PRICE of the Principal submitted to the City for the work described below, for the payment of which sum in lawful money of the United States, well and truly to be made, we bind ourselves, our heirs, executors, administrators, successors and assigns, jointly and severally, firmly by these presents.

THE CONDITION OF THIS OBLIGATION IS SUCH that whereas the Principal has submitted the accompanying bid dated \_\_\_\_\_, 20 \_\_\_\_, for **PROJECT No. 7031, 85003, & 96004 11th Street Flashing Signal Beacon & Alley Improvements.**

If the Principal does not withdraw its Bid within the time specified in the Contract Documents; and if the Principal is awarded the Contract and provides all documents to the City as required by the Contract Documents; then this obligation shall be null and void. Otherwise, this bond will remain in full force and effect.

Surety, for value received, hereby stipulates and agrees that no change, extension of time, alteration or addition to the terms of the Contract Documents shall affect its obligation under this bond, and Surety does hereby waive notice of any such changes.

In the event a lawsuit is brought upon this bond by the City and judgment is recovered, the Surety shall pay all litigation expenses incurred by the City in such suit, including reasonable attorneys' fees, court costs, expert witness fees and expenses.

IN WITNESS WHEREOF, the above-bound parties have executed this instrument under their several seals this \_\_\_\_\_ day of \_\_\_\_\_, 20\_\_\_\_, the name and corporate seal of each corporation.

(Corporate Seal)

\_\_\_\_\_  
Contractor/ Principal

By \_\_\_\_\_

Title \_\_\_\_\_

\_\_\_\_\_

(Corporate Seal)

Surety

By \_\_\_\_\_  
Attorney-in-Fact

(Attach Attorney-in-Fact Certificate)  
THIS IS A REQUIRED FORM

Title \_\_\_\_\_

Any claims under this bond may be addressed to:

(Name and Address of Surety) \_\_\_\_\_  
\_\_\_\_\_  
\_\_\_\_\_

(Name and Address of Agent or Representative for service of process in California, if different from above) \_\_\_\_\_  
\_\_\_\_\_  
\_\_\_\_\_

(Telephone number of Surety and Agent or Representative for service of process in California) \_\_\_\_\_

# Notary Acknowledgment

A notary public or other officer completing this certificate verifies only the identity of the individual who signed the document to which this certificate is attached, and not the truthfulness, accuracy, or validity of that document.

STATE OF CALIFORNIA  
 COUNTY OF \_\_\_\_\_

On \_\_\_\_\_, 20\_\_\_\_, before me, \_\_\_\_\_, Notary Public, personally appeared \_\_\_\_\_, who proved to me on the basis of satisfactory

Name(s) of Signer(s)

evidence to be the person(s) whose name(s) is/are subscribed to the within instrument and acknowledged to me that he/she/they executed the same in his/her/their authorized capacity(ies), and that by his/her/their signature(s) on the instrument the person(s), or the entity upon behalf of which the person(s) acted, executed the instrument.

I certify under PENALTY OF PERJURY under the laws of the State of California that the foregoing paragraph is true and correct.

WITNESS my hand and official seal.

\_\_\_\_\_  
 Signature of Notary Public

### OPTIONAL

*Though the information below is not required by law, it may prove valuable to persons relying on the document and could prevent fraudulent removal and reattachment of this form to another document.*

#### CAPACITY CLAIMED BY SIGNER

- Individual
- Corporate Officer

Title(s)

- Partner(s)
  - Limited
  - General
- Attorney-In-Fact
- Trustee(s)
- Guardian/Conservator
- Other:

Signer is representing:  
 Name Of Person(s) Or Entity(ies)

\_\_\_\_\_  
 \_\_\_\_\_

#### DESCRIPTION OF ATTACHED DOCUMENT

Title or Type of Document

Number of Pages

Date of Document

\_\_\_\_\_  
 Signer(s) Other Than Named Above

NOTE: This acknowledgment is to be completed for Contractor/Principal.



## DESIGNATION OF SUBCONTRACTORS

The subcontractor listed below will perform work or labor or render service to the contractor in or about the construction of the work or improvement, or are subcontractors licensed by the State of California who will, under subcontract to the contractor, specially fabricate and install a portion of the work or improvement according to detailed drawings contained in the Contract Documents, in an amount in excess of one-half of one percent (1/2 of 1%) of the contractor's total bid. Notwithstanding the foregoing, if the work involves the construction of streets and highways, then the Bidder shall list each subcontractor who will perform work or labor or render service to the Bidder in or about the work in an amount in excess of one-half of one percent (0.5%) of the Bidder's Total Bid Price or \$10,000, whichever is greater. No additional time shall be granted to provide the below requested information.

In compliance with the Subletting and Subcontracting Fair Practices Act Chapter 4 (commencing at Section 4100), Part 1, Division 2 of the California Public Contract Code, the Bidder shall set forth below:

- (a) The portion of the work to be done by the subcontractor;
- (b) The name and the location of the place of business;
- (c) The California contractor license number; and
- (d) The DIR public works contractor registration number.

If a Bidder fails to specify a subcontractor or if a Bidder specifies more than one subcontractor for the same portion of work, then the Bidder shall be deemed to have agreed that it is fully qualified to perform that portion of work and that it shall perform that portion itself.

Portion of Work to be done by Subcontractor	Name of Subcontractor	Location of Business	CSLB Contractor License No.	DIR Registration Number

Portion of Work to be done by Subcontractor	Name of Subcontractor	Location of Business	CSLB Contractor License No.	DIR Registration Number

Portion of Work to be done by Subcontractor	Name of Subcontractor	Location of Business	CSLB Contractor License No.	DIR Registration Number

(Attach additional sheets if necessary)

Name of Bidder \_\_\_\_\_

Signature \_\_\_\_\_

Name and Title \_\_\_\_\_

Dated \_\_\_\_\_

**BIDDER INFORMATION AND EXPERIENCE FORM**

**A. INFORMATION ABOUT BIDDER**

(Indicate not applicable (“N/A”) where appropriate.)

NOTE: Where Bidder is a joint venture, pages shall be duplicated and information provided for all parties to the joint venture.

1.0 Name of Bidder: \_\_\_\_\_

2.0 Type, if Entity: \_\_\_\_\_

3.0 Bidder Address: \_\_\_\_\_

\_\_\_\_\_

Facsimile Number Telephone Number

\_\_\_\_\_

Email Address

4.0 How many years has Bidder’s organization been in business as a Contractor?

\_\_\_\_\_

5.0 How many years has Bidder’s organization been in business under its present name? \_\_\_\_\_

5.1 Under what other or former names has Bidder’s organization operated? \_\_\_\_\_

6.0 If Bidder’s organization is a corporation, answer the following:

6.1 Date of Incorporation: \_\_\_\_\_

6.2 State of Incorporation: \_\_\_\_\_

6.3 President’s Name: \_\_\_\_\_

6.4 Vice-President’s Name(s): \_\_\_\_\_

\_\_\_\_\_

6.5 Secretary’s Name: \_\_\_\_\_

6.6 Treasurer’s Name: \_\_\_\_\_

7.0 If an individual or a partnership, answer the following:

7.1 Date of Organization: \_\_\_\_\_

7.2 Name and address of all partners (state whether general or limited partnership):

\_\_\_\_\_  
\_\_\_\_\_  
\_\_\_\_\_

8.0 If other than a corporation or partnership, describe organization and name principals:

\_\_\_\_\_  
\_\_\_\_\_

9.0 List other states in which Bidder's organization is legally qualified to do business.

\_\_\_\_\_  
\_\_\_\_\_  
\_\_\_\_\_

10.0 What type of work does the Bidder normally perform with its own forces?

\_\_\_\_\_  
\_\_\_\_\_

11.0 Has Bidder ever failed to complete any work awarded to it? If so, note when, where, and why:

\_\_\_\_\_  
\_\_\_\_\_

12.0 Within the last five years, has any officer or partner of Bidder's organization ever been an officer or partner of another organization when it failed to complete a contract? If so, attach a separate sheet of explanation:

\_\_\_\_\_  
\_\_\_\_\_

13.0 List Trade References:

---

---

---

---

14.0 List Bank References (Bank and Branch Address):

---

---

---

---

15.0 Name of Bonding Company and Name and Address of Agent:

---

---

---

**[REMAINDER OF THIS PAGE INTENTIONALLY LEFT BLANK]**





**D. EXPERIENCE AND TECHNICAL QUALIFICATIONS QUESTIONNAIRE**

**Personnel:**

The Bidder shall identify the key personnel to be assigned to this project in a management, construction supervision or engineering capacity.

1. List each person's job title, name and percent of time to be allocated to this project:

---

---

---

2. Summarize each person's specialized education:

---

---

---

3. List each person's years of construction experience relevant to the project:

---

---

---

4. Summarize such experience:

---

---

---

Bidder agrees that personnel named in this Bid will remain on this Project until completion of all relevant Work, unless substituted by personnel of equivalent experience and qualifications approved in advance by the City.

**E. ADDITIONAL BIDDER'S STATEMENTS:**

If the Bidder feels that there is additional information which has not been included in the questionnaire above, and which would contribute to the qualification review, it may add that information in a statement here or on an attached sheet, appropriately marked:

---

---

---

---

---

---

Name of Bidder \_\_\_\_\_

Signature \_\_\_\_\_

Name and Title \_\_\_\_\_

Dated \_\_\_\_\_

**NON-COLLUSION DECLARATION**

The undersigned declares:

I am the \_\_\_\_\_ of \_\_\_\_\_, the party making the foregoing Bid.

The Bid is not made in the interest of, or on behalf of, any undisclosed person, partnership, company, association, organization, or corporation. The Bid is genuine and not collusive or sham. The Bidder has not directly or indirectly induced or solicited any other Bidder to put in a false or sham bid. The Bidder has not directly or indirectly colluded, conspired, connived, or agreed with any Bidder or anyone else to put in a sham bid, or to refrain from bidding. The Bidder has not in any manner, directly or indirectly, sought by agreement, communication, or conference with anyone to fix the Bid Price of the Bidder or any other Bidder, or to fix any overhead, profit, or cost element of the Bid Price, or of that of any other Bidder. All statements contained in the Bid are true. The Bidder has not, directly or indirectly, submitted his or her Bid Price or any breakdown thereof, or the contents thereof, or divulged information or data relative thereto, to any corporation, partnership, company, association, organization, bid depository, or to any member or agent thereof to effectuate a collusive or sham bid, and has not paid, and will not pay, any person or entity for such purpose.

Any person executing this declaration on behalf of a Bidder that is a corporation, partnership, joint venture, limited liability company, limited liability partnership, or any other entity, hereby represents that he or she has full power to execute, and does execute, this declaration on behalf of the Bidder.

I declare under penalty of perjury under the laws of the State of California that the foregoing is true and correct and that this declaration is executed on \_\_\_\_\_ [date], at \_\_\_\_\_ [city], \_\_\_\_\_ [state].

Name of Bidder \_\_\_\_\_

Signature \_\_\_\_\_

Name and Title \_\_\_\_\_

Dated \_\_\_\_\_

**IRAN CONTRACTING ACT CERTIFICATION**

(Public Contract Code section 2200 et seq.)

As required by California Public Contract Code Section 2204, the Contractor certifies subject to penalty for perjury that the option checked below relating to the Contractor’s status in regard to the Iran Contracting Act of 2010 (Public Contract Code Section 2200 et seq.) is true and correct:

The Contractor is not:

- (1) identified on the current list of person and entities engaged in investment activities in Iran prepared by the California Department of General Services in accordance with subdivision (b) of Public Contract Code Section 2203; or
- (2) a financial instruction that extends, for 45 days or more, credit in the amount of \$20,000,000 or more to any other person or entity identified on the current list of persons and entities engaging in investment activities in Iran prepared by the California Department of General Services in accordance with subdivision (b) of Public Contract Code Section 2203, if that person or entity uses or will use the credit to provide goods or services in the energy sector in Iran.

The City has exempted the Contractor from the requirements of the Iran Contracting Act of 2010 after making a public finding that, absent the exemption, the City will be unable to obtain the goods and/or services to be provided pursuant to the Contract.

The amount of the Contract payable to the Contractor for the Project does not exceed \$1,000,000.

Signature: \_\_\_\_\_

Printed Name: \_\_\_\_\_

Title: \_\_\_\_\_

Firm Name: \_\_\_\_\_

Date: \_\_\_\_\_

Note: In accordance with Public Contract Code Section 2205, false certification of this form shall be reported to the California Attorney General and may result in civil penalties equal to the greater of \$250,000 or twice the Contract amount, termination of the Contract and/or ineligibility to bid on contracts for three years.

**PUBLIC WORKS CONTRACTOR REGISTRATION CERTIFICATION**

Pursuant to Labor Code sections 1725.5 and 1771.1, all contractors and subcontractors that wish to bid on, be listed in a bid proposal, or enter into a contract to perform public work must be registered with the Department of Industrial Relations. See <http://www.dir.ca.gov/Public-Works/PublicWorks.html> for additional information.

No bid will be accepted nor any contract entered into without proof of the contractor's and subcontractors' current registration with the Department of Industrial Relations to perform public work.

Bidder hereby certifies that it is aware of the registration requirements set forth in Labor Code sections 1725.5 and 1771.1 and is currently registered as a contractor with the Department of Industrial Relations.<sup>1</sup>

Name of Bidder: \_\_\_\_\_

DIR Registration Number: \_\_\_\_\_

DIR Registration Expiration: \_\_\_\_\_

Small Project Exemption: \_\_\_\_\_ Yes or \_\_\_\_\_ No

Unless Bidder is exempt pursuant to the small project exemption, Bidder further acknowledges:

1. Bidder shall maintain a current DIR registration for the duration of the project.
2. Bidder shall include the requirements of Labor Code sections 1725.5 and 1771.1 in its contract with subcontractors and ensure that all subcontractors are registered at the time of bid opening and maintain registration status for the duration of the project.
3. Failure to submit this form or comply with any of the above requirements may result in a finding that the bid is non-responsive.

Name of Bidder \_\_\_\_\_

Signature \_\_\_\_\_

Name and Title \_\_\_\_\_

Dated \_\_\_\_\_

<sup>1</sup> If the Project is exempt from the contractor registration requirements pursuant to the small project exemption under Labor Code Sections 1725.5 and 1771.1, please mark "Yes" in response to "Small Project Exemption."

**CONTRACTOR'S CERTIFICATE REGARDING WORKERS' COMPENSATION**

I am aware of the provisions of section 3700 of the Labor Code which require every employer to be insured against liability for workers' compensation or to undertake self-insurance in accordance with the provisions of that code, and I will comply with such provisions before commencing the performance of the work of this Contract.

Name of Bidder \_\_\_\_\_

Signature \_\_\_\_\_

Name and Title \_\_\_\_\_

Dated \_\_\_\_\_

**FLEET COMPLIANCE CERTIFICATION**

Bidder hereby acknowledges that they have reviewed the California Air Resources Board's policies, rules and regulations and are familiar with the requirements of Title 13, California Code of Regulations, Division 3, Chapter 9, effective on January 1, 2024 (the "Regulation"). Bidder hereby certifies, subject to penalty for perjury, that the option checked below relating to the Bidder's fleet, and/or that of their subcontractor(s) ("Fleet") is true and correct:

- The Fleet is subject to the requirements of the Regulation, and the appropriate Certificate(s) of Reported Compliance have been attached hereto.
- The Fleet is exempt from the Regulation under section 2449.1(f)(2), and a signed description of the subject vehicles, and reasoning for exemption has been attached hereto.
- Bidder and/or their subcontractor is unable to procure R99 or R100 renewable diesel fuel as defined in the Regulation pursuant to section 2449.1(f)(3). Bidder shall keep detailed records describing the normal refueling methods, their attempts to procure renewable diesel fuel and proof that shows they were not able to procure renewable diesel (i.e. third party correspondence or vendor bids).
- The Fleet is exempt from the requirements of the Regulation pursuant to section 2449(i)(4) because this Project has been deemed an Emergency, as defined under section 2449(c)(18). Bidder shall only operate the exempted vehicles in the emergency situation and records of the exempted vehicles must be maintained, pursuant to section 2449(i)(4).
- The Fleet does not fall under the Regulation or are otherwise exempted and a detailed reasoning is attached hereto.

Name of Bidder: \_\_\_\_\_

Signature: \_\_\_\_\_

Name: \_\_\_\_\_

Title: \_\_\_\_\_

Date: \_\_\_\_\_

## CONTRACT FOR CONSTRUCTION

This Contract for Construction ("Contract"), No. **7031, 85003, & 86004** is made and entered into this \_\_\_\_\_ day of \_\_\_\_\_, 20\_\_ by and between the CITY OF UPLAND, with its principal place of business at 460 N. Euclid Avenue, Upland, California 91786 sometimes hereinafter called the "City" and \_\_\_\_\_, sometimes hereinafter called "Contractor."

**WITNESSETH:** That the parties hereto have mutually covenanted and agreed, and by these presents do covenant and agree with each other as follows:

### ARTICLE 1. SCOPE OF WORK.

The Contractor shall perform all Work within the time stipulated in the Contract, and shall provide all labor, materials, equipment, tools, utility services, and transportation to complete all of the Work required in strict compliance with the Contract Documents as specified in Article 5, below, for the following Project:

**PROJECT Nos. 7031, 85003 & 86004**

**BID No. 2024-05**

**11th Street Flashing Signal Beacon & Alley Improvements**

Contractor is an independent contractor and not an agent of the City. The Contractor and its surety shall be liable to the City for any damages arising as a result of the Contractor's failure to comply with this obligation.

### ARTICLE 2. TIME FOR COMPLETION.

Time is of the essence in the performance of the Work. The Work shall be commenced on the date stated in the City's Notice to Proceed. The Contractor shall complete all Work required by the Contract Documents within **45 calendar days** from the commencement date stated in the Notice to Proceed. By its signature hereunder, Contractor agrees the time for completion set forth above is adequate and reasonable to complete the Work.

### ARTICLE 3. CONTRACT PRICE.

The City shall pay to the Contractor as full compensation for the performance of the Contract, subject to any additions or deductions as provided in the Contract Documents, and including all applicable taxes and costs, the sum of <INSERT DOLLAR AMOUNT IN WORDS> Dollars (\$ \_\_\_\_\_). Payment shall be made as set forth in the General Conditions. The City will pay to Contractor compensation based upon the prices set forth in the Bid Schedule.

### ARTICLE 4. LIQUIDATED DAMAGES.

Contractor acknowledges that the City will sustain actual damages for each and every Day completion of the Project is delayed beyond the Contract Time. Because of the nature of the Project, it would be impracticable or extremely difficult to determine the City's actual damages. Accordingly, in accordance with Government Code section 53069.85, it is agreed that the Contractor will pay the City the sum of **\$250** for each and every calendar day of delay beyond the

time prescribed in the Contract Documents for finishing the Work, as Liquidated Damages and not as a penalty or forfeiture. In the event this is not paid, the Contractor agrees the City may deduct that amount from any money due or that may become due the Contractor under the Contract. This Section does not exclude recovery of other damages specified in the Contract Documents. Liquidated damages may be deducted from progress payments due Contractor, Project retention or may be collected directly from Contractor, or from Contractor's surety. These provisions for liquidated damages shall not prevent the City, in case of Contractor's default, from terminating the Contractor.

Consistent with Public Contract Code Section 7102, Contractor will be compensated for damages incurred due to delays for which the City is responsible. The parties agree that determining Contractor's exact delay damages is and will continue to be impracticable and extremely difficult. As such, for each calendar day in excess of the Contract Time, the City shall pay to the Contractor **\$250** per day as Reverse Liquidated Damages and not as a penalty or forfeiture. Such amount shall constitute the only payment allowed for any City caused delays and shall necessarily include all overhead, all profits, all administrative costs, all bond costs, all labor, materials, equipment and rental costs and any other costs, expenses and fees incurred or sustained as a result of such delays. Notice of requests for delay damages and additional days shall be provided to the City within five (5) Days from the discovery of the circumstances giving rise to any delay or three (3) Days from the discovery of any latent or subsurface conditions giving rise to a delay.

#### **ARTICLE 5. COMPONENT PARTS OF THE CONTRACT.**

The "Contract Documents" include the following:

- Notice Inviting Bids
- Instructions to Bidders
- Bid Forms
- Bid Acknowledgement
- Bid Schedule
- Bid Guarantee
- Designation of Subcontractors
- Information Required of Bidders
- Non-Collusion Declaration Form
- Iran Contracting Act Certification
- Public Works Contractor DIR Registration Certification
- Performance Bond
- Payment (Labor and Materials) Bond
- Contract for Construction
- General Conditions
- Special Conditions
- Specifications
- Addenda
- Construction Plans and Drawing
- Std. Specifications for Public Works Const. "Greenbook", 2018 edition
- Applicable Local Agency Standards and Specifications, as last revised
- Reference Specifications
- Approved and fully executed Change Orders
- Permits
- Any other documents contained in or incorporated into the Contract

The Contractor shall complete the Work in strict accordance with all of the Contract Documents.

All of the Contract Documents are intended to be complementary. Work required by one of the Contract Documents and not by others shall be done as if required by all. In the event of conflict, the various Contract Documents will be given effect in the order set forth in the General Conditions. This Contract shall supersede any prior agreement of the parties.

**ARTICLE 6. PROVISIONS REQUIRED BY LAW AND CONTRACTOR COMPLIANCE.**

Each and every provision of law required to be included in these Contract Documents shall be deemed to be included in these Contract Documents. The Contractor shall comply with all requirements of applicable federal, state and local laws, rules and regulations, including, but not limited to, the provisions of the California Labor Code and California Public Contract Code which are applicable to this Work.

**ARTICLE 7. INDEMNIFICATION.**

Contractor shall provide indemnification and defense as set forth in the General Conditions.

**ARTICLE 8. PREVAILING WAGES.**

Contractor shall be required to pay the prevailing rate of wages in accordance with the Labor Code which such rates shall be made available at the City's Office or may be obtained online at <http://www.dir.ca.gov> and which must be posted at the job site.

**ARTICLE 9. FALSE CLAIMS.**

Contractor acknowledges that if a false claim is submitted to the City, it may be considered fraud and Contractor may be subject to criminal prosecution. Contractor acknowledges that the False Claims Act, California Government Code sections 12650, et seq., provides for civil penalties where a person knowingly submits a false claim to a public entity. These provisions include within their scope false claims made with deliberate ignorance of the false information or in reckless disregard of the truth or falsity of the information. In the event the City seeks to recover penalties pursuant to the False Claims Act, it is entitled to recover its litigation costs, including attorneys' fees. Contractor hereby acknowledges that the filing of a false claim may the Contractor to an administrative debarment proceeding wherein Contractor may be prevented from further bidding on public contracts for a period of up to five (5) years.

**[REMAINDER OF PAGE LEFT INTENTIONALLY BLANK]**

IN WITNESS WHEREOF, this Contract has been duly executed by the above-named parties, on the day and year above written.

CITY OF UPLAND

\_\_\_\_\_  
**NAME OF CONTRACTOR**

[IF CORPORATION, TWO SIGNATURES, PRESENT **OR** VICE PRESIDENT **AND** SECRETARY **OR** TREASURER **REQUIRED**]

By: \_\_\_\_\_  
**Bill Velto, Mayor**

By: \_\_\_\_\_

ATTEST:

Its: \_\_\_\_\_

By: \_\_\_\_\_  
**Keri Johnson, City Clerk**

Printed Name: \_\_\_\_\_

APPROVED AS TO FORM:

[SECOND SIGNATURE LINE IF APPLICABLE]

By: \_\_\_\_\_  
**Best Best & Krieger LLP**  
**City Attorney**

By: \_\_\_\_\_

Its: \_\_\_\_\_

Printed Name: \_\_\_\_\_

\_\_\_\_\_  
Contractor's License Number and Classification

\_\_\_\_\_  
DIR Registration Number

**(CONTRACTOR'S SIGNATURE MUST BE NOTARIZED AND CORPORATE SEAL AFFIXED, IF APPLICABLE)**

**END OF CONTRACT**



# CALIFORNIA LEVINE ACT DISCLOSURE STATEMENT

California Government Code Section 84308, commonly referred to as the "Levine Act," prohibits City Officers from participating in any action concerning a license, permit, other entitlement for use, franchise, or contract (collectively "license, permit, or contract") if they receive political contribution(s) from a party, or its agent(s), totaling more than \$250 within the twelve (12) months before the proceeding, while a proceeding is pending, and for twelve (12) months following the date of a final decision in a proceeding.

The Levine Act also requires a member of the Upland City Council who has received such a contribution to disclose the contribution on the record of the proceeding and recuse themselves before the proceeding unless the violation has been properly cured.

Current Upland City Council Members are listed at:

<https://www.uplandca.gov/city-council-treasurer>

**Parties and their Agents are responsible for accessing the link to review the names and disclosing their applicable contributions to City Officers on the record of a proceeding.**

As a party to a proceeding, you are also required to provide information below about contributions made by you, your agents on behalf of you or your organization, your organization subject to the proceeding with the City, and any organization you direct or control pursuant to the aggregation rules at FPPC Reg. § 18438.5, except for uncompensated officers of a nonprofit organization. This form is to be submitted to the City of Upland and is a public record. If you have any questions about this form, please contact your City representative for assistance.

1. Have you or your company, or any agent/board member on behalf of you or your company/entity, made any political contributions of more than \$250 to any Upland City Council Member in the 12 months preceding the date of the submission of your proposal or application, or the anticipated date of any Council action?

YES If yes, please identify the Council Member(s): \_\_\_\_\_

NO

2. Do you or your company/entity, or any agency on behalf of you or your company/entity, anticipate or plan to make any political contribution of more than \$250 to any Upland City Council Member in the 12 months following any Council action related to your proposal or application?

YES If yes, please identify the Council Member(s): \_\_\_\_\_

NO

Answering yes to either of the two questions above does not preclude the Upland City Council from awarding a contract or approving an application or any subsequent action. It does, however, preclude the identified Council Member(s) from participating in any actions related to your proposal or application.

\_\_\_\_\_  
Date

\_\_\_\_\_  
Signature of authorized individual

\_\_\_\_\_  
Company/Applicant Name

(Levine Act definitions on reverse side)

## LEVINE ACT DISCLOSURE STATEMENT DEFINITIONS

Term	Definition	Law
<b>Covered "proceedings"</b>	A proceeding to grant, deny, revoke, restrict, or modify a license, permit or other entitlement for use, that does not solely involve purely ministerial decisions and is: (1) Applied for by the party; (2) Formally or informally requested by the party; or (3) A contract between the agency and the party or a franchisee granted by the agency to the party, other than a contract that is <b>competitively bid</b> , a <b>labor contract</b> , or a <b>personal employment contract</b> .	<a href="#">FPPC Reg 18438.2(a)</a>
<b>Party</b>	Any person who files an application for, or is the subject of, a proceeding involving a license, permit, or other entitlement for use.	<a href="#">Gov. Code 84308(a)(1)</a>
<b>Participant</b>	Any person who is not a party but who actively supports or opposes a particular decision in a proceeding involving a license, permit, or other entitlement for use and who has a financial interest in the decision. A person actively supports or opposes a particular decision in a proceeding if that person lobbies in person the officers or employees of the agency, testifies in person before the agency, or otherwise acts to influence officers of the agency.	<a href="#">Gov. Code 84308(a)(2)</a> <a href="#">FPPC Reg 18438.4</a>
<b>Agent</b>	A person who represents a party or participant for compensation and appears before or otherwise communicates with the governmental agency for the purpose of influencing the pending proceeding. See FPPC Reg 18438.3 for exceptions for certain consultants.	<a href="#">FPPC Reg 18438.3</a>
<b>Competitively Bid</b>	A contract required by law to be awarded to the lowest responsible bidder with a responsive bid, or, if the successful bidder refuses or fails to execute the contract, to the next lowest bidder with a responsive bid.	<a href="#">FPPC Reg 18438.2(a)(3)(A)</a>
<b>Labor Contract</b>	A contract or agreement reached through collective bargaining or with a representative group regarding the salary, benefits, or terms and conditions under an employment or retirement policy for employees or retirees, including a project labor agreement entered under Public Contract Code Section 2500.	<a href="#">FPPC Reg 18438.2(a)(3)(B)</a>
<b>Personal Employment Contract</b>	A contract for employment, including the terms and conditions of employment, between the agency and an agency employee. A contract with an independent contractor is NOT a personal employment contract.	<a href="#">FPPC Reg 18438.2(a)(3)(C)-(D)</a>

# Notary Acknowledgment

A notary public or other officer completing this certificate verifies only the identity of the individual who signed the document to which this certificate is attached, and not the truthfulness, accuracy, or validity of that document.

STATE OF CALIFORNIA  
 COUNTY OF \_\_\_\_\_

On \_\_\_\_\_, 20\_\_\_\_, before me, \_\_\_\_\_, Notary Public, personally appeared \_\_\_\_\_, who proved to me on the basis of satisfactory

evidence to be the person(s) whose name(s) is/are subscribed to the within instrument and acknowledged to me that he/she/they executed the same in his/her/their authorized capacity(ies), and that by his/her/their signature(s) on the instrument the person(s), or the entity upon behalf of which the person(s) acted, executed the instrument.

I certify under PENALTY OF PERJURY under the laws of the State of California that the foregoing paragraph is true and correct.

WITNESS my hand and official seal.

\_\_\_\_\_  
 Signature of Notary Public

### OPTIONAL

*Though the information below is not required by law, it may prove valuable to persons relying on the document and could prevent fraudulent removal and reattachment of this form to another document.*

#### CAPACITY CLAIMED BY SIGNER

- Individual
- Corporate Officer

\_\_\_\_\_ Title(s)

- Partner(s)                       Limited
- General

- Attorney-In-Fact
- Trustee(s)
- Guardian/Conservator
- Other:

Signer is representing:  
 Name Of Person(s) Or Entity(ies)

\_\_\_\_\_  
 \_\_\_\_\_

#### DESCRIPTION OF ATTACHED DOCUMENT

\_\_\_\_\_ Title or Type of Document

\_\_\_\_\_ Number of Pages

\_\_\_\_\_ Date of Document

\_\_\_\_\_ Signer(s) Other Than Named Above

### BOND FORMS

#### Performance Bond

KNOW ALL PERSONS BY THESE PRESENTS:

THAT WHEREAS, the CITY OF UPLAND , with its principal place of business at 460 N. Euclid Avenue, Upland, California 91786 (hereinafter referred to as the "City") has awarded to \_\_\_\_\_, (hereinafter referred to as the "Contractor") an agreement for **Contract No. 7031, 85003, & 86004 11th Street Flashing Signal Beacon & Alley Improvements**, (hereinafter referred to as the "Project").

WHEREAS, the work to be performed by the Contractor is more particularly set forth in the Contract Documents for the Project dated \_\_\_\_\_, (hereinafter referred to as "Contract Documents"), the terms and conditions of which are expressly incorporated herein by reference; and

WHEREAS, the Contractor is required by said Contract Documents to perform the terms thereof and to furnish a bond for the faithful performance of said Contract Documents.

NOW, THEREFORE, we, \_\_\_\_\_, the undersigned Contractor and \_\_\_\_\_ as Surety, a corporation organized and duly authorized to transact business under the laws of the State of California, are held and firmly bound unto the City in the sum of \_\_\_\_\_ DOLLARS, (\$\_\_\_\_\_), said sum being not less than one hundred percent (100%) of the total amount of the Contract, for which amount well and truly to be made, we bind ourselves, our heirs, executors and administrators, successors and assigns, jointly and severally, firmly by these presents.

THE CONDITION OF THIS OBLIGATION IS SUCH, that, if the Contractor, his or its heirs, executors, administrators, successors or assigns, shall in all things stand to and abide by, and well and truly keep and perform the covenants, conditions and agreements in the Contract Documents and any alteration thereof made as therein provided, on its part, to be kept and performed at the time and in the manner therein specified, and in all respects according to their intent and meaning; and shall faithfully fulfill all obligations including the one (1) year guarantee of all materials and workmanship; and shall indemnify and save harmless the City, its officials, officers, employees, and authorized volunteers, as stipulated in said Contract Documents, then this obligation shall become null and void; otherwise it shall be and remain in full force and effect.

As a part of the obligation secured hereby and in addition to the face amount specified therefore, there shall be included costs and reasonable expenses and fees including reasonable attorney's fees, incurred by the City in enforcing such obligation.

As a condition precedent to the satisfactory completion of the Contract Documents, unless otherwise provided for in the Contract Documents, the above obligation shall hold good for a period of one (1) year after the acceptance of the work by the City, during which time if Contractor shall fail to make full, complete, and satisfactory repair and replacements and totally protect the City from loss or damage resulting from or caused by defective materials or faulty workmanship. The obligations of Surety hereunder shall continue so long as any obligation of Contractor remains. Nothing herein shall limit the City's rights or the Contractor or Surety's obligations under the Contract, law or equity, including, but not limited to, California Code of Civil Procedure Section 337.15.

Whenever Contractor shall be, and is declared by the City to be, in default under the Contract Documents, the Surety shall remedy the default pursuant to the Contract Documents, or shall promptly, at the City's option:

- i. Take over and complete the Project in accordance with all terms and conditions in the Contract Documents; or
- ii. Obtain a bid or bids for completing the Project in accordance with all terms and conditions in the Contract Documents and upon determination by Surety of the lowest responsive and responsible bidder, arrange for a Contract between such bidder, the Surety and the City, and make available as work progresses sufficient funds to pay the cost of completion of the Project, less the balance of the contract price, including other costs and damages for which Surety may be liable. The term "balance of the contract price" as used in this paragraph shall mean the total amount payable to Contractor by the City under the Contract and any modification thereto, less any amount previously paid by the City to the Contractor and any other set offs pursuant to the Contract Documents.
- iii. Permit the City to complete the Project in any manner consistent with California law and make available as work progresses sufficient funds to pay the cost of completion of the Project, less the balance of the contract price, including other costs and damages for which Surety may be liable. The term "balance of the contract price" as used in this paragraph shall mean the total amount payable to Contractor by the City under the Contract and any modification thereto, less any amount previously paid by the City to the Contractor and any other set offs pursuant to the Contract Documents.

Surety expressly agrees that the City may reject any contractor or subcontractor which may be proposed by Surety in fulfillment of its obligations in the event of default by the Contractor.

Surety shall not utilize Contractor in completing the Project nor shall Surety accept a bid from Contractor for completion of the Project if the City, when declaring the Contractor in default, notifies Surety of the City's objection to Contractor's further participation in the completion of the Project.

The Surety, for value received, hereby stipulates and agrees that no change, extension of time, alteration or addition to the terms of the Contract Documents or to the Project to be performed thereunder shall in any way affect its obligations on this bond, and it does hereby waive notice of any such change, extension of time, alteration or addition to the terms of the Contract Documents or to the Project.

**[REMAINDER OF PAGE LEFT INTENTIONALLY BLANK]**

IN WITNESS WHEREOF, we have hereunto set our hands and seals this \_\_\_\_\_ day of \_\_\_\_\_, 20\_\_.

(Corporate Seal)

\_\_\_\_\_  
Contractor/ Principal

By \_\_\_\_\_

Title \_\_\_\_\_

(Corporate Seal)

\_\_\_\_\_  
Surety

By \_\_\_\_\_  
Attorney-in-Fact

(Attach Attorney-in-Fact Certificate)

Title \_\_\_\_\_

The rate of premium on this bond is \_\_\_\_\_ per thousand. The total amount of premium charges is \$\_\_\_\_\_.  
(The above must be filled in by corporate attorney.)

**THIS IS A REQUIRED FORM**

Any claims under this bond may be addressed to:

(Name and Address of Surety)

\_\_\_\_\_  
\_\_\_\_\_  
\_\_\_\_\_

(Name and Address of Agent or Representative for service of process in California, if different from above)

\_\_\_\_\_  
\_\_\_\_\_  
\_\_\_\_\_

(Telephone number of Surety and Agent or Representative for service of process in California)

\_\_\_\_\_



# Notary Acknowledgment

A notary public or other officer completing this certificate verifies only the identity of the individual who signed the document to which this certificate is attached, and not the truthfulness, accuracy, or validity of that document.

STATE OF CALIFORNIA  
 COUNTY OF \_\_\_\_\_

On \_\_\_\_\_, 20\_\_\_\_, before me, \_\_\_\_\_, Notary Public, personally appeared \_\_\_\_\_, who proved to me on the basis of satisfactory

evidence to be the person(s) whose name(s) is/are subscribed to the within instrument and acknowledged to me that he/she/they executed the same in his/her/their authorized capacity(ies), and that by his/her/their signature(s) on the instrument the person(s), or the entity upon behalf of which the person(s) acted, executed the instrument.

I certify under PENALTY OF PERJURY under the laws of the State of California that the foregoing paragraph is true and correct.

WITNESS my hand and official seal.

\_\_\_\_\_  
 Signature of Notary Public

### OPTIONAL

*Though the information below is not required by law, it may prove valuable to persons relying on the document and could prevent fraudulent removal and reattachment of this form to another document.*

#### CAPACITY CLAIMED BY SIGNER

- Individual
- Corporate Officer

\_\_\_\_\_ Title(s)

- Partner(s)                       Limited
- General

- Attorney-In-Fact
- Trustee(s)
- Guardian/Conservator
- Other:

Signer is representing:  
 Name Of Person(s) Or Entity(ies)

\_\_\_\_\_  
 \_\_\_\_\_

#### DESCRIPTION OF ATTACHED DOCUMENT

\_\_\_\_\_ Title or Type of Document

\_\_\_\_\_ Number of Pages

\_\_\_\_\_ Date of Document

\_\_\_\_\_ Signer(s) Other Than Named Above

**NOTE:** This acknowledgment is to be completed for the Attorney-in-Fact. The Power-of Attorney to local representatives of the bonding company must also be attached.

**END OF PERFORMANCE BOND**

**Payment Bond (Labor and Materials).**

KNOW ALL MEN BY THESE PRESENTS That

WHEREAS, the CITY OF UPLAND , with its principal place of business at 460 N. Euclid Avenue, Upland, California 91786 (hereinafter designated as the "City"), by action taken or a resolution passed \_\_\_\_\_, 20\_\_\_\_, has awarded to \_\_\_\_\_ hereinafter designated as the "Principal," a contract for the work described as follows: **Contract No. 7031, 85003, & 86004 11th Street Flashing Beacon Signal & Alley Improvements.**(the "Project"); and

WHEREAS, the work to be performed by the Contractor is more particularly set forth in the Contract Documents for the Project dated \_\_\_\_\_, (hereinafter referred to as "Contract Documents"), the terms and conditions of which are expressly incorporated herein by reference; and

WHEREAS, said Principal is required to furnish a bond in connection with said contract; providing that if said Principal or any of its Subcontractors shall fail to pay for any materials, provisions, provender, equipment, or other supplies used in, upon, for or about the performance of the work contracted to be done, or for any work or labor done thereon of any kind, or for amounts due under the Unemployment Insurance Code or for any amounts required to be deducted, withheld, and paid over to the Employment Development Department from the wages of employees of said Principal and its Subcontractors with respect to such work or labor the Surety on this bond will pay for the same to the extent hereinafter set forth.

NOW THEREFORE, we, the Principal and \_\_\_\_\_ as Surety, are held and firmly bound unto the City in the penal sum of \_\_\_\_\_ Dollars (\$\_\_\_\_\_) lawful money of the United States of America, for the payment of which sum well and truly to be made, we bind ourselves, our heirs, executors, administrators, successors and assigns, jointly and severally, firmly by these presents.

THE CONDITION OF THIS OBLIGATION IS SUCH that if said Principal, his or its subcontractors, heirs, executors, administrators, successors or assigns, shall fail to pay any of the persons named in Civil Code Section 9100, fail to pay for any materials, provisions or other supplies, used in, upon, for or about the performance of the work contracted to be done, or for any work or labor thereon of any kind, or amounts due under the Unemployment Insurance Code with respect to work or labor performed under the contract, or for any amounts required to be deducted, withheld, and paid over to the Employment Development Department or Franchise Tax Board from the wages of employees of the contractor and his subcontractors pursuant to Revenue and Taxation Code Section 18663, with respect to such work and labor the Surety or Sureties will pay for the same, in an amount not exceeding the sum herein above specified, and also, in case suit is brought upon this bond, all litigation expenses incurred by the City in such suit, including reasonable attorneys' fees, court costs, expert witness fees and investigation expenses.

This bond shall inure to the benefit of any of the persons named in Civil Code Section 9100 so as to give a right of action to such persons or their assigns in any suit brought upon this bond.

It is further stipulated and agreed that the Surety on this bond shall not be exonerated or released from the obligation of this bond by any change, extension of time for performance, addition, alteration or modification in, to, or of any contract, plans, specifications, or agreement pertaining or relating to any scheme or work of improvement herein above described, or pertaining or relating to the furnishing of labor, materials, or equipment therefore, nor by any change or modification of any terms of payment or extension of the time for any payment pertaining or relating to any scheme or work of improvement herein above described, nor by any rescission or attempted rescission or attempted rescission of the contract, agreement or bond, nor by any conditions precedent or subsequent in the bond attempting to limit the right of recovery of claimants otherwise entitled to recover under any such contract or agreement or under the bond, nor by any fraud practiced by any person other than the claimant seeking to recover on the bond and that this bond be construed most strongly against the Surety and in favor of all persons for whose benefit such bond is given, and under no circumstances shall Surety be released from liability to those for whose benefit such bond has been given, by reason of any breach of contract between the owner or the City and original contractor or on the part of any obligee named in such bond, but the sole conditions of recovery shall be that claimant is a person described in Civil Code Section 9100, and has not been paid the full amount of his claim.

The Surety, for value received, hereby stipulates and agrees that no change, extension of time, alteration or addition to the terms of the Contract to be performed thereunder, shall in any way affect its obligations on this bond, and it does hereby waive notice of any such change, extension of time, alteration or addition to the terms of Contract, including but not limited to, the provisions of Sections 2819 and 2845 of the California Civil Code.

IN WITNESS WHEREOF, we have hereunto set our hands and seals this \_\_\_\_\_ day of \_\_\_\_\_, 20\_\_.

(Corporate Seal)

\_\_\_\_\_  
Contractor/ Principal

By \_\_\_\_\_

Title \_\_\_\_\_

(Corporate Seal)

\_\_\_\_\_  
Surety

By \_\_\_\_\_

Attorney-in-Fact

(Attach Attorney-in-Fact Certificate)

Title \_\_\_\_\_

## Notary Acknowledgment

A notary public or other officer completing this certificate verifies only the identity of the individual who signed the document to which this certificate is attached, and not the truthfulness, accuracy, or validity of that document.

STATE OF CALIFORNIA  
 COUNTY OF \_\_\_\_\_

On \_\_\_\_\_, 20\_\_\_\_, before me, \_\_\_\_\_, Notary Public, personally appeared \_\_\_\_\_, who proved to me on the basis of satisfactory

evidence to be the person(s) whose name(s) is/are subscribed to the within instrument and acknowledged to me that he/she/they executed the same in his/her/their authorized capacity(ies), and that by his/her/their signature(s) on the instrument the person(s), or the entity upon behalf of which the person(s) acted, executed the instrument.

I certify under PENALTY OF PERJURY under the laws of the State of California that the foregoing paragraph is true and correct.

WITNESS my hand and official seal.

\_\_\_\_\_  
 Signature of Notary Public

### OPTIONAL

*Though the information below is not required by law, it may prove valuable to persons relying on the document and could prevent fraudulent removal and reattachment of this form to another document.*

#### CAPACITY CLAIMED BY SIGNER

- Individual
- Corporate Officer

\_\_\_\_\_  
 Title(s)

- Partner(s)                       Limited
- General

- Attorney-In-Fact
- Trustee(s)
- Guardian/Conservator
- Other:

Signer is representing:  
 Name Of Person(s) Or Entity(ies)

\_\_\_\_\_  
 \_\_\_\_\_

#### DESCRIPTION OF ATTACHED DOCUMENT

\_\_\_\_\_  
 Title or Type of Document

\_\_\_\_\_  
 Number of Pages

\_\_\_\_\_  
 Date of Document

\_\_\_\_\_  
 Signer(s) Other Than Named Above

NOTE: This acknowledgment is to be completed for Contractor/Principal.

# Notary Acknowledgment

A notary public or other officer completing this certificate verifies only the identity of the individual who signed the document to which this certificate is attached, and not the truthfulness, accuracy, or validity of that document.

STATE OF CALIFORNIA  
 COUNTY OF \_\_\_\_\_

On \_\_\_\_\_, 20\_\_\_\_, before me, \_\_\_\_\_, Notary Public, personally appeared \_\_\_\_\_, who proved to me on the basis of satisfactory

evidence to be the person(s) whose name(s) is/are subscribed to the within instrument and acknowledged to me that he/she/they executed the same in his/her/their authorized capacity(ies), and that by his/her/their signature(s) on the instrument the person(s), or the entity upon behalf of which the person(s) acted, executed the instrument.

I certify under PENALTY OF PERJURY under the laws of the State of California that the foregoing paragraph is true and correct.

WITNESS my hand and official seal.

\_\_\_\_\_  
 Signature of Notary Public

### OPTIONAL

*Though the information below is not required by law, it may prove valuable to persons relying on the document and could prevent fraudulent removal and reattachment of this form to another document.*

#### CAPACITY CLAIMED BY SIGNER

- Individual
- Corporate Officer

\_\_\_\_\_ Title(s)

- Partner(s)                       Limited
- General

- Attorney-In-Fact
- Trustee(s)
- Guardian/Conservator
- Other:

Signer is representing:  
 Name Of Person(s) Or Entity(ies)

\_\_\_\_\_  
 \_\_\_\_\_

#### DESCRIPTION OF ATTACHED DOCUMENT

\_\_\_\_\_ Title or Type of Document

\_\_\_\_\_ Number of Pages

\_\_\_\_\_ Date of Document

\_\_\_\_\_ Signer(s) Other Than Named Above

**NOTE:** This acknowledgment is to be completed for the Attorney-in-Fact. The Power-of-Attorney to local representatives of the bonding company must also be attached.

**END OF PAYMENT BOND**

## GENERAL PROVISIONS

The Standard Specifications for the City of Upland shall be the latest edition of the **STANDARD SPECIFICATIONS FOR PUBLIC WORKS CONSTRUCTION (SSPWC), 2018 EDITION** (sometimes hereinafter referred to as the Greenbook), written and promulgated by the Southern California Chapter, American Public Works Association, and Southern California Districts Associated General Contractors of California Joint Cooperative Committee, including all published amendments thereto except for the following amendments, deletions and modifications.

Any conflict arising between these modifications and the Standard Specifications for Public Works Construction shall be resolved by the Engineer, whose decision shall be final.

### **Modifications to the Standard Specifications for Public Works Construction**

The following amendments, additions and deletions shall be incorporated into the Greenbook:

## **SECTION 1 TERMS, DEFINITIONS, ABBREVIATIONS AND SYMBOLS**

### **1-2 Definitions.**

Whenever used in the Contract Documents and printed with initial capital letters, the terms listed below will have the meanings indicated which are applicable to both the singular and plural thereof. In addition to terms specifically defined below, terms with initial capital letters in the Contract Documents include references to identified articles and paragraphs, and the titles of other documents or forms.

Act of God – An earthquake of magnitude of 3.5 or higher on the Richter scale or a tidal wave.

Additional Work – New or unforeseen work will be classified as “Additional Work” when the Engineer determines that it is not covered by the Contract.

Agency – The City of Upland.

Applicable Laws – The laws, statutes, ordinances, rules, codes, regulations, permits, and licenses of any kind, issued by local, state or federal governmental authorities or private authorities with jurisdiction (including utilities), to the extent they apply to the Work.

Bid – The offer or proposal of a Bidder submitted on the prescribed form setting forth the prices and other terms for the Work to be performed.

Bid Guarantee – The Bid Bond, cashier’s check, or certified check to be made by the Bidder, which is to accompany the Bid as a guaranty of good faith to enter into a written contract.

Board – The City Council of the City of Upland or the Board of Directors of Successor Agency to the Upland Community Redevelopment Agency.

Change Order (“CO”) – A document that authorizes an addition, deletion, or revision in the Work or an adjustment in the Contract Price or the Contract Times, issued on or after the

Effective Date of the Contract, in accordance with the Contract Documents and in the form contained in the Contract Documents.

Change Order Request (“COR”) – A request made by the Contractor for an adjustment in the Contract Price and/or Contract Times as the result of a Contractor-claimed change to the Work. This term may also be referred to as a Change Order Proposal (“COP”), or Request for Change (“RFC”).

City’s Representative – The City Engineer and/or his/her designee, and acting through properly authorized agents, such as the Engineer or such other agents acting within the scope of the particular duties entrusted to them. Also sometimes referred to as the “City’s Representative” or “Representative” in the Contract Documents. The terms the City and Owner may be used interchangeably.

Claim – A demand or assertion by the City or Contractor seeking an adjustment of Contract Price or Contract Times, or both, or other relief with respect to the terms of the Contract. A demand for money or services by a third party is not a Claim.

Clerk or City Clerk – The City Clerk of the City of Upland.

Contract – The entire integrated written agreement between the City and Contractor concerning the Work. “Contract” may be used interchangeably with “Agreement” in the Contract Documents. The Contract supersedes prior negotiations, representations, or agreements, whether written or oral, and includes all Contract Documents.

Contract Documents – The documents listed in Section 00 52 13, Article 5 of the Contract for Construction. Some documents provided by the City to the Bidders and Contractor, including but not limited to reports and drawings of subsurface and physical conditions are not Contract Documents.

Contract Price – Amount to be paid by the City to the Contractor as full compensation for the performance of the Contract and completion of the Work, subject to any additions or deductions as provided in the Contract Documents, and including all applicable taxes and costs.

Contract Time – The number of days or the dates stated in the Contract Documents to: achieve defined milestones, if any; and to complete the Work so that it is ready for final payment.

Contractor’s Designated On-Site Representative – The Contractor’s Designated On-Site Representative will be identified by the Contractor and shall not be changed without prior written consent of the City.

Critical Supply Shortage – An unusual shortage in materials that is (a) supported by documented proof that Contractor made every effort to obtain such materials from all available sources; (b) such shortage is due to the fact that such materials are not physically available from single or multiple sources or could have been obtained only at exorbitant prices entirely inconsistent with current and standard rates taking into account the quantities involved and the usual industry practices in obtaining such quantities; and (c) such shortages and the difficulties in obtaining alternate sources of materials could not have been known or anticipated by Contractor at the time it submitted its bid or entered

the Contract. Market fluctuations in prices of materials, whether or not resulting from a Force Majeure Event, does not constitute a Critical Supply Shortage.

Day – A calendar day of 24 hours measured from midnight to the next midnight.

Daily Rate – The Daily Rate stipulated in the Contract Documents as full compensation to the Contractor due to the City’s unreasonable delay to the Project that was not contemplated by the parties.

Defective Work – Work that is unsatisfactory, faulty, or deficient; or that does not conform to the Contract Documents; or that does not meet the requirements of any inspection, reference standard, test, or approval referenced in the Contract Documents.

Demobilization – The complete dismantling and removal by the Contractor of all of the Contractor’s temporary facilities, equipment, and personnel at the Site.

Drawings – That part of the Contract Documents prepared by of the Engineer of Record which graphically shows the scope, extent, and character of the Work to be performed by Contractor. Shop Drawings and other Contractor Submittals are not Drawings as so defined.

Effective Date of the Contract – The date indicated in the Contract on which it becomes effective, but if no such date is indicated, it means the date on which the Contract is signed and delivered by the last of the two parties to sign and deliver.

Engineer – Whenever not qualified, shall mean the City Engineer or the Engineer authorized to act for and in behalf of the City, acting either directly or through properly authorized agents, such agents acting severally within the scope of the particular duties entrusted to them.

Force Majeure Event – An event that materially affects a party’s performance and is one or more of the following: (1) Acts of God or other natural disasters occurring at the Site; (2) terrorism or other acts of a public enemy; (3) orders of governmental authorities (including, without limitation, unreasonable and unforeseeable delay in the issuance of permits or approvals by governmental authorities that are required for the Work); (4) pandemics, epidemics or quarantine restrictions; (5) strikes and other organized labor action occurring at the Site and the effects thereof on the Work, only to the extent such strikes and other organized labor action are beyond the control of Contractor and its Subcontractors, of every Tier, and to the extent the effects thereof cannot be avoided by use of replacement workers; and (6) a Critical Supply Shortage. For purposes of this section, “orders of governmental authorities,” includes ordinances, emergency proclamations and orders, rules to protect the public health, welfare and safety, and other actions of the City in its capacity as a municipal authority.

Hazardous Waste – The term “Hazardous Waste” shall have the meaning provided in Section 104 of the Solid Waste Disposal Act (42 U.S.C. § 6903) as amended from time to time, or any substance or material identified as hazardous under any state or federal statute governing handling, disposal and/or cleanup of any such substance or material, whichever is more restrictive.

Holiday – Holidays occur on:

New Year's Day - January 1

Martin Luther King, Jr. Day – Third Monday in January

President's Day – Third Monday in February

Memorial Day - Last Monday in May

Independence Day - July 4

Labor Day - First Monday in September

Thanksgiving Day - Fourth Thursday in November

Friday after Thanksgiving

Christmas Eve – December 24

Christmas Day - December 25

New Year's Eve – December 31

If any Holiday listed above falls on a Saturday, Saturday and the preceding Friday are both Holidays. If the Holiday should fall on a Sunday, Sunday and the following Monday are both Holidays.

Laboratory – The official testing laboratory of the Agency or other laboratories designated, in writing, by the Engineer.

Notice of Award – The written notice by the City to the Successful Bidder stating that upon timely compliance by the Successful Bidder with the conditions precedent listed therein, the City will sign and deliver the Contract.

Notice of Completion – The form which may be executed by the City constituting final acceptance of the Project.

Notice to Proceed -- A written notice given by the City to Contractor fixing the date on which the Contractor may proceed with the Work and when Contract Times will commence to run.

Project -- The total construction of which the Work to be performed under the Contract Documents may be the whole, or a part.

Record Drawings – The record set of as-builts prepared by the Contractor during the Work in accordance with the requirements of the General Conditions.

Recyclable Waste Materials – Materials removed from the Site which are required to be diverted to a recycling center rather than an area landfill. Recyclable Waste Materials include, but are not limited to, asphalt, concrete, brick, concrete block, and rock.

Sample – A physical example furnished by the Contractor to illustrate materials, equipment or workmanship; to establish standards by which the Work will be judged.

Schedule of Submittals – A schedule, prepared and maintained by Contractor, of required submittals and the time requirements to facilitate scheduled performance of related construction activities.

Shop Drawings – All drawings, diagrams, illustrations, schedules, and other data or information which are specifically prepared or assembled by or for Contractor and submitted by Contractor to illustrate some portion of the Work.

Site – Lands or areas indicated in the Contract Documents as being furnished by the City upon which the Work is to be performed, including rights-of-way and easements for access thereto, and such other lands furnished by the City which are designated for the use of Contractor.

Specifications – That part of the Contract Documents consisting of written requirements for materials, equipment, systems, standards and workmanship as applied to the Work, and certain administrative requirements and procedural matters applicable thereto. This includes, but not limited to, the Standard Specifications, Reference Specifications, Special Specifications, and specifications in Change Orders or Supplemental Agreements between the Contractor and the Board.

Stop Payment Notice – A written notice as defined in Civil Code section 8044.

Submittal – Written and graphic information and physical samples prepared and supplied by the Contractor demonstrating various portions of the Work.

Successful Bidder – The responsible Bidder submitting a responsive Bid to whom the City makes an award.

Supplier – A manufacturer, fabricator, supplier, distributor, material man, or vendor having a direct contract with Contractor or with any Subcontractor to furnish materials or equipment used in the performance of the Work or to be incorporated in the Work.

Underground Facilities – All underground pipelines, conduits, ducts, cables, wires, manholes, vaults, tanks, tunnels, or other such facilities or attachments, and any encasements containing such facilities, including those that convey electricity, gases, steam, liquid petroleum products, telephone or other communications, cable television, water, wastewater, storm water, other liquids or chemicals, or traffic or other control systems.

Unit Price Work – Work to be paid for on the basis of unit prices as provided by the Contractor in its Bid or as adjusted in accordance with the Contract Documents.

Warranty – A guarantee provided to the City by the Contractor that the Work will remain free of defects and suitable for its intended use for the period required by the Contract Documents or the longest period permitted by the law of this state, whichever is longer.

Work – The entire construction or the various separately identifiable parts thereof required to be provided under the Contract Documents. Work includes and is the result of

performing or providing all labor, services, and documentation necessary to produce such construction, and furnishing, installing, and incorporating all materials and equipment into such construction, all as required by the Contract Documents.

### **1-2.1 Terminology**

A new **Section 1-2.1** hereby is **added** to Section 1 of the Greenbook, as follows:

B. The words and terms below are not defined but, when used in the Contract Documents, have the indicated meaning.

1. The word “furnish,” when used in connection with services, materials, or equipment, shall mean to supply and deliver said services, materials, or equipment to the Site (or some other specified location) ready for use or installation and in usable or operable condition.
2. The word “install,” when used in connection with services, materials, or equipment, shall mean to put into use or place in final position said services, materials, or equipment complete and ready for intended use.
3. The words “perform” or “provide,” when used in connection with services, materials, or equipment, shall mean to furnish and install said services, materials, or equipment complete and ready for intended use.
4. Regardless of whether “furnish,” “install,” “perform,” or “provide” is used in connection with services, materials, or equipment, an obligation of Contractor is implied.

C. Unless stated otherwise in the Contract Documents, words or phrases that have a well-known technical or construction industry or trade meaning are used in the Contract Documents in accordance with such recognized meaning.

### **1-3.3 Institutions**

**Section 1-3.3** of the Greenbook shall be **amended** to include the following:

A.P.W.A. – The latest American Public Works Association

A.W.W.A. – The latest American Water Works Association

A.S.C.E. – The latest American Society of Civil Engineers

A.S.M.E. – The latest American Society of Mechanical Engineers

AQMD – South Coast Air Quality Management District

## **1-6 Bidding and Submission of the Bid**

The following subsections shall be added to Section 1-6 of the Greenbook,

- 1-6.3 Availability of Plans and Specifications.** Plans and specifications may be examined at the Office of the Engineering Manager located at 1370 North Benson Avenue, Upland, CA 91786. Copies of the plans and specifications, the and proposal forms are available for purchase at the Office of the Engineering Manager.
- 1-6.4 Approximate Estimate.** The quantities given in the Notice to Bidders, proposal and contract forms are approximate only, being given as a basis for the comparison of bids, and the Agency does not, expressly or by implication, agree that the actual amount of work will correspond therewith. For work bid on a lump sum price basis, any estimate of quantities is provided for the convenience of Bidders and for comparison of bids and is not guaranteed to be correct by the Agency to be the entire amount.
- 1-6.5 Examination of Plans, Specifications and Site of the Work.** Prior to the submittal of a bid response, the Bidder shall examine the Site of the Work along with reviewing the Specifications, Plans, Notice Inviting Bids, Project Proposal, General Provisions, Special Provisions, and the Contract/Agreement.
- 1-6.6 Proposal Form.** All proposals must be submitted on forms for that purpose furnished by the Agency. Letters of transmittal will be considered a non-responsive bid. All proposals shall give the prices proposed, both in writing and figures, and shall be signed by the Bidder, who must give his address. The Bidder shall fill out all blanks in the proposal form as therein required. In case of error, unit prices will govern over extensions, and written words will govern over numerals, unless it can be established that an obviously incorrect entry has been made.
- No contractor or subcontractor may be listed on a bid proposal for a public works project (submitted on or after March 1, 2015) unless registered with the Department of Industrial Relations pursuant to Labor Code section 1725.5 [with limited exceptions from this requirement for bid purposes only under Labor Code section 1771.1(a)].**
- 1-6.7 Rejection of Proposals Containing Alterations or Irregularities.** Proposals may be rejected if they show any alterations of form, additions not called for, conditional bids, incomplete bids, or irregularities of any kind. When proposals are signed by an agent, other than an officer or manager of a corporation or a member of a partnership, a power of attorney or written authorization must be on file with the Agency prior to opening bids or shall be submitted with the proposal; otherwise, the proposal will be rejected as irregular and unauthorized.
- 1-6.8 Proposal Guaranty.** All bids shall be presented in a sealed envelope and shall be accompanied by "Proposal Guaranty" made payable to the Agency and for an amount equal to at least ten percent (10%) of the bid unless otherwise specified on the "Notice Inviting Sealed Bids or Proposals." Said guaranty shall be cash, an unconditional certified or cashier's check, a bank or postal money order, or bid bond executed as surety by a corporation authorized to issue surety bonds in the State of California.

- 1-6.9 Withdrawal of Proposals.** Any bid may be withdrawn at any time prior to, but not after, the hour fixed in the public notice for the opening of bids, provided that a request in writing executed by the Bidder or his duly authorized representative, for the withdrawal of such bid is filed with the Clerk. The withdrawal of a bid shall not prejudice the right of a Bidder to file a new bid.
- 1-6.10 Disqualification of Bidders.** More than one proposal from an individual, a firm or partnership, a Corporation or an association under the same or different names will not be considered. Reasonable grounds for believing that any bidder is interested in more than one proposal for the work contemplated will cause the rejection of all proposals in which such Bidder is interested. If there is reason for believing that collusion exists among the bidders, none of the participants in such collusion will be considered in this or future proposals. Proposals in which the prices are unbalanced may be rejected.
- 1-6.11 Competency of Bidders.** Prior to the submission of bids, the Contractor shall be licensed in accordance with the provisions of Chapter 9 of Division III of the Business and Professional Code of the State of California and evidence of such license shall be presented to the Engineer on request. The Engineer may require the Bidder to present satisfactory evidence that he has sufficient experience and that he is fully prepared with the necessary capital, materials, machinery and skilled workmen to carry out the contract.
- 1-6.12 Material Guaranty.** Before any contract is awarded, Bidders may be required to furnish a complete statement of the origin, composition and manufacture of any or all materials to be used in the construction of the work, together with samples, which samples may be subjected to the tests provided for in these specifications to determine their quality and fitness for the work.
- 1-6.13 Progress Schedule.** The successful bidder shall submit a progress schedule showing thereon the time he proposes to occupy in prosecuting the various major divisions of the work and his proposed sequence of operations.

## **1-7 Award and Execution of the Contract**

**Section 1-7** of the *Greenbook* hereby is amended to read as follows:

- 1-7.1 Consideration of Bids.** Bids will be opened publicly by the Purchasing Coordinator or a designated representative on the date and at the time set forth in the "Notice Inviting Sealed Bids or Proposals." The right is reserved by the Agency by action of the Board to reject any or all bids, to advertise for new proposals, to negotiate in the open market for a contract at a reasonable price, to purchase in the open market, or to have the work performed by Agency employees, or to abandon the work if, in the judgment of the Board, the best interest of the Agency will be promoted thereby.

In all other respects, the remainder of this section shall remain unchanged.

- 1-7.2 Contract Bonds.** Section 1-7.2 of the *Greenbook* shall be **amended** to include the following:

Contractor shall submit the bonds on the forms provided with the Contract Documents, duly executed by a responsible corporate surety admitted to transact surety business in the State of California, as defined in Code of Civil Procedure section 995.120, and listed in the United States Department of the Treasury circular entitled "Companies Holding Certificates of Authority as Acceptable Sureties on Federal Bonds and as Acceptable Reinsuring Companies," authorized to do business in the State of California and acceptable to the City conditioned upon the faithful performance by the Contractor of all requirements of the Contract Documents. Each of the bonds shall be in a sum no less than one hundred percent (100%) of the Contract Price. Bonds shall be delivered to the City within ten (10) Days after receipt of the Notice of Award and before execution of the Contract by the City.

- 1-7.3 Award of Contract.** The award of the contract, if it be awarded, will be to the lowest responsible Bidder whose proposal complies with all the requirements prescribed. The award, if made, will be made within **ninety (90) calendar days** after the opening of the proposals.

**No contractor or subcontractor may be awarded a contract for public work on a public works project (awarded on or after April 1, 2015) unless registered with the Department of Industrial Relations pursuant to Labor Code section 1725.5.**

All bids will be compared on the basis of the Agency's estimate of the quantities of work to be done.

- 1-7.4 Return of Proposal Guarantees.** All proposal guarantees will be held by the Agency until the contract has been signed, after which they will be returned to the respective bidders whose proposals they accompany. If bids are rejected, the proposal guarantees will be returned after the date of the rejection.

- 1-7.5 Execution of Contract.** Before the City will execute the Contract, the Contractor shall furnish and file with the City a signed Contract and the necessary Performance Bond, Payment Bond, and Certificates of Insurance and Endorsements, as well as any other documents specified in the Contract Documents, within ten (10) calendar days after receipt of the Notice of Award, unless otherwise specified by the City. Upon receipt of the required Contract Documents, the City will execute the Contract, establishing the Effective Date of the Contract.

- 1-7.6 Evidence of Insurance.** Prior to commencing any Work but no later than ten (10) Days after receipt of the Notice of Award, the Contractor shall submit or cause to be submitted any and all Certificates of Insurance and Endorsements, showing that the Contractor has the required insurance, to the attention of the City. Such insurance is to be provided at the sole cost and expense of the Contractor. No Work shall be performed until all of the required insurance has been received and approved.

- 1-7.7 Contractor's Failure to Perform.** Should Contractor fail to comply with timelines provided above, the City shall retain the right to enforce and collect on the

Contractor's Bid Guarantee, rescind award to the Contractor and award the Contract to the next lowest responsive, responsible bidder as determined by the City. If the City elects to accept bonds and insurance submitted late, the Contract Times will begin to run as of the date stated in the Notice to Proceed. However, the number of days beyond the original ten (10) Days it took to receive the properly executed Contract and related items may be deducted from the Contract Times.

- 1-7.8 Commencement of Contract Times; Notice to Proceed.** The City will not issue a Notice to Proceed until after the Effective Date of the Contract. Work shall commence within ten (10) Days of the date stated in the Notice to Proceed. The Contract Times begin to run on the date specified in the Notice to Proceed. No Work shall be done at the Site prior to the issuance of the Notice to Proceed.

## **SECTION 2 SCOPE OF THE WORK**

### **2-4 Cooperation and Collateral Work.**

**Section 2-4** of the Greenbook shall be **amended** to include the following:

- A. The City reserves the right to let other contracts in connection with this Work or on the Project site. Contractor shall permit other contractors reasonable access and storage of their materials and execution of their work and shall properly connect and coordinate its Work with theirs. To ensure proper execution of its subsequent Work, Contractor shall immediately inspect work already in place and shall at once report to the Engineer any problems with the Work in place or discrepancies with the Contract Documents.
- B. Contractor shall ascertain to its own satisfaction the scope of the Project and nature of any other contracts that have been or may be awarded by the City in prosecution of the Project to the end that Contractor may perform this Contract in the light of such other contracts, if any. Nothing herein contained shall be interpreted as granting to Contractor exclusive occupancy at site of the Project. Contractor shall not cause any unnecessary hindrance or delay to any other contractor working on the Project. If simultaneous execution of any contract for the Project is likely to cause interference with performance of some other contract or contracts, the Engineer shall decide which Contractor shall cease Work temporarily and which contractor shall continue or whether work can be coordinated so that contractors may proceed simultaneously. The City shall not be responsible for any damages suffered or for extra costs incurred by Contractor resulting directly or indirectly from award, performance, or attempted performance of any other contract or contracts on the Project Site.

### **2-5 The Contractor's Equipment and Facilities.**

#### **2-5.2 Temporary Utility Services.**

**Section 2-5.2** of the Greenbook shall be **amended** to include the following:

All temporary utilities, including but not limited to electricity, water, gas, and telephone, used on the Work shall be furnished and paid for by Contractor.

Contractor shall provide necessary temporary distribution systems, including meters, if necessary, from distribution points to points on the Work where the utility is needed. Upon completion of the Work, Contractor shall remove all temporary distribution systems. Contractor shall provide necessary and adequate utilities and pay all costs for water, electricity, gas, oil, and sewer charges required for completion of the Work, including but not limited to startup and testing required in the Contract Documents. All permanent meters installed shall be listed in the Contractor's name until the Work is accepted. For Work to be performed in existing City facilities, Contractor may use the City's existing utilities, provided such use is reasonable under the circumstances. If Contractor uses the City utilities, it will not need to compensate the City for reasonable consumption of utilities, but Contractor will be responsible for any excessive, unreasonable or wasteful utility usage. Amounts due the City under this section may be deducted from progress payments.

A new **Section 2-11** hereby is **added** to Section 2 of the Greenbook, as follows:

**2-11 Substitution Requests, Schedule of Submittals, and Schedule.**

- A. Substitution Requests. Within fifteen (15) Days after Notice of Award (unless otherwise specified in the Contract Documents), Contractor shall provide all substitution requests as further described in Section 4-9.
- B. Schedule of Submittals. Within five (5) Days after the issuance of the Notice of Proceed (unless otherwise specified in the Contract Documents), Contractor shall submit to the City a Schedule of Submittals that conforms with the requirements of Section 5-22.
- C. Schedule. Within ten (10) days after the issuance of the Notice of Proceed (unless otherwise specified in the Contract Documents), the Contractor shall submit a construction schedule that conforms with the requirements of Section 6-1.1.

## **SECTION 3 CONTROL OF THE WORK**

### **3-3 Subcontractors.**

**Section 3-3** of the Greenbook shall be **amended** to include the following:

Contractor agrees to bind every Subcontractor to the terms of the Contract Documents as far as such terms are applicable to Subcontractor's portion of the Work. Contractor shall be as fully responsible to the City for the acts and omissions of its subcontractors and of persons either directly or indirectly employed by its subcontractors, as Contractor is for acts and omissions of persons directly employed by Contractor. Nothing contained in these Contract Documents shall create any contractual relationship between any subcontractor and the City.

The City reserves the right to accept all subcontractors. The City's acceptance of any Subcontractor under this Contract shall not in any way relieve Contractor of its obligations in the Contract Documents.

Prior to substituting any Subcontractor listed in the Bid Forms, Contractor must comply with the requirements of the Subletting and Subcontracting Fair Practices Act pursuant to California Public Contract Code section 4100 et seq.

### **3-4 Authority of the Board and the Engineer.**

**Section 3-4** of the Greenbook shall be **replaced** in its entirety with the following:

The Board has the final authority in all matters affecting the Work. Within the scope of the Contract, the Engineer has the authority to enforce compliance with the Contract Documents. The Contractor shall promptly comply with instructions from the Engineer.

The decision of the Engineer is final and binding on all questions relating to:

1. quantities;
2. acceptability of material, equipment, or work;
3. execution, progress or sequence of work;
4. interpretation of the Plans, Specifications, or other Contract Documents; and
5. Any other areas specifically identified in the Contract Documents or under the law.

Compliance with instructions from the Engineer shall be a condition precedent to any payment under the Contract, unless otherwise ordered by the Board.

### **3-5 Inspection.**

**Section 3-5** of the Greenbook shall be **amended** to include the following:

The Contractor shall give the Engineer notice of the time when he or his subcontractors will start the various units of operations of the work. Notice shall be given at least forty-eight (48) hours in advance of starting or resumption time exclusive of Saturdays, Sundays or holidays, for the purpose of permitting the Engineer to make the necessary assignment of his representative or inspector on the work. Any work performed by the Contractor or his subcontractors in conflict with said notice shall be removed if so ordered by the Engineer or his representative or inspector on the work.

The inspection of the work shall not relieve the Contractor of any of his obligations to fulfill the contract as prescribed. Defective work shall be made good, and unsuitable materials may be rejected, notwithstanding the fact that such defective work or unsuitable materials may have been previously overlooked by the Engineer and accepted or estimated for payment.

Any project undertaken by the Agency in cooperation with, or under the control or supervision of, another public or quasi-public entity shall be subject, at all times, to inspection by the participating entity.

### **3-7 Contract Documents.**

#### **3-7.1 General.**

New **Section 3-7.1.1 thru 3-7.1.6** hereby are **added** to Section 3-7.1 of the Greenbook, as follows,

**3-7.1.1 Examination of Contract Documents; Site.** Before commencing any portion of the Work, Contractor shall again carefully examine all applicable Contract Documents, the Project Site, and other information given to Contractor as to materials and methods of construction and other Project requirements. Contractor shall immediately notify the Engineer of any potential error, inconsistency, ambiguity, conflict, or lack of detail or explanation. If Contractor performs, permits, or causes the performance of any Work which is in error, inconsistent or ambiguous, or not sufficiently detailed or explained, Contractor shall bear any and all resulting costs, including, without limitation, the cost of correction. In no case shall the Contractor or any Subcontractor proceed with Work if uncertain as to the applicable requirements.

**3-7.1.2 Additional Instructions.** After notification of any error, inconsistency, ambiguity, conflict, or lack of detail or explanation, the Engineer will provide any required additional instructions, by means of drawings or other written direction, necessary for proper execution of Work.

**3-7.1.3 Quality of Parts, Construction and Finish.** All parts of the Work shall be of the best quality of their respective kinds and the Contractor must

use all diligence to inform itself fully as to the required construction and finish.

**3-7.1.4 Contractor's Variation from Contract Document Requirements.** If it is found that the Contractor has varied from the requirements of the Contract Documents including the requirement to comply with all Applicable Laws, the Engineer may at any time, before or after completion of the Work, order the improper Work removed, remade or replaced by the Contractor at the Contractor's expense.

**3-7.1.5 Intent of Contract Documents.** The Contract Documents are complementary; what is required by any one will be binding as if required by all. It is the intent of the Contract Documents to describe a functionally complete Project (or part thereof) to be constructed in accordance with the Contract Documents. Any labor, documentation, services, materials, or equipment that reasonably may be inferred from the Contract Documents or from prevailing custom or trade usage as being required to produce the indicated result will be provided whether or not specifically called for, at no additional cost to the City.

The Contractor shall furnish, unless otherwise provided in the Contract Documents, all materials, implements, machinery, equipment, tools, supplies and labor necessary to the prosecution and completion of the Project.

Clarifications and interpretations of the Contract Documents shall be issued by the Engineer as provided in these General Conditions.

If utilities to equipment/fixtures are not shown but are necessary to operate the equipment/fixtures, the utilities service installation is considered to be part of the Work. The implied Work will conform to the appropriate sections of the Contract Documents.

Organization of the Contract Documents into divisions, sections, and articles, and arrangement of drawings shall not control the Contractor in dividing Work among Subcontractors or in establishing the extent of Work to be performed by any trade.

**3-7.1.6 Reference Standards.** Reference to federal specifications, federal standards, other standards, specifications, manuals, or codes of any technical society, organization, or association, or to Applicable Laws, whether such reference be specific or by implication, shall mean the standard, specification, manual, code, or Applicable Laws in effect at the time of opening of Bids (or on the Effective Date of the Contract if there were no Bids), except as may be otherwise specifically stated in the Contract Documents.

No provision of any such standard, specification, manual, or code, or any instruction of a Supplier, shall be effective to change the duties or responsibilities of the City, Contractor, or any of their Subcontractors,

consultants, agents, or employees, from those set forth in the Contract Documents. No such provision or instruction shall be effective to assign to the City, or any of their officers, directors, members, partners, employees, agents, consultants, or subcontractors, any duty or authority to supervise or direct the performance of the Work or any duty or authority to undertake responsibility inconsistent with the provisions of the Contract Documents.

### **3-7.2 Precedence of the Contract Documents.**

**Section 3-7.2** of the Greenbook is **amended** to include the following:

The Contract Documents are intended to be fully cooperative and complementary. Before undertaking each part of the Work, Contractor shall carefully study and compare the Contract Documents and check and verify pertinent figures therein and all applicable field measurements. Contractor shall promptly report in writing to the City any conflict, error, ambiguity, or discrepancy which Contractor discovers, should have discovered, or has actual knowledge of, and shall obtain a written interpretation or clarification from the City before proceeding with any Work affected thereby. If, during the performance of the Work, Contractor discovers any conflict, error, ambiguity, or discrepancy within the Contract Documents, or between the Contract Documents and (i) any Applicable Law, (ii) any standard, specification, manual, or code, or (iii) any instruction of any Supplier, then Contractor shall promptly submit a written Request for Information (RFI) to the City. Contractor shall not proceed with the Work affected thereby (except in an emergency) until an amendment or supplement to the Contract Documents has been issued by one of the methods indicated in the Contract Documents, and any Work performed by Contractor before receipt of an amendment or supplement shall be at Contractor's own risk.

A new **Section 3-7.3** hereby is **added** to Section 3-7 of the Greenbook, as follows,

**3-7.3 Amending and Supplementing Contract Documents.** The Contract Documents may be amended to provide for additions, deletions, and revisions in the Work or to modify the terms and conditions thereof only by Change Order or written amendment to the Contract duly executed by the parties. The requirements of the Contract Documents may be supplemented, and minor variations and deviations in the Work may be authorized at no cost to the City, by one or more of the following ways:

1. The City's review of a Submittal, Shop Drawing, Sample or substitution request without exception (subject to the provisions of the Contract Documents); or
2. The City's issuance of a response to an RFI.

However, no review or RFI response will reduce or modify the Contractor's obligation to fully satisfy and comply with the requirements of the Contract Documents.

A new **Section 3-7.4** hereby is **added** to Section 3-7 of the Greenbook, as follows,

**3-7.4 Reuse of Documents.** Contractor and any Subcontractor or Supplier shall not:

1. have or acquire any title to or ownership rights in any of the Drawings, Specifications, or other documents (or copies of any thereof) prepared by or bearing the seal of Engineer of Record or its consultants, including electronic media editions; or
2. reuse any such Drawings, Specifications, other documents, or copies thereof on extensions of the Project or any other project without written consent of the City and Engineer of Record and specific written verification or adaptation by Engineer of Record.

The prohibitions of this Article will survive final payment, or termination of the Contract. Nothing herein shall preclude Contractor from retaining copies of the Contract Documents for record purposes.

**3-8 Submittals.**

**3-8.1 General.**

New **Section 3-8.1.1 through 3-8.1.3** shall be **added** to Section 3-8.1 of the Greenbook, as follows,

**3-8.1.1 Schedule of Submittals.** Within five (5) Days after the Notice to Proceed (unless otherwise specified in the Contract Documents), Contractor will prepare and deliver a Schedule of Submittals to the City that has been fully integrated with the progress schedule and identifies each Submittal required by the Contract Documents as well as the date on which Contractor will deliver each Submittal to the City. Each Submittal must be delivered to the City at least thirty (30) Days prior to the date the material or equipment is scheduled to be incorporated into the Work. The Contractor is responsible for any schedule delays resulting from the Submittal process.

**3-8.1.2 Submittal Procedures.** Contractor will follow the following procedures for each Submittal, Shop Drawing and Sample required by the Contract Documents:

- a. Submittals must be transmitted electronically.
- b. Transmittals will be sequentially numbered. Contractor to mark revised Submittals with original number and sequential alphabetic suffix.
- c. Each Submittal will identify the Project, Contractor, Subcontractor and Supplier, pertinent Drawing and detail number, and Specification Section number appropriate to Submittal.
- d. By transmitting a Submittal, Contractor certifies it has reviewed and approved each Submittal, verified products required, field dimensions, adjacent construction Work, and that coordination of

information is according to requirements of the Work and Contract Documents.

- e. Identify variations in Contract Documents and product or system limitations that may differ and/or be detrimental to successful performance of completed Work.
- f. When Submittal is revised for resubmission, Contractor shall promptly address the City's comments and resubmit. Contractor shall identify changes made since previous submission.
- g. The City's review of Shop Drawings shall not relieve Contractor from responsibility for deviations from the Contract Documents unless Contractor has, in writing, called the City's attention to such deviations at time of submission and the City has taken no exception to the deviation. The City's review of Shop Drawings shall not relieve Contractor from responsibility for errors in Shop Drawings.
- h. Submittals not required by the Contract Documents or requested by the City will not be acknowledged or processed.
- i. Incomplete Submittals will not be reviewed by the City. Delays resulting from incomplete Submittals are not the responsibility of the City.
- j. Contractor shall not be entitled to any extension of the Contract Times as a result of the Submittal process.
- k. Contractor shall allow a minimum of 20 working days for review of Submittals unless otherwise specified in the Contract Documents.

Where a Submittal, Shop Drawing or Sample is required by the Contract Documents or the Schedule of Submittals, any related Work performed prior to the City review and approval of the pertinent submittal will be performed at the sole risk and expense and responsibility of Contractor.

**3-8.1.3 Schedule Milestone for Submittals.** Contractor must submit all Submittals required by the Contract Documents in accordance with the Schedule of Submittals. If Contractor fails to submit the Submittals in accordance with the Schedule of Submittals, Contractor will be solely liable for any delays or impacts caused by the delayed Submittal, whether direct or indirect. Contractor will be liable for the time calculated from the date the Submittal is due until the date a compliant Submittal is made. A compliant Submittal will be one that is complete and satisfies the requirements of the Contract Documents.3-8.3 Shop Drawings.

**Section 3-8.3** of the Greenbook shall be **amended** to include the following:

1. Data shown on the Shop Drawings will be complete with respect to quantities, dimensions, specified performance and design criteria, materials, and similar data to show the City the services, materials, and equipment Contractor

proposes to provide and to enable the City to review the information for assessing conformance with information given and design concept expressed in Contract Documents.

2. When required by individual Specification sections, provide Shop Drawings signed and sealed by a professional engineer responsible for designing components shown on Shop Drawings. Shop Drawings must include signed and sealed calculations to support design in a form suitable for submission to and approval by authorities having jurisdiction.
3. Shop Drawings for steel structures shall consist of shop details, erection and other working Drawings showing details, dimensions, sizes of members and other information necessary for the complete fabrication and erection of the metal work.
4. Shop Drawings of concrete structures shall consist of such detailed drawings as may reasonably be required for the successful prosecution of the Work and which are not included in the Drawings furnished by the Engineer. These may include drawings for false work, bracing, centering and form work, masonry layout diagrams, and diagrams for bent reinforcement.
5. Contractor shall make revisions and provide additional information when required by authorities having jurisdiction.

New **Section 3-8.3.1 through 3-8.3.3** shall be **added** to Section 3-8.3 of the Greenbook, as follows,

**3-8.3.1 Submittal.** Before submitting each Shop Drawing or Sample, Contractor shall have:

1. Reviewed and coordinated each Shop Drawing or Sample with other Shop Drawings and Samples and with the requirements of the Work and the Contract Documents;
2. Determined and verified all field measurements, quantities, dimensions, specified performance and design criteria, installation requirements, materials, catalog numbers, and similar information with respect thereto;
3. Determined and verified the suitability of all materials offered with respect to the indicated application, fabrication, shipping, handling, storage, assembly, and installation pertaining to the performance of the Work; and
4. Determined and verified all information relative to Contractor's responsibilities for means, methods, techniques, sequences, and procedures of construction, and safety precautions and programs incident thereto.

**3-8.3.2 Notice of Variations.** With each Submittal, Contractor shall give the City specific written notice of any variations that the Shop Drawing or Sample may have from the requirements of the Contract Documents. This notice shall be both a written communication separate from the Shop Drawings or Sample Submittal and, in addition, a specific notation made on each Shop Drawing or Sample submitted to the City for review and approval of each such variation.

**3-8.3.3 Samples.** Clearly identify each Sample as to material, Supplier, pertinent data such as catalog numbers, the use for which intended and other data as required to enable the City to review the submittal for assessing conformance with information given and design concept expressed in Contract Documents. Samples should be of appropriate size and detail to assess functional, aesthetic, color, texture, patterns and finish selection.

**3-8.3.4 City's Review.**

1. The City will review Shop Drawings and Samples in accordance with the Schedule of Submittals. The City's review and acceptance will be only to determine if the items covered by the Submittals will, after installation or incorporation in the Work, conform to the information given in the Contract Documents and be compatible with the design concept of the completed Project as a functioning whole as indicated by the Contract Documents.
2. The City review and approval will not extend to means, methods, techniques, sequences, or procedures of construction (except where a particular means, method, technique, sequence, or procedure of construction is specifically and expressly called for by the Contract Documents) or to safety precautions or programs incident thereto. The review and approval of a separate item as such will not indicate approval of the assembly in which the item functions.
3. The City's review and acceptance shall not relieve Contractor from responsibility for any variation from the requirements of the Contract Documents unless the City has given written approval of each such variation by specific written notation thereof incorporated in or accompanying the Shop Drawing or Sample.

**3-8.3.5 Resubmittal Procedures.** Contractor shall make corrections required by the City and shall return corrected Shop Drawings and submit, as required, new Samples for review and approval. Contractor shall direct specific attention in writing to revisions other than the corrections called for by the City on previous Submittals.

**3-9 Subsurface Data.**

**Section 3-9** of the Greenbook shall be **amended** to include the following:

When a soils investigation report for the Site is available, such report is provided for informational purposes only. Any information obtained from such report as to subsurface soil condition, or to elevations of existing grades or elevations of underlying rock, is approximate only and is not guaranteed. Contractor acknowledges that any soils investigation report (including any borings) was prepared for purposes of design only and Contractor is required to examine the Site before submitting its Bid and must make whatever tests it deems appropriate to determine the condition of the soil.

City of Upland geology is an alluvial fan. These soil conditions are such that large rock cobble and boulders may be encountered during excavation. The Contractor shall be responsible for the removal and disposal of unsuitable material.

### **3-10 Surveying.**

**Section 3-10** of the Greenbook shall be **amended** to include the following:

#### **3-10.1 General.**

**Section 3-10.1** of the Greenbook shall be amended to include the following paragraph:

The Contractor is responsible to hire a Registered Civil Engineer or a Licensed Land Surveyor authorized to practice land surveying within the State of California to provide construction surveying, staking, and layout surveys required for the control and completion of the work, and all necessary surveys to compute quantities of Work performed, at the expense of the Contractor.

A new **Section 3-10.2** shall be **added** to **Section 3-10** of the Greenbook, as follows,

**3-10.2 Permanent Survey Markers:** The Contractor shall notify the Engineer, or the owner on a Private Contract, at least 7 days before starting work to allow for the preservation of survey monuments, lot stakes (tagged), and bench marks. The Contractor's Registered Land Surveyor, or Registered Civil Engineer authorized to practice land surveying, shall file a Corner Record Form referencing survey monuments subject to disturbance in the Office of the County Surveyor prior to the start of construction, and also prior to the completion of construction for the replacement of survey monuments. The Contractor shall not disturb survey monuments, lot stakes (tagged), or bench marks without the consent of the Engineer, or the owner on Private Contracts. The Contractor shall bear the expense of replacing any that may be disturbed without permission. Replacement shall be done only under the direction of the Engineer by Registered (licensed) Licensed Land Surveyor or a Registered Civil Engineer authorized to practice land surveying within the State of California. The Contractor's surveyor shall file all Corner records with the County of San Bernardino, with all costs paid by the Contractor.

When a change is made in the finished elevation of the pavement of any roadway in which a permanent survey monument is located, the Contractor shall adjust the monument cover to the new grade within seven (7) days of finished paving unless otherwise required by the Agency.

## **3-12 Work Site Maintenance.**

### **3-12.1 General.**

New **Section 3-12.1.1 through 3-12.1.4** hereby are **added** to Section 3-12.1 of the Greenbook, as follows,

**3-12.1.1 Sanitary Facilities.** Contractor shall provide sanitary temporary toilet buildings and hand washing facilities for the use of all workers. All toilets and hand washing facilities shall comply with local codes and ordinances. Toilets shall be placed inside sealed secondary containment devices installed on a flat, level surface. Accumulated liquids in the secondary containment devices shall be properly removed and legally disposed without spillage onto the ground. Toilets shall be kept supplied with toilet paper and shall have workable door fasteners. Toilets and hand washing facilities shall be serviced no less than once weekly and shall be present in a quantity of not less than 1 per 20 workers as required by Cal/OSHA regulations. The toilets and hand washing facilities shall be maintained in a sanitary condition at all times. Use of toilet and hand washing facilities in the Work under construction shall not be permitted. Any other sanitary facilities required by Cal/OSHA shall be the responsibility of the Contractor.

**3-12.1.2 Limitation of Use of Site and Other Areas.** Rights-of-way, easements, or rights-of-entry for the Work will be provided by the City. Unless otherwise specified in the Special Provisions, the Contractor shall make arrangements, pay for, and assume all responsibility for acquiring, using, and disposing of additional work areas and facilities temporarily required. The Contractor shall indemnify and hold the City harmless from all claims for damages caused by such actions. Contractor shall confine construction equipment, the storage of materials and equipment, and the operations of workers to the Site and other areas permitted by Applicable Laws, and shall not unreasonably encumber the Site and other areas with construction equipment or other materials or equipment. Contractor shall assume full responsibility for any damage to any such land or area, or to City or occupant thereof, or of any adjacent land or areas resulting from the performance of the Work.

**3-12.1.3 Site Maintenance.** During the progress of the Work, Contractor shall keep the Site and other areas free from accumulations of waste materials, rubbish, and other debris. Removal and disposal of such waste materials, rubbish, and other debris shall conform to Applicable Laws. The Contractor shall furnish trash bins for all debris from construction. All debris shall be placed in trash bins daily. Forms and false-work that are to be re-used shall be stacked neatly concurrently with their removal. Forms and false-work that are not to be re-used shall be disposed of concurrently with their removal.

**3-12.1.4 Cleaning.** Prior to Completion of the Work, Contractor shall clean the Site and make it ready for utilization by the City. At the completion of the

Work Contractor shall remove from the Site all tools, appliances, construction equipment and machinery, and surplus materials and shall restore to original condition all property not designated for alteration by the Contract Documents.

**Section 3-12.2** of the Greenbook is **amended** to read as follows:

**3-12.2 Dust and Air Pollution Control.**

**3-12.2.1 Dust Control.** Contractor, at its expense, shall maintain all excavations, embankments, haul roads, permanent access roads, plant sites, waste disposal areas, borrow areas, and all other work areas free from dust. Industry accepted methods of dust control suitable for the area involved, such as sprinkling, chemical treatment, light bituminous treatment or similar methods, will be permitted.

**3-12.2.2 Air Pollution Control.** Contractor shall comply with all air pollution control rules, regulations, ordinances and statutes. All containers of paint, thinner, curing compound, solvent or liquid asphalt shall be labeled to indicate that the contents fully comply with the applicable material requirements.

Without limiting the foregoing, Contractor must fully comply with all applicable laws, rules and regulations in furnishing or using equipment and/or providing services, including, but not limited to, emissions limits and permitting requirements imposed by the Air Quality Management District with jurisdiction over the Project and/or California Air Resources Board (CARB). Contractor shall specifically be aware of the application of these limits and requirements to "portable equipment", which definition includes any item of equipment with a fuel-powered engine. Contractor shall indemnify the City against any fines or penalties imposed by the air quality management district, CARB, or any other governmental or regulatory agency for its violations of Applicable Laws as well as those of its subcontractors or others for whom Contractor is responsible under its indemnity obligations provided for in the Contract Documents.

**Section 3-12.3** of the Greenbook is **amended** to read as follows:

**3-12.3 Noise Control.**

- A. Contractor shall use only such equipment on the Work and in such state of repair so that the emission of sound therefrom is within the noise tolerance level of that equipment as established by Cal/OSHA. Contractor shall comply with the most restrictive of the following: (1) local sound control and noise level rules, regulations and ordinances and (2) the requirements contained in these Contract Documents, including hours of operation requirements.
- B. No internal combustion engine shall be operated on the Project without a muffler of the type recommended by the manufacturer. Should any muffler or other control device sustain damage or be determined to be ineffective or defective, the Contractor shall promptly remove the equipment and shall not return said equipment to the job until the device is repaired or replaced. Said noise and vibration level requirements shall apply to all equipment on the job or related to the job, including but not limited to, trucks, transit mixers or transit equipment that may or may not be owned by the Contractor.

**3-12.6 Water Pollution Control.**

**3-12.6.1 General.**

**Section 3-12.6.1** of the Greenbook shall be **amended** to include the following:

- f) Storm, surface, ground, nuisance, or other waters may be encountered at various times during construction of the Work. The Contractor hereby acknowledges that it has investigated the risk arising from such waters, has prepared its Bid accordingly, and assumes any and all risks and liabilities arising therefrom.
- g) Contractor shall keep itself and all subcontractors, staff, and employees fully informed of and in compliance with all local, state and federal laws, rules and regulations that may impact, or be implicated by the performance of the Work including, without limitation, all applicable provisions regulating discharges of storm water; the Federal Water Pollution Control Act (33 U.S.C. § 13000 et seq.); the California Porter-Cologne Water Quality Control Act (Cal Water Code §§ 13000-14950); and any and all regulations, policies, or permits issued pursuant to any such authority. These include, but are not limited to California State Water Resources Control Board Order Number 2009-0009-DWQ (NPDES Permit No. CAS000002), as amended by Order Numbers 2010-0014-DWQ, 2012-0006-DWQ, and any subsequent amendment to or renewal thereof, State Water Resources Control Board Order No. 2013-0001-DWQ (NPDES Order No. CAS000004), Santa Ana Regional Water Quality Control Board No. R8-2010-0036 (NPDES No. CAS618036), and any amendment or renewal thereof.

- h) Contractor shall comply with all conditions of the State Water Resources Control Board (“State Water Board”) National Pollutant Discharge Elimination System General Permit for Waste Discharge Requirements for Discharges of Storm Water Runoff Associated with Construction Activity (“Construction General Permit”) for all construction activity which results in the disturbance of in excess of one acre of total land area or which is part of a larger common area of development or sale. Contractor shall comply with the lawful requirements of the City, and any other applicable municipality, drainage district, or other local agency with jurisdiction over the location where the Work is to be conducted, regarding discharges of storm water to separate storm drain systems or other watercourses under their jurisdiction, including applicable requirements in municipal storm water management programs.
  
- i) Unless otherwise specified in the Special Conditions or other portion of the Contract Documents, the City has not prepared a Storm Water Pollution Prevention Plan (“SWPPP”) or other storm water compliance plan for the Project Site. Contractor shall be responsible for filing the Notice of Intent (“NOI”) and for obtaining coverage under the Construction General Permit. This includes filing all necessary documentation including the Permit Registration Documents (“PRDs”) through the Stormwater Multiple Applications and Report Tracking System (“SMARTS”); preparing and implementing a SWPPP for the Work site; implementing all other provisions, and monitoring and reporting requirements required by the Construction General Permit; and providing a Qualified SWPPP Developer (“QSD”) and Qualified SWPPP Practitioner (“QSP”), as necessary for all Work site activities, including but not limited to preparation and submittal of all reports, plans, inspections, and monitoring information in compliance with the Construction General Permit. All submittals shall be coordinated with the City’s Legally Responsible Person and Authorized Signatory as those terms are defined in the Construction General Permit. Before any NOI, PRD, SWPPP, or other Construction General Permit-related document may be submitted to the State Water Board or implemented on the Project site, it must first be reviewed and approved by the City and/or City’s designee. Contractor shall include all costs of compliance with specified requirements in the Contract Price.

The City retains the right to develop its own documentation for the Project site, including but not limited to the SWPPP, and in the alternative may require Contractor to adopt and implement portions of the City developed SWPPP. The City expressly reserves the right to procure coverage under the Construction General Permit for the Work site if Contractor fails to draft satisfactory PRDs or SWPPP or otherwise fails to proceed in a manner that complies with the requirements of the Construction General Permit. The City additionally reserves the right to hire additional contractors to maintain compliance at the Work site. Whether Contractor has adequately maintained compliance with the Construction General

Permit shall be the City's sole determination. Any costs incurred by the City in procuring coverage under the Construction General Permit, or drafting and/or implementing a SWPPP for the Work site shall be paid by Contractor.

Notwithstanding the above, for those Work sites where construction activity results in the disturbance of less than one acre of total land area and/or do not need coverage under the Construction General Permit, the Contractor shall be responsible for preparing and implementing an Erosion and Sediment Control Plan in accordance with State Water Resources Control Board Order No. 2013-0001-DWQ (NPDES Order No. CAS000004) and any amendment to or renewal thereof.

Failure to comply with the Construction General Permit, laws, regulations, and ordinances listed in this Article is a violation of federal and state law. Notwithstanding any other indemnity contained in these Contract Documents, Contractor agrees to indemnify and hold harmless the City, its officials, officers, agents, employees and authorized volunteers from and against any and all claims, demands, fees, costs, expenses, or losses or liabilities of any kind or nature which the City, its officials, officers, agents, employees and authorized volunteers may sustain or incur for noncompliance with the Permit, laws, regulations, and ordinances listed above, arising out of or in connection with the Work, except for liability resulting from the sole established negligence, willful misconduct or active negligence of the City, its officials, officers, agents, employees or authorized volunteers.

The City reserves the right to defend any enforcement action or civil action brought against the City for Contractor's failure to comply with any applicable water quality law, regulation, or policy. Contractor hereby agrees to be bound by, and to reimburse the City for the costs associated with, any settlement reached between the City and any relevant enforcement entity.

### **3-13 Completion, Acceptance, and Warranty.**

#### **3-13.1 Completion.**

**Section 3-13.1** of the Greenbook shall be **amended** to read as follows:

The Contractor shall submit a written assertion that the Work has been completed. Upon written notice from Contractor that the entire Work is complete, the Engineer will promptly make a final inspection with the City and Contractor and will notify Contractor in writing of all particulars in which this inspection reveals that the Work is incomplete or defective. Contractor shall immediately take such measures as are necessary to complete such Work or remedy such deficiencies. If, in the Engineer's judgement, the Work has been completed in accordance with the Contract Documents, the Engineer will set forth in writing the date the Work was completed. This will be the date when the Contractor is

relieved from responsibility to protect and maintain the Work and to which liquidated damages will be computed.

### **3-13.1.1 Defective Work Correction.**

1. If Contractor fails within a reasonable time after written notice from the City to correct Defective Work, or to remove and replace rejected Work as required by the City, or if Contractor fails to perform the Work in accordance with the Contract Documents, or if Contractor fails to comply with any other provision of the Contract Documents, the City may, after seven (7) Days written notice to Contractor, correct, or remedy any such deficiency.
2. In connection with such corrective or remedial action, the City may exclude Contractor from all or part of the Site, take possession of all or part of the Work and suspend Contractor's services related thereto, take possession of Contractor's tools, appliances, construction equipment and machinery at the Site, and incorporate in the Work all materials and equipment stored at the Site or for which the City has paid Contractor but which are stored elsewhere. Contractor shall allow the City, and the agents, employees, other contractors, and consultants of each of them, access to the Site to enable the City to exercise the rights and remedies to correct the Defective Work.
3. All claims, costs, losses, and damages (including but not limited to all fees and charges of engineers, architects, attorneys, and other professionals and all court or arbitration or other dispute resolution costs) incurred or sustained by the City correcting the Defective Work will be charged against Contractor, and a Change Order will be issued incorporating the necessary revisions in the Contract Documents with respect to the Work; and the City shall be entitled to an appropriate decrease in the Contract Price. Such claims, costs, losses and damages will include but not be limited to all costs of repair, or replacement of work of others destroyed or damaged by correction, removal, or replacement of defective Work.
4. If the Change Order is executed after all payments under the Contract have been paid by the City and the Project Retention is held in an escrow account as permitted by the Contract Documents, Contractor will promptly alert the escrow holder, in writing, of the amount of Retention to be paid to the City. If the Change Order is executed after release of the Project retention, an appropriate amount will be paid by Contractor to the City. Contractor shall not be allowed an extension of the Contract Times because of any delay in the performance of the Work attributable to the City correcting Defective Work.

5. Nothing in the warranty or in the Contract Documents shall be construed to limit the rights and remedies available to the City at law or in equity, including, but not limited to, Code of Civil Procedure section 337.15.

### **3-13.2 Acceptance.**

**Section 3-13.2** of the Greenbook shall be **amended** to read as follows:

The acceptance of the Work on behalf of the City will be made by the Engineer. Such acceptance by the City shall not constitute a waiver of defects. After Contractor has, in the opinion of the Engineer, satisfactorily completed all corrections identified during the final inspection and has delivered, in accordance with the Contract Documents, all maintenance and operating instructions, schedules, guarantees, bonds, certificates or other evidence of insurance, certificates of inspection, Record Documents, and other documents required by the Contract Documents, the City shall execute a Notice of Completion, constituting final acceptance and completion of the Project, except as may be expressly noted.

If, instead of requiring correction or removal and replacement of defective Work, the City prefers to accept it, the City may do so. Contractor shall pay all claims, costs, losses, and damages (including but not limited to all fees and charges of engineers, architects, attorneys, and other professionals and all court or arbitration or other dispute resolution costs) attributable to the City's evaluation of and determination to accept such defective Work and for the diminished value of the Work. If any acceptance of Defective Work occurs prior to release of the Project retention, a Change Order will be issued incorporating the necessary revisions in the Contract Documents with respect to the Work, and the City shall be entitled to an appropriate decrease in the Contract Price, reflecting the diminished value of Work and all costs incurred by the City. If the acceptance of defective occurs after release of the Project retention, an appropriate amount will be paid by Contractor to the City.

### **3-13.3 Warranty.**

**Section 3-13.3** of the Greenbook shall be **amended** to read as follows:

- A. Contractor hereby warrants that materials and Work shall be completed in conformance with the Contract Documents and that the materials and Work provided will fulfill the requirements of this Warranty. Contractor hereby agrees to repair or replace, at the discretion of the City, any or all Work that may prove to be defective in its workmanship, materials furnished, methods of installation or fail to conform to the Contract Document requirements together with any other Work which may be damaged or displaced by such defect(s) within a period of one (1) year (or as otherwise indicated in the Contract Documents or in any guarantee or warranty provided by any manufacturer or supplier of equipment or materials incorporated into the Work, whichever is later) from the date of the Notice of Completion of the Project without any expense whatever to the City, ordinary wear and tear and

unusual abuse and neglect excepted. Contractor shall be required to promptly repair or replace defective equipment or materials, at Contractor's option. All costs associated with such corrective actions and testing, including the removal, replacement, and reinstatement of equipment and materials necessary to gain access, shall be the sole responsibility of the Contractor.

- B. For any Work so corrected, Contractor's obligation hereunder to correct defective Work shall be reinstated for an additional one (1) year period, commencing with the date of acceptance of such corrected Work. The reinstatement of the one (1) year warranty shall apply only to that portion of work that was corrected. Contractor shall perform such tests as the City may require to verify that any corrective actions, including, without limitation, redesign, repairs, and replacements comply with the requirements of the Contract. In the event of Contractor's failure to comply with the above-mentioned conditions within ten (10) Days after being notified in writing of required repairs, to the reasonable satisfaction of the City, the City shall have the right to correct and replace any defective or non-conforming Work and any work damaged by such work or the replacement or correction thereof at Contractor's sole expense. Contractor shall be obligated to fully reimburse the City for any expenses incurred hereunder immediately upon demand. If the Contractor fails to reimburse the Agency for the actual costs, the Contractor's Surety shall be liable for the cost thereof.
- C. In addition to the warranty set forth in this Article, Contractor shall obtain for the City all warranties that would be given in normal commercial practice and assign to the City any and all manufacturer's or installer's warranties for equipment or materials not manufactured by Contractor and provided as part of the Work, to the extent that such third-party warranties are assignable and extend beyond the warranty period set forth in this Article. Contractor shall furnish the City with all warranty and guarantee documents prior to final acceptance of the Project by the City as required.
- D. When specifically indicated in the Contract Documents or when directed by the Engineer, the City may furnish materials or products to the Contractor for installation. In the event any act or failure to act by Contractor shall cause a warranty applicable to any materials or products purchased by the City for installation by the Contractor to be voided or reduced, Contractor shall indemnify the City from and against any cost, expense, or other liability arising therefrom, and shall be responsible to the City for the cost of any repairs, replacement or other costs that would have been covered by the warranty but for such act or failure to act by Contractor.
- E. The Contractor shall remedy at its expense any damage to City-owned or controlled real or personal property.
- F. The City shall notify the Contractor, in writing, within a reasonable time after the discovery of any failure, defect, or damage. The Contractor shall within ten (10) Days after being notified commence and perform with due diligence all necessary Work. If the Contractor fails to promptly remedy any defect or

damage, the City shall have the right to replace, repair or otherwise remedy the defect, or damage at the Contractor's expense.

- G. In the event of any emergency constituting an immediate hazard to health, safety, property, or licensees, when caused by Work of the Contractor not in accordance with the Contract requirements, the City may undertake at Contractor's expense, and without prior notice, all Work necessary to correct such condition.

A new **Section 3-14** hereby is **added** to Section 3 of the Greenbook, as follows,

**3-14 Meetings.**

- 3-14.1 Preconstruction Conference.** Before any Work at the Site is started, a conference attended by the City, Contractor, Engineer, and others as appropriate will be held to establish a working understanding among the parties as to the Work and to discuss the schedules referred to herein, procedures for handling Submittals and Shop Drawings, processing applications for payment, and maintaining required records.
- 3-14.2 Subcontractor Mobilization Meeting.** Prior to the start of each major Subcontractor's Site Work, the Contractor, the involved Subcontractor, and Engineer shall attend a pre-start meeting to discuss the schedule, coordination, procedures, and other administrative issues.
- 3-14.3 Progress Meetings.** The Contractor shall schedule and hold regular progress meetings at least weekly and at other times as requested by Engineer or as required by progress of the Work. The Contractor, City, and all Subcontractors active on the Site shall attend each meeting. Contractor may at its discretion request attendance by representatives of its Suppliers, manufacturers, and other Subcontractors. The City will preside at the progress meetings and will arrange for keeping and distributing the minutes. The purpose of the meetings is to review the progress of the Work, maintain coordination of efforts, discuss changes in scheduling, and resolve other problems which may develop. During each meeting, the Contractor shall present any issues which may impact its progress with a view to resolve these issues expeditiously.

A new **Section 3-15** hereby is **added** to Section 3 of the Greenbook, as follows,

**3-15 Record ("As-Built") Drawings.**

- A. The Contractor shall maintain one record set of Contract Documents at the Site or digitally in an acceptable format. On these, it shall mark all Project conditions, locations, configurations, and any other changes or deviations which may vary from the information represented in the original Contract Documents, including buried or concealed construction and utility features which are revealed during the course of construction. Special attention shall be given to recording the horizontal and vertical location of all buried utilities that differ from the locations indicated, or which were not indicated on the Drawings. For all Projects involving the installation of any pipeline, Contractor shall survey and record the top of the pipe at a minimum of every 100 linear feet, and at each bend, recording both the horizontal and vertical locations. Said

Drawings shall be supplemented by any detailed sketches as necessary or directed to fully indicate the Work as actually constructed. Any required as-built drawings of civil engineering elements of the Work shall be prepared by a registered civil engineer.

- B. These master Record Drawings of the as-built conditions, including all revisions made necessary by Addenda and Change Orders, shall be maintained up-to-date during the progress of the Project. Red ink shall be used for alterations and notes. Notes shall identify relevant Change Orders by number and date. Record Drawings shall be accessible to the Engineer at all times during the construction period. Failure on the Contractor's part to keep Record Drawings current could result in withholding partial payment.
- C. Upon completion of the Project and as a condition of final acceptance, the Contractor shall finalize and deliver a complete set of Record Drawings to the Engineers. The information submitted by the Contractor will be assumed to be correct, and the Contractor shall be responsible for, and liable to the City, for the accuracy of such information, and for any errors or omissions which may or may not appear on the Record Drawings.
- D. Unless otherwise called for by the Contract Documents, the cost of all material, equipment, and labor required to complete the Record Drawings shall be included in Contractor's bid and distributed in the Bid Schedule. No additional compensation shall be made to the Contractor for this Work.

A new **Section 3-16** hereby is **added** to Section 3 of the Greenbook, as follows,

**3-16 Ownership of Site Materials Found.** The title to water, soil, rock, gravel, sand, minerals, timber and any other materials developed or obtained in the excavation or other operations of Contractor or any of its Subcontractors in the performance of the Contract, and the right to use said items in carrying out the Contract, or to dispose of same, is hereby expressly reserved by the City. Neither Contractor nor any of its Subcontractors nor any of their representatives or employees shall have any right, title, or interest in said materials, nor shall they assert or make any claim thereto. Contractor will, as determined by the City's Representative, be permitted to use in the Work without charge, any such materials which meet the requirements of the Contract Documents, provided the City shall have the right to use or consume these materials without payment to a third party.

A new **Section 3-17** hereby is **added** to Section 3 of the Greenbook, as follows,

**3-17 Existence of Utilities at the Work Site.**

**3-17.1 Existing Utilities.**

1. The location of known existing utilities and pipelines are shown on the Plans in their approximate locations. However, nothing herein shall be deemed to require the City to indicate the presence of existing service laterals or appurtenances whenever the presence of such utilities on the site of the project can be inferred from the presence of other visible facilities, such as buildings, cleanouts, meter and junction boxes, on or adjacent to the Site of the Project.

2. The City will assume the responsibility for the timely removal, relocation, or protection of existing main or trunk line utility facilities located on the Project site if such utilities are not identified by the City in the Contract Documents or which cannot reasonably be inferred from the presence of other visible facilities.

### **3-17.2 Utility Location.**

1. It shall be the Contractor's responsibility to determine the exact location and depth of all utilities, including service connections, which have been marked by the respective utility owners and which the Contractor believes may affect or be affected by the Contractor's operations. The Contractor shall not be entitled to additional compensation nor time extensions for work necessary to avoid interferences nor for repair to damaged utilities if the Contractor does not expose all such existing utilities as required by this Article.
2. The locating of utilities shall be in conformance with Government Code Section 4216 et seq. except for the City's utilities located on the City's property and not on public right-of-way.
3. A "High Priority Subsurface Installation" is defined in Government Code Section 4216 (j) as "high-pressure natural gas pipelines with normal operating pressures greater than 415kPA gauge (60psig) or greater than six inches nominal pipe diameter, petroleum pipelines, pressurized sewage pipelines, high-voltage electric supply lines, conductors, or cables that have a potential to ground of greater than or equal to 60kv, or hazardous materials pipelines that are potentially hazardous to workers or the public if damaged."
4. A "Subsurface Installation" is defined in Government Code Section 4216 (s) as "any underground pipeline, conduit, duct, wire, or other structure, except nonpressurized sewer lines, nonpressurized storm drains, or other nonpressurized drain lines."
5. Pursuant to Government Code Section 4216.2 the Contractor shall contact the appropriate regional notification center at least two (2) working days but not more than 14 Days before performing any excavation. The date of the notification shall not count as part of the two-working-day notice. Before notifying the appropriate regional notification center, the Contractor shall delineate the area to be excavated. The Contractor shall request that the utility owners conduct a utility survey and mark or otherwise indicate the location of their service. The Contractor shall furnish to the Engineer written documentation of its contact(s) with the regional notification center prior to commencing excavation at such locations.
6. After the utility survey is completed, the Contractor shall commence "potholing" or hand digging to determine the actual location of the pipe, duct, or conduit and in accordance with Government Code Section 4216.4 if the excavation within the "tolerance zone" of a subsurface installation. The Engineer shall be given notice prior to commencing potholing operations. The Contractor shall uncover all piping and conduits, to a point one (1) foot below the pipe, where

crossings, interferences, or connections are shown on the Drawings, prior to trenching or excavating for any pipe or structures, to determine actual elevations. New pipelines shall be laid to such grade as to clear all existing facilities, which are to remain in service for any period subsequent to the construction of the run of pipe involved.

7. The Contractor's attention is directed to the requirements of Government Code Section 4216.2 (c) which provides: "When the excavation is proposed within 10 feet of a high priority subsurface installation, the operator of the high priority subsurface installation shall notify the excavator of the existence of the high priority subsurface installation to set up an onsite meeting prior to the legal excavation start date and time or at a mutually agreed upon time to determine actions or activities required to verify the location and prevent damage to the high priority subsurface installation. As part of the meeting, the excavator shall discuss with the operator the method and tools that will be used during the excavation and the information the operator will provide to assist in verifying the location of the subsurface installation. The excavator shall not begin excavating until after the completion of the onsite meeting." The Contractor shall notify the Engineer in advance of this meeting.

### **3-17.3 Utility Relocation and Repair.**

1. If interferences occur at locations other than those indicated in the Contract Documents with reasonable accuracy, the Contractor shall notify the Engineer in writing. The Engineer will supply a method for correcting said interferences in accordance with the responsibilities of this section and Government Code Section 4215. To the extent any delay is caused thereby, Contractor shall submit a notice of delay within five (5) Days of discovery of the circumstances giving rise to the delay in accordance with Article 9.1 Change Orders and Time Extensions.
2. Care shall be exercised by the Contractor to prevent damage to adjacent existing facilities and public or private works; where equipment will pass over these obstructions, suitable planking shall be placed. If high priority subsurface installations are damaged and the operator cannot be contacted, the Contractor shall call 911 emergency services.
3. The City will compensate the Contractor for the costs of locating and repairing damage not due to the failure of the Contractor to exercise reasonable care, and for removing or relocating such main or trunk line utility facilities not indicated in the Contract Documents with reasonable accuracy, and for the cost of equipment on the Project necessarily idled during such work. The payment for such costs will be made as provided in Article 9.1 Change Orders and Time Extensions. The Contractor shall not be assessed liquidated damages for delay in completion of the Project, when such delay is caused by the failure of the City or utility company to provide for removal or relocation of such utility facilities. Requests for extensions of time arising out of utility relocation or repair delays shall be filed in accordance with Article 9.1 Change Orders and Time Extensions and Article 9.3 Time for Completion and Liquidated Damages.

4. The public utility, where it is the owner of the affected utility, shall have the sole discretion to perform repairs or relocation work or permit the Contractor to do such repairs or relocation work at a reasonable price. The right is reserved to the City and the owners of utilities or their authorized agents to enter upon the Work area for the purpose of making such changes as are necessary for the rearrangement of their facilities or for making necessary connections or repairs to their properties. The Contractor shall cooperate with forces engaged in such work and shall conduct its operations in such a manner as to avoid any unnecessary delay or hindrance to the work being performed by such forces and shall allow the respective utilities time to relocate their facility.
5. When the Contract Documents indicate that a utility is to be relocated, altered or constructed by others, the City will conduct all negotiations with the utility company and the work will be done at no cost to the Contractor, unless otherwise stipulated in the Contract Documents.
6. Temporary or permanent relocation or alteration of utilities desired by the Contractor for its own convenience shall be the Contractor's responsibility and it shall make arrangements and bear all costs for such work.

#### **3-17.4 Construction at Existing Utilities.**

1. Where the Work to be performed crosses or otherwise interferes with water, sewer, gas, or oil pipelines; buried cable; or other public or private utilities, the Contractor shall perform construction in such a manner so that no damage will result to either public or private utilities. It shall be the responsibility of the Contractor to determine the actual locations of, and make accommodations to maintain, all utilities.
2. Before any utility is taken out of service, permission shall be obtained by the Contractor from the owner. The owner, any impacted resident or business owner and the City Representative will be advised of the nature and duration of the utility outage as well as the Contractor's plan for providing temporary utilities if required by the owner. The Contractor shall be liable for all damage which may result from its failure to maintain utilities during the progress of the Work, and the Contractor shall indemnify City as required by the Contract Documents from all claims arising out of or connected with damage to utilities encountered during construction; damages resulting from disruption of service; and injury to persons or damage to property resulting from the negligent, accidental, or intentional breaching of utilities.
3. Unless otherwise called for by the Contract Documents, the cost of all material, equipment, and labor required to complete this work, shall be included in Contractor's bid and distributed in the schedule of pay Items. No additional compensation shall be made to the Contractor for this work.

A new **Section 3-18** hereby is **added** to Section 3 of the Greenbook, as follows,

#### **3-18 Trenches.**

**3-18.1 Trenches Five Feet or More in Depth.** Contractor shall submit to the Engineer at the preconstruction meeting, a detailed plan showing the design of shoring, bracing, sloping or other provisions to be made for worker protection from hazards of caving ground during the excavation of any trench or trenches five feet or more in depth. If such plan varies from shoring system standards established by the Construction Safety Orders of the California Code of Regulations, Department of Industrial Relations, the plan shall be prepared by a California registered civil or structural engineer. The plan shall not be less effective than the shoring, bracing, sloping, or other provisions of the Construction Safety Orders, as defined in the California Code of Regulations. The Contractor shall designate in writing the "competent person" as defined in Title 8, California Code of Regulations, who shall be present at the Work Site each day that trenching/excavation is in progress. The "competent person" shall prepare and provide daily trenching/excavation inspection reports to the Engineer. Contractor shall also submit a copy of its annual California Occupational Safety and Health Administration (Cal/OSHA) trench/excavation permit.

**3-18.2 Excavations Deeper than Four Feet.**

1. If the Work involves excavating trenches or other excavations that extend deeper than four (4) feet below the surface, Contractor shall promptly within three (3) Days, and before the excavation is further disturbed, notify the City in writing of any of the following conditions:
  - a. Material that the Contractor believes may be material that is hazardous waste, as defined in section 25117 of the Health and Safety Code, that is required to be removed to a Class I, Class II, or Class III disposal site in accordance with provisions of existing law.
  - b. Subsurface or latent physical conditions at the site differing from those indicated.
  - c. Unknown physical conditions at the site of any unusual nature, different materially from those ordinarily encountered and generally recognized as inherent in work of the character provided for in the Contract.
2. The City shall promptly investigate the conditions, and if it finds that the conditions do so materially differ, or do involve hazardous waste, and cause a decrease or increase in Contractor's cost of, or the time required for, performance of any part of the Work, shall issue a Change Order under the procedures described in Article 9.1 Change Orders and Time Extensions.
3. In the event that a dispute arises between the City and the Contractor as to whether the conditions materially differ, or involve hazardous waste, or cause a decrease or increase in the Contractor's cost of, or time required for, performance of any part of the Work, the Contractor shall not be excused from any scheduled completion date provided for by the Contract, but shall proceed with all Work to be performed under the Contract. Contractor shall retain any and all rights provided either by contract or by law which pertain to the resolution of disputes and protests between the parties.

## **SECTION 4 CONTROL OF MATERIALS**

### **4-1 General.**

**Section 4-1** of the Greenbook shall be **amended** to include the following:

- A. Except as otherwise specifically stated in the Contract Documents, Contractor shall provide and pay for all materials, labor, tools, equipment, water, lights, power, transportation, superintendence, temporary constructions of every nature, and all other services and facilities whatsoever necessary to execute and complete this Contract within the Contract Time. Unless otherwise specified, all materials, parts, and equipment furnished by the Contractor in the Work shall be new, the best of their respective kinds and grades as noted and/or specified, and workmanship shall be of good quality.
- B. No materials, supplies, or equipment for Work under this Contract shall be purchased subject to any chattel mortgage or under a conditional sale or other agreement by which an interest therein or in any part thereof is retained by the seller or supplier. Contractor warrants good title to all material, supplies, and equipment installed or incorporated in the Work and agrees upon completion of all work to deliver the Project, to the City free from any claims, liens, or charges.
- C. Materials shall be furnished in ample quantities and at such times as to ensure uninterrupted progress of the Work and shall be stored properly and protected as required by the Contract Documents. Contractor shall be entirely responsible for damage or loss by weather or other causes to materials or Work. Materials shall be stored on the Project Site in such manner so as not to interfere with any operations of the City or any independent contractor.
- D. Contractor shall verify all measurements, dimensions, elevations, and quantities before ordering any materials or performing any Work, and the City shall not be liable for Contractor's failure to do so. Except for an adjustment to Unit Price Work for item overruns and underruns in accordance with the Contract Documents, no additional compensation, over and above payment for the actual quantities at the prices set out in the Bid Schedule, will be allowed because of differences between actual measurements, dimension, elevations and quantities and those indicated on the Plans and in the Specifications. Any difference therein shall be submitted to the Engineer for consideration before proceeding with the Work.

### **4-2 Protection.**

**Section 4-2** of the Greenbook shall be **amended** to include the following:

- A. The Contractor shall digitally record video and take photographs of the Project site and adjacent improvements in a manner and quality that clearly depicts the existing

condition of the Project Site and adjacent improvements immediately prior to the start of Work (minimum 1080p video and 4MP photo). All videos and photographs shall be date and time stamped. The Contractor shall submit the video and photos in digital format on a memory stick before the commencement of Work, along with a map outlining the route and locations of the videos and/or photographs. The Contractor shall be responsible for all damages to persons or property that occur as a result of the Work. Contractor shall be responsible for the proper care and protection of all materials delivered and Work performed until completion and final acceptance by the City. All Work shall be solely at the Contractor's risk.

- B. Contractor shall adequately protect adjacent property from settlement or loss of lateral support as necessary. Contractor shall comply with all applicable safety laws and building codes to prevent accidents or injury to persons on, about, or adjacent to the Project site where Work is being performed. Contractor shall erect and properly maintain at all times, as required by field conditions and progress of work, all necessary safeguards, signs, barriers, lights, and watchmen for protection of workers and the public, and shall post danger signs warning against hazards created in the course of construction.
- C. Contractor shall provide such heat, covering, and enclosures as are necessary to protect all Work, materials, equipment, appliances, and tools against damage by weather conditions.
- D. Contractor shall take adequate precautions to protect existing sidewalks, curbs, pavements, utilities, and other adjoining property and structures, and to avoid damage thereto, and Contractor shall repair any damage thereto caused by the Work operations. Contractor shall:
  - 1. Enclose the working area with a substantial barricade, and arrange work to cause minimum amount of inconvenience and danger to the public.
  - 2. Provide substantial barricades around any shrubs or trees indicated to be preserved.
  - 3. Deliver materials to the Site over a route designated by the City.
  - 4. Provide any and all dust control required and follow the applicable air quality regulations as appropriate. If the Contractor does not comply immediately with a notice from the City or a public agency responsible for air quality, the City shall have the authority to provide dust control and deduct the cost from payments to the Contractor.
  - 5. Confine Contractor's apparatus, the storage of materials, and the operations of its workers to limits required by law, ordinances, permits, or directions of the City. Contractor shall not unreasonably encumber the Site with its materials.
  - 6. Take care to prevent disturbing or covering any survey markers, monuments, or other devices marking property boundaries or corners. If such markers are disturbed by accident, they shall be replaced by a civil engineer or land surveyor acceptable to the City, at no cost to the City.

7. Ensure that existing facilities, fences, and other structures are all adequately protected and that, upon completion of all Work, all facilities that may have been damaged are restored to a condition acceptable to the City.
  8. Preserve and protect from injury all buildings, pole lines and all directional, warning and mileage signs that have been placed within the right-of-way.
  9. At the completion of work each day, leave the Work and the Site in a clean, safe condition.
  10. Comply with any stage construction and/or traffic handling plans. Access to residences and businesses shall be maintained at all times, except with the City's written approval. Any request for approval to reduce or restrict access to residences and business must be submitted to the City at least seven (7) Days in advance, and the City may issue or withhold approval in its sole discretion.
- E. These precautionary measures will apply continuously and not be limited to normal working hours. Full compensation for the work involved in the protection and preservation of life, safety and property as above specified shall be considered as included in the prices paid for the various contract items of Work, and no additional allowance will be made therefor.
- F. Should damage to persons or property occur as a result of the Work, Contractor shall promptly notify the City, in writing. Contractor shall be responsible for proper investigation, documentation, including video or photography, to adequately memorialize and make a record of what transpired. The City shall be entitled to inspect and copy any such documentation, video, or photographs.
- G. Contractor shall maintain all investigation documentation including video and/or photographs for a minimum of four (4) years following completion of the Project.

#### **4-3 Inspection.**

##### **4-3.1 General.**

**Section 4-3.1** of the Greenbook shall be **amended** to include the following:

1. If the Contract Documents, the Engineer, or any instructions, laws, ordinances, or public authority requires any part of the Work to be tested or approved, Contractor shall provide the Engineer at least two (2) working days' notice of its readiness for observation or inspection. If inspection is by a public authority other than the City, Contractor shall promptly inform the City of the date fixed for such inspection. Required certificates of inspection (or similar) shall be secured by Contractor. Costs for City testing and inspection shall be paid by the City. Costs of tests for Work found not to be in compliance shall be paid by the Contractor.
2. The Contractor shall pay for the cost of any minimum "show up" costs of a materials testing technician that was called for by the Contractor but ultimately the Contractor work was not ready for the inspection. Any such costs shall be deducted from any amounts due to the Contractor.

3. If any Work is done or covered up without the required testing or approval, the Contractor shall uncover or deconstruct the Work, and the Work shall be redone after completion of the testing at the Contractor's cost in compliance with the Contract Documents.
4. Where inspection and testing are to be conducted by an independent laboratory or agency, materials or samples of materials to be inspected or tested shall be selected by such laboratory or agency, or by the City, and not by Contractor. Unless otherwise stated and as provided by the Contract Documents, the City shall employ and pay for the services of an independent testing laboratory to perform all inspections, tests, or approvals required by the Contract Documents. All tests or inspections of materials shall be made in accordance with the commonly recognized standards of national organizations.
5. Reexamination of Work may be ordered by the City. If so ordered, Work must be uncovered or deconstructed by Contractor. If Work is found to be in accordance with the Contract Documents, the City shall pay the costs of reexamination and reconstruction. If such work is found not to be in accordance with the Contract Documents, Contractor shall pay all costs.

#### **4-4 Testing.**

**Section 4-4** of the Greenbook shall be **amended** to include the following:

1. In advance of manufacture of materials to be supplied by Contractor which must be tested or inspected, Contractor shall notify the City so that the City may arrange for testing at the source of supply. Any materials which have not satisfactorily passed such testing and inspection shall not be incorporated into the Work.
2. If the manufacture of materials to be inspected or tested will occur in a plant or location greater than sixty (60) miles from the City, the Contractor shall pay for any excessive or unusual costs associated with such testing or inspection, including but not limited to excessive travel time, standby time and required lodging.
3. Unless otherwise specified in the Special Provisions, all initial testing and a reasonable amount of retesting will be performed under the direction of the Engineer, and at no expense to the Contractor. The Contractor shall notify the Engineer in writing, at least 15 days in advance, of its intention to use materials for which tests are specified, to allow sufficient time to perform the tests. The notice shall name the proposed supplier and source of material. If the notice of intent to use is sent before the materials are available for testing or inspection, or is sent so far in advance that the materials on hand at the time will not last but will be replaced by a new lot prior to use on the Work, it will be the Contractor's responsibility to re-notify the Engineer when samples which are representative may be obtained.
4. A Certificate of Compliance shall be furnished to the Engineer prior to the use of any material or assembled material for which these Specifications so require or if so required by the Engineer. The Engineer may waive the materials testing requirements and accept a Certificate of Compliance. Material test data may be required by the

Engineer to be included with the submittal. Materials used on the basis of a Certificate of Compliance may be sampled and tested at any time. The submission of a Certificate of Compliance shall not relieve the Contractor of responsibility for incorporating material into the Work which conforms to the requirements of the Contract Documents, and any material not conforming to the requirements will be subject to rejection by the Engineer whether in place or not.

5. Copies of mill certificates of composition and quality of all component materials (reinforcing steel, structural steel, lumber, etc.) incorporated in the construction of the Work shall be provided to the City at the time of delivery. City shall retain the right to reject any raw material not provided with a mill certificate at the time of delivery.
6. If, after incorporating such materials into the Work, it is found that sources of supply that have been approved do not furnish a uniform product, or if the product from any source proves unacceptable at any time, the Contractor shall furnish approved material from other approved sources. If any product proves unacceptable after improper storage, handling or for any other reason it shall be rejected, not incorporated into the Work, and shall be removed from the Project Site all at the Contractor's expense.

A new **Section 4-9** hereby is **added** to Section 4 of the Greenbook, as follows,

**4-9 Requests for Substitutions.**

- A. For the purposes of this provision, the term "substitution" shall mean the substitution of any material, method, or service substantially equal to or better in every respect to that indicated in the Standard Specifications or otherwise referenced herein.
- B. Pursuant to Public Contract Code section 3400(b), the City may make a finding that is described in the Notice Inviting Bids that designates certain products, things, or services by specific brand or trade name.
- C. Unless specifically designated in the Special Conditions, whenever any material, process, or article is indicated or specified by grade, patent, or proprietary name or by name of manufacturer, such specifications shall be deemed to be used for the purpose of facilitating the description of the material, process, or article desired and shall be deemed to be followed by the words "or equal." Contractor may, unless otherwise stated, offer for substitution any material, process, or article which may be substantially equal to or better in every respect to that so indicated or specified in the Contract Documents. However, the City has adopted uniform standards for certain materials, processes, and articles.
- D. The Contractor shall submit substitution requests, together with substantiating data, for substitution of any "or equal" material, process, or article no later than thirty-five (35) calendar days after award of Contract. Provisions regarding submission of substitution requests shall not in any way authorize an extension of time for the performance of this Contract. If a substitution request is rejected by the City, the Contractor shall provide the material, method or service specified herein. The City shall not be responsible for any costs incurred by the Contractor associated with substitution requests. The burden of proof as to the equality of any material, process,

or article shall rest with the Contractor. The Engineer has the complete and sole discretion to determine if a material, process, or article is substantially equal to or better than that specified and to approve or reject all substitution requests.

- E. Substantiating data as described above shall include, at a minimum, the following information:
  - 1. A signed affidavit from the Contractor stating that the material, process, or article proposed as a substitution is substantially equal to or better than that specified in every way except as may be listed on the affidavit.
  - 2. Illustrations, specifications, catalog cut sheets, and any other relevant data required to prove that the material, process, or article is substantially equal to or better than that specified.
  - 3. A statement of the cost implications of the substitution being requested, indicating whether and why the proposed substitution will reduce or increase the amount of the contract.
  - 4. Information detailing the durability and lifecycle costs of the proposed substitution.
- F. Failure to submit all the required substantiating data detailed above in a timely manner so that the substitution request can be adequately reviewed may result in rejection of the substitution request. The Engineer is not obligated to review multiple submittals related to the same substitution request resulting from the Contractor's failure to initially submit a complete package.
- G. Time limitations within this Article shall be strictly complied with and in no case will an extension of time for completion of the contract be granted because of Contractor's failure to provide substitution requests at the time and in the manner described herein.
- H. The Contractor shall bear the costs of all the City work associated with the review of substitution requests.
- I. If substitution requests approved by the Engineer require that Contractor furnish materials, methods, or services more expensive than that specified, the increased costs shall be borne by Contractor.

## SECTION 5 LEGAL RELATIONS AND RESPONSIBILITIES

**Section 5-0** of the Greenbook is hereby **added** to read as follows:

**5-0 General.** All references in Section 5 to the Division of Industrial Safety shall mean the State Division of Occupational Safety and Health, or its successor agency or agencies.

### **5-1 Laws and Regulations.**

New **Section 5-1.1 through 5-1.5** hereby are **added** to Section 5-1 of the Greenbook, as follows,

**5-1.1 Indemnification.** To the fullest extent permitted by law, Contractor shall immediately defend (with counsel of the City's choosing), indemnify, and hold harmless the City, its officials, officers, agents, employees, and representatives, and each of them from and against:

1. Any and all claims, demands, causes of action, costs, expenses, injuries, losses or liabilities, in law or in equity, of every kind or nature whatsoever, but not limited to, injury to or death, including wrongful death, of any person, and damages to or destruction of property of any person, arising out of, related to, or in any manner directly or indirectly connected with the Work or this Contract, including claims made by subcontractors for nonpayment, including without limitation the payment of all consequential damages and attorney's fees and other related costs and expenses, however caused, regardless of whether the allegations are false, fraudulent, or groundless, and regardless of any negligence of the City or its officers, employees, or authorized volunteers (including passive negligence), except the sole negligence or willful misconduct or active negligence of the City or its officials, officers, employees, or authorized volunteers.
2. Contractor's defense and indemnity obligation herein includes, but is not limited to damages, fines, penalties, attorney's fees and costs arising from claims under the Americans with Disabilities Act (ADA) or other federal or state disability access or discrimination laws arising from Contractor's Work during the course of construction of the improvements or after the Work is complete, as the result of defects or negligence in Contractor's construction of the improvements.
3. Any and all actions, proceedings, damages, costs, expenses, fines, penalties or liabilities, in law or equity, of every kind or nature whatsoever, arising out of, resulting from, or on account of the violation of any governmental law or regulation, compliance with which is the responsibility of Contractor.
4. Any and all losses, expenses, damages (including damages to the Work itself), attorney's fees, and other costs, including all costs of defense which any of them may incur with respect to the failure, neglect, or refusal of Contractor to faithfully perform the Work and all of Contractor's obligations under Contract. Such costs, expenses, and damages shall include all costs, including attorney's fees, incurred by the indemnified parties in any lawsuit to which they are a party.

Contractor shall immediately defend, at Contractor's own cost, expense, and risk, with the counsel of the City choosing, any and all such aforesaid suits, actions or other legal proceedings of every kind that may be brought or instituted against the City, its officials, officers, agents, employees and representatives. Contractor shall pay and satisfy any judgment, award or decree that may be rendered against the City, its officials, officers, employees, agents, employees and representatives, in any such suit, action or other legal proceeding. Contractor shall reimburse the City, its officials, officers, agents, employees and representatives for any and all legal expenses and costs incurred by each of them in connection therewith or in enforcing the indemnity herein provided. The only limitations on this provision shall be those imposed by Civil Code section 2782.

The provisions of this Article shall survive the termination of this Contract howsoever caused, and no payment, partial payment, or acceptance of occupancy in whole or part of the Work shall waive or release any of the provisions of this Article.

**5-1.2 Applicable Laws.** Contractor shall give all notices required by and shall comply with all Applicable Laws applicable to the performance of the Work. Except where otherwise expressly required by Applicable Laws, neither the City nor the City's Representative shall be responsible for monitoring Contractor's compliance with any Applicable Laws. If Contractor performs any Work knowing or having reason to know that it is contrary to Applicable Laws, Contractor shall bear all claims, costs, losses, and damages (including but not limited to all fees and charges of engineers, architects, attorneys, and other professionals and all court or arbitration or other dispute resolution costs) arising out of or relating to such Work.

**5-1.3 Permits and Licenses.** Permits and licenses necessary for prosecution of the Work shall be secured and paid for by Contractor, including, but not limited to, excavation permit, for plumbing, mechanical and electrical work and for operations in or over public streets or right of way under jurisdiction of public agencies other than the City, unless otherwise specified in the Contract Documents.

The Contractor shall arrange and pay for all off-site inspection of the Work related to permits and licenses, including certification, required by the specifications, drawings, or by governing authorities, except for such off-site inspections delineated as the City's responsibility pursuant to the Contract Documents.

Before acceptance of the Work, the Contractor shall submit all licenses, permits, certificates of inspection and required approvals to the City.

**5-1.4 Independent Contractors.**

A. Contractor shall be an independent contractor for the City and not an employee. Contractor understands and agrees that it and all of its employees shall not be considered officers, employees, or agents of the City and are not

entitled to benefits of any kind normally provided employees of the City, including but not limited to, state unemployment compensation or workers' compensation. Contractor assumes full responsibility for the acts and omissions of its employees or agents related to the Work.

- B. In the event that Contractor or any employee, agent, or subcontractor of Contractor providing services under this Agreement claims or is determined by a court of competent jurisdiction or the California Public Employees Retirement System ("PERS") to be eligible for enrollment in PERS as an employee of the City, Contractor shall indemnify, defend, and hold harmless City for the payment of any employee and/or employer contributions for PERS benefits on behalf of Contractor or its employees, agents, or subcontractors, as well as for the payment of any penalties and interest on such contributions, which would otherwise be the responsibility of City.
- C. Notwithstanding any other agency, state or federal policy, rule, regulation, law or ordinance to the contrary, Contractor and any of its employees, agents, and subcontractors providing service under this Agreement shall not qualify for or become entitled to, and hereby agree to waive any claims to, any compensation, benefit, or any incident of employment by City, including but not limited to eligibility to enroll in PERS as an employee of City and entitlement to any contribution to be paid by City for employer contribution and/or employee contributions for PERS benefits.

**5-1.5 Verification of Employment Eligibility.** By executing the Contract, Contractor verifies that it fully complies with all requirements and restrictions of state and federal law respecting the employment of undocumented aliens, including, but not limited to, the Immigration Reform and Control Act of 1986, as may be amended from time to time, and shall require all subcontractors, sub-subcontractors, and consultants to comply with the same. Each person executing this Contract on behalf of Contractor verifies that he or she is a duly authorized officer of Contractor and that any of the following shall be grounds for the City to terminate the Contract for cause: (1) failure of the Contractor or its Subcontractors, sub-subcontractors or consultants to meet any of the requirements provided for in this Article; (2) any misrepresentation or material omission concerning compliance with such requirements; or (3) failure to immediately remove from the Work any person found not to be in compliance with such requirements.

**5-1.6 Public Works Contractor Registration.** Pursuant to Labor Code sections 1725.5 and 1771.1, the Contractor and its Subcontractors must be registered with the DIR prior to the execution of a contract to perform public works. By entering into this Contract, Contractor represents that it is aware of the registration requirement and is currently registered with the DIR. Contractor shall maintain a current registration for the duration of the Project. Contractor shall further include the requirements of Labor Code sections 1725.5 and 1771.1 in any subcontract and ensure that all Subcontractors are registered at the time this Contract is entered into and maintain registration for the duration of the Project. Notwithstanding the foregoing, the contractor registration requirements mandated by Labor Code Sections 1725.5 and 1771.1 shall not apply to work

performed on a public works project that is exempt pursuant to the small project exemption specified in Labor Code Sections 1725.5 and 1771.1.

## **5-3 Labor**

### **5-3.1 General.**

**Section 5-3.1** of the Greenbook is hereby **amended** to include the following paragraph as follows:

The Contractor shall at all times observe and comply with, and shall cause all his agents and employees to observe and comply with all such laws, ordinances, regulations, orders and decrees; and shall protect and indemnify the Agency, the Board and the Engineer, and all of its and their officers and agents and servants against any claim or liability arising from or based on the violation of any such law, ordinance, regulation, order or decree, whether by himself or his employees. If any such discrepancy or inconsistency is discovered in the plans, drawings, specifications, or contract for the work in relation to any such law, ordinance, regulation, order or decree, the Contractor shall forthwith report the same in writing to the Engineer.

**Section 5-3.2** of the Greenbook is **amended** to read as follows:

### **5-3.2 Prevailing Wage.**

1. The Contractor is aware of the requirements of Labor Code sections 1720 *et seq.* and 1770 *et seq.*, as well as California Code of Regulations, Title 8, Section 16000 *et seq.* ("Prevailing Wage Laws"), which require the payment of prevailing wage rates and the performance of other requirements on certain "public works" and "maintenance" projects. Since this Project involves an applicable "public works" or "maintenance" project, as defined by the Prevailing Wage Laws, and since the total compensation is \$1,000 or more, Contractor agrees to fully comply with such Prevailing Wage Laws. The Contractor shall obtain a copy of the prevailing rates of per diem wages at the commencement of this Contract from the website of the Division of Labor Statistics and Research of the Department of Industrial Relations located at [www.dir.ca.gov](http://www.dir.ca.gov). In the alternative, the Contractor may view a copy of the prevailing rate of per diem wages which are on file at the City's Administration Office and shall be made available to interested parties upon request. Contractor shall make copies of the prevailing rates of per diem wages for each craft, classification, or type of worker needed to perform work on the Project available to interested parties upon request, and shall post copies at the Contractor's principal place of business and at the Project site. Contractor shall defend, indemnify, and hold the City, its officials, officers, employees, and authorized volunteers free and harmless from any claims, liabilities, costs, penalties or interest arising out of any failure or alleged failure to comply with the Prevailing Wage Laws.
2. The Contractor shall forfeit as a penalty to the City not more than Two Hundred Dollars (\$200.00), pursuant to Labor Code section 1775, for each

calendar day, or portion thereof, for each worker paid less than the prevailing wage rate as determined by the Director of the DIR for such work or craft in which such worker is employed for any public work done under the Contract by it or by any Subcontractor under it. The difference between such prevailing wage rate and the amount paid to each worker for each calendar day or portion thereof, for which each worker was paid less than the prevailing wage rate, shall be paid to each worker by the Contractor.

3. Contractor shall post, at appropriate conspicuous points on the Project Site, a schedule showing all determined general prevailing wage rates and all authorized deductions, if any, from unpaid wages actually earned.

**Section 5-3.3** of the Greenbook is **amended** to read as follows:

**5-3.3 Payroll Records.**

1. Pursuant to Labor Code section 1776, Contractor and all subcontractors shall maintain weekly certified payroll records, showing the names, addresses, Social Security numbers, work classifications, straight time and overtime hours worked each day and week, and the actual per diem wages paid to each journeyman, apprentice, worker, or other employee employed by them in connection with the Work under this Contract. Contractor shall certify under penalty of perjury that records maintained and submitted by Contractor are true and accurate. Contractor shall also require Subcontractor(s) to certify weekly payroll records under penalty of perjury.
2. In accordance with Labor Code section 1771.4, the Contractor and each Subcontractor shall furnish the certified payroll records directly to the Department of Industrial Relations ("DIR") on the specified interval and format prescribed by the DIR, which may include electronic submission. Contractor shall comply with all requirements and regulations from the DIR relating to labor compliance monitoring and enforcement. The requirement to submit certified payroll records directly to the Labor Commissioner under Labor Code section 1771.4 shall not apply to work performed on a public works project that is exempt pursuant to the small project exemption specified in Labor Code Section 1771.4.
3. Any stop orders issued by the DIR against Contractor or any Subcontractor that affect Contractor's performance of Work, including any delay, shall be Contractor's sole responsibility. Any delay arising out of or resulting from such stop orders shall be considered Contractor caused delay subject to any applicable liquidated damages and shall not be compensable by the City. Contractor shall defend, indemnify, and hold the City, its officials, officers, employees, and agents free and harmless from any claim or liability arising out of stop orders issued by the DIR against Contractor or any Subcontractor.
4. The payroll records described herein shall be certified and submitted by the Contractor at a time designated by the City. The Contractor shall also provide the following:

- a. A certified copy of the employee's payroll records shall be made available for inspection or furnished to such employee or his or her authorized representative on request.
  - b. A certified copy of all payroll records described herein shall be made available for inspection or furnished upon request of the DIR.
5. Unless submitted electronically, the certified payroll records shall be on forms provided by the Division of Labor Standards Enforcement ("DLSE") of the DIR or shall contain the same information as the forms provided by the DLSE.
  6. Any copy of records made available for inspection as copies and furnished upon request to the public or any public agency, the City, the Division of Apprenticeship Standards, or the Division of Labor Standards Enforcement shall be marked or obliterated in such a manner as to prevent disclosure of an individual's name, address, and social security number. The name and address of the Contractor awarded the Contract or performing the Contract shall not be marked or obliterated.
  7. In the event of noncompliance with the requirements of this Article, the Contractor shall have ten (10) Days in which to comply subsequent to receipt of written notice specifying in what respects the Contractor must comply with this Article. Should noncompliance still be evident after such 10-day period, the Contractor shall pay a penalty of one hundred dollars (\$100.00) to the City for each calendar day, or portion thereof, for each worker, until strict compliance is effectuated. Upon the request of the Division of Apprenticeship Standards or the Division of Labor Standards Enforcement, such penalties shall be withheld from progress payment then due.
  8. The responsibility for compliance with this Article shall rest upon the Contractor.

**Section 5-3.4** of the Greenbook is **amended** to read as follows:

**5-3.4 Hours of Labor.**

1. As provided in Article 3 (commencing at section 1810), Chapter 1, Part 7, Division 2 of the Labor Code, Contractor stipulates that eight (8) hours of labor shall constitute a legal day's work. The time of service of any worker employed at any time by the Contractor or by any subcontractor on any subcontract under this Contract upon the Work or upon any part of the Work contemplated by this Contract is limited and restricted to eight (8) hours during any one calendar day and 40 hours during any one calendar week, except as hereinafter provided. The Contractor shall forfeit, as a penalty to the Agency, the maximum amount authorized under California Labor Code Section 1813 for each laborer, worker or mechanic employed in the execution of the contract, by him or any subcontractor under him, upon any of the work hereinbefore mentioned, for each calendar day during which said laborer, worker or mechanic is required or permitted to labor more than eight (8) hours in violation of said Labor Code.

Notwithstanding the provisions herein above set forth, work performed by employees of Contractor in excess of eight (8) hours per day, and 40 hours during any one week, shall be permitted upon this public work upon compensation for all hours worked in excess of eight (8) hours per day at not less than one and one-half times the basic rate of pay.

Contractor agrees to pay travel and subsistence pay to each worker needed to execute the work required by this contract as such travel and subsistence payments are defined in the applicable collective bargaining agreements filed in accordance with Labor Code § 1773.

2. The Contractor and every Subcontractor shall keep an accurate record showing the name of and actual hours worked each calendar day and each calendar week by each worker employed in connection with the Work or any part of the Work contemplated by this Contract. The record shall be kept open at all reasonable hours to the inspection of the City and to the Division of Labor Law Enforcement, Department of Industrial Relations of the State of California.
3. The Contractor shall pay to the City a penalty of twenty-five dollars (\$25.00) for each worker employed in the execution of this Contract by the Contractor or by any subcontractor for each calendar day during which such worker is required or permitted to work more than eight (8) hours in any calendar day and 40 hours in any one calendar week in violation of the provisions of Article 3 (commencing at section 1810), Chapter 1, Part 7, Division 2 of the Labor Code.
4. Any work necessary to be performed after regular working hours, or on Saturdays and Sundays or other holidays, shall be performed without additional expense to the City.
5. If Contractor gives notice of an inspection pursuant to the Contract Documents, the City will provide inspection during normal working hours from 7:00 a.m. to 3:30 p.m. Monday through Friday. Requested inspections before or after this time will be charged to the Contractor as reimbursable inspection time. Inspections on weekends requires two (2) Days' notice for review and approval. Upon written request and approval, the 8.5 hour working day may be changed to other limits subject to city/county ordinance.
6. It shall be unlawful for any person to operate, permit, use, or cause to operate any of the following at the Project Site, other than between the hours of 7:00 a.m. to 5:00 p.m., Monday through Friday, with no Work allowed on City-observed Holidays, unless otherwise approved by the City:
  - a. Powered Vehicles
  - b. Construction Equipment
  - c. Loading and Unloading Vehicles

d. Domestic Power Tools

**Section 5-3.5** is hereby **amended** to read as follows,

**5-3.5 Apprentices.** In accordance with the provisions of § 1777.5 of the Labor Code as amended by Chapter 971, Statutes of 1939, and in accordance with the regulations of the California apprenticeship Council, properly indentured apprentices may be employed in the prosecution of the work.

Attention is directed to the provisions in §§ 1777.5 and 1777.6 of the Labor Code concerning the employment of apprentices by the Contractor or any subcontractor under him.

Section 1777.5, as amended, requires the Contractor or subcontractor employing tradesmen in any apprenticeable occupation to apply to the joint apprenticeship committee nearest the site of the public works project and which administers the apprenticeship program in that trade for a certificate of approval. The certificate will also fix the ratio of apprentices to journeymen that will be used in the performance of the contract. The ratio of apprentices to journeymen in such cases shall not be less than one to five except:

- a. When unemployment in the area of coverage by the joint apprenticeship committee has exceeded an average of fifteen percent (15%) in the ninety (90) days prior to the request for certificate, or
- b. When the number of apprentices in training in the area exceeds a ratio of one to five, or
- c. When the trade can show that it is replacing at least 1/30 of its membership through apprenticeship training on an annual basis statewide or locally, or
- d. When the Contractor provides evidence that he employs registered apprentices on all of his contracts on an annual average of not less than one apprentice to eight journeymen.

The Contractor is required to make contributions to funds established for the administration of apprenticeship programs if he employs registered apprentices or journeymen in any apprenticeable trade on such contracts and if other contractors on the public works site are making such contributions.

Contractor and all Subcontractors shall comply with the requirements of Labor Code sections 1777.5 and 1777.6 in the employment of apprentices.

Information relative to apprenticeship standards, wage schedules and other requirements may be obtained from the director of Industrial Relations, *ex-officio* the Administrator of Apprenticeship, San Francisco, California, or from the Division of Apprenticeship Standards and its branch offices.

Knowing violations of Labor Code section 1777.5 will result in forfeiture not to exceed one hundred dollars (\$100.00) for each calendar day of non-compliance pursuant to Labor Code section 1777.7.

New **Section 5-3.6 and Section 5-3.7** hereby are **added** to Section 5-3 of the Greenbook, as follows,

**5-3.6 Nondiscrimination/ Equal Employment Opportunity.** Pursuant to Labor Code section 1735 and other applicable provisions of law, the Contractor and its Subcontractors shall not discriminate against any employee or applicant for employment because of race, religious creed, color, national origin, ancestry, physical disability, mental disability, medical condition, marital status, sex, age, sexual orientation, or any other classifications protected by law on this Project. The Contractor will take affirmative action to insure that employees are treated during employment or training without regard to their race, religious creed, color, national origin, ancestry, physical disability, mental disability, medical condition, marital status, sex, age, sexual orientation, or any other classifications protected by law.

**5-3.7 Debarment of Contractors and Subcontractors.** Contractors or Subcontractors may not perform work on a public works project with a subcontractor who is ineligible to perform work on a public project pursuant to Labor Code section 1777.1 or 1777.7. Any contract on a public works project entered into between a contractor and a debarred subcontractor is void as a matter of law. A debarred subcontractor may not receive any public money for performing work as a subcontractor on a public works contract. Any public money that is paid, or may have been paid, to a debarred subcontractor by a contractor on the project shall be returned to the City. The Contractor shall be responsible for the payment of wages to workers of a debarred subcontractor who has been allowed to work on the Project.

**Section 5-4** is hereby **amended** in its entirety to read as follows,

#### **5-4 Insurance**

The Contractor shall obtain, and at all times during performance of the Work of Contract, maintain all of the insurance described in this Article. Contractor shall not commence Work under this Contract until it has provided evidence satisfactory to the City that it has secured all insurance required hereunder. Contractor shall not allow any Subcontractor to commence work on any subcontract until it has provided evidence satisfactory to the City that the subcontractor has secured all insurance required under this Article. Failure to provide and maintain all required insurance shall be grounds for the City to terminate this Contract for cause. Contractor shall furnish the City with original certificates of insurance and endorsements effective coverage required by this Contract on forms satisfactory to the City. The certificates and endorsements for each insurance policy shall be signed by a person authorized by that insurer to bind coverage on its behalf, and shall be on forms acceptable to the City. All certificates and endorsements must be received and approved by the City before Work commences.

**A. Additional Insureds; Waiver of Subrogation.** The City, its officials, officers, employees, agents and authorized volunteers shall be named as Additional Insureds on Contractor's All Risk policy and on Contractor's and its subcontractors' policies of Commercial General Liability and Automobile Liability insurance using, for Contractor's policy/ies of Commercial General Liability insurance, ISO CG forms 20

10 and 20 37 (or endorsements providing the exact same coverage, including completed operations), and, for subcontractors' policies of Commercial General Liability insurance, ISO CG form 20 38 (or endorsements providing the exact same coverage). Notwithstanding the minimum limits set forth in this Contract for any type of insurance coverage, all available insurance proceeds in excess of the specified minimum limits of coverage shall be available to the parties required to be named as Additional Insureds hereunder. All insurance coverage maintained or procured pursuant to this Contract shall be endorsed to waive subrogation against the City, its officers, officials, agents, employees or volunteers or shall specifically allow Contractor – or others providing insurance evidence in compliance with these specifications – to waive their right of recovery prior to a loss. Contractor hereby waives its own right of recovery against the City, and shall require similar written express waivers and insurance clauses from each of its subcontractors. Copies of these waivers shall be submitted to the City prior to commencement of work.

- B. Workers' Compensation Insurance.** The Contractor shall provide workers' compensation insurance for all of the employees engaged in Work under this Contract, on or at the Site, and, in case of any sublet Work, the Contractor shall require the subcontractor similarly to provide workers' compensation insurance for all the latter's employees as prescribed by State law. Any class of employee or employees not covered by a subcontractor's insurance shall be covered by the Contractor's insurance. In case any class of employees engaged in work under this Contract, on or at the Site, is not protected under the Workers' Compensation Statutes, the Contractor shall provide or shall cause a subcontractor to provide, adequate insurance coverage for the protection of such employees not otherwise protected. The Contractor is required to secure payment of compensation to his employees in accordance with the provisions of section 3700 of the Labor Code. The Contractor shall file with the City certificates of his insurance protecting workers. Company or companies providing insurance coverage shall be acceptable to the City, if in the form and coverage as set forth in the Contract Documents.
- C. Employer's Liability Insurance.** Contractor shall provide Employer's Liability Insurance, including Occupational Disease, in the amount of at least one million dollars (\$1,000,000.00) per person per accident. Contractor shall provide the City with a certificate of Employer's Liability Insurance. Such insurance shall comply with the provisions of the Contract Documents. The policy shall be endorsed, if applicable, to provide a Borrowed Servant/Alternate Employer Endorsement and contain a Waiver of Subrogation in favor of the City.
- D. Commercial General Liability Insurance.** Contractor shall provide "occurrence" form Commercial General Liability insurance coverage at least as broad as the most current ISO CGL Form 00 01, including but not limited to, premises liability, contractual liability, products/completed operations, personal and advertising injury which may arise from or out of Contractor's operations, use, and management of the Site, or the performance of its obligations hereunder. The policy shall not contain any exclusion contrary to this Contract including but not limited to endorsements or provisions limiting coverage for (1) contractual liability (including but not limited to ISO CG 24 26 or 21 39); or (2) cross-liability for claims or suits against one insured against another. Policy limits shall not be less than \$2,000,000 per occurrence for bodily injury, personal injury and property damage. If Commercial General Liability Insurance or other form with a

general aggregate limit is used, either the general aggregate limit shall apply separately to this project/location or the general aggregate limit shall be twice the required occurrence limit. Defense costs shall be paid in addition to the limits.

1. Such policy shall comply with all the requirements of this Article. The limits set forth herein shall apply separately to each insured against whom claims are made or suits are brought, except with respect to the limits of liability. Further the limits set forth herein shall not be construed to relieve the Contractor from liability in excess of such coverage, nor shall it limit Contractor's indemnification obligations to the City, and shall not preclude the City from taking such other actions available to the City under other provisions of the Contract Documents or law.
2. All general liability policies provided pursuant to the provisions of this Article shall comply with the provisions of the Contract Documents.
3. All general liability policies shall be written to apply to all bodily injury, including death, property damage, personal injury, owned and non-owned equipment, blanket contractual liability, completed operations liability, explosion, collapse, under-ground excavation, removal of lateral support, and other covered loss, however occasioned, occurring during the policy term, and shall specifically insure the performance by Contractor of that part of the indemnification contained in these General Conditions relating to liability for injury to or death of persons and damage to property.
4. If the coverage contains one or more aggregate limits, a minimum of 50% of any such aggregate limit must remain available at all times; if over 50% of any aggregate limit has been paid or reserved, the City may require additional coverage to be purchased by Contractor to restore the required limits. Contractor may combine primary, umbrella, and as broad as possible excess liability coverage to achieve the total limits indicated above. Any umbrella or excess liability policy shall include the additional insured endorsement described in the Contract Documents.
5. All policies of general liability insurance shall permit and Contractor does hereby waive any right of subrogation which any insurer of Contractor may acquire from Contractor by virtue of the payment of any loss.

**E. Automobile Liability Insurance.** Contractor shall provide Automobile Liability Insurance at least as broad as ISO CA 00 01 (Any Auto) in the amount of, at least, one million dollars (\$1,000,000) per accident for bodily injury and property damage. Such insurance shall provide coverage with respect to the ownership, operation, maintenance, use, loading or unloading of any auto owned, leased, hired or borrowed by Contractor or for which Contractor is responsible, in a form and with insurance companies acceptable to the City. All policies of automobile insurance shall permit and Contractor does hereby waive any right of subrogation which any insurer of Contractor may acquire from Contractor by virtue of the payment of any loss.

- F. **Contractor's Pollution Liability Coverage.** Contractor shall provide pollution liability insurance in an amount not less than \$1,000,000 per occurrence and \$2,000,000 aggregate.
- G. Contractor shall require all tiers of Subcontractors working under this Contract to provide the insurance required under this Article unless otherwise agreed to in writing by the City. Contractor shall make certain that any and all Subcontractors hired by Contractor are insured in accordance with this Contract. If any Subcontractor's coverage does not comply with the foregoing provisions, Contractor shall indemnify and hold the City harmless from any damage, loss, cost, or expense, including attorneys' fees, incurred by the City as a result thereof.
- H. Notwithstanding the minimum limits set forth in this Contract for any type of insurance coverage, if Contractor maintains higher limits than the minimums shown above, the City requires and shall be entitled to coverage for the higher limits maintained by the Contractor. Any available insurance proceeds in excess of the specified minimum limits of insurance and coverage shall be available to the City.

I. **Form and Proof of Carriage of Insurance**

1. Any insurance carrier providing insurance coverage required by the Contract Documents shall be admitted to and authorized to do business in the State of California unless waived, in writing, by the City's Risk Manager. Carrier(s) shall have an A.M. Best rating of not less than an A:VII. Insurance deductibles or self-insured retentions must be declared by the Contractor. At the election of the City the Contractor shall either 1) reduce or eliminate such deductibles or self-insured retentions, or 2) procure a bond which guarantees payment of losses and related investigations, claims administration, and defense costs and expenses. If umbrella or excess liability coverage is used to meet any required limit(s) specified herein, the Contractor shall provide a "follow form" endorsement satisfactory to the City indicating that such coverage is subject to the same terms and conditions as the underlying liability policy.
2. Each insurance policy required by this Contract shall be endorsed to state that: (1) coverage shall not be suspended, voided, reduced or cancelled except after thirty (30) days prior written notice by certified mail, return receipt requested, has been given to the City; and (2) any failure to comply with reporting or other provisions of the policies, including breaches of warranties, shall not affect coverage provided to the City, its officials, officers, agents, employees, and volunteers.
3. The Certificates(s) and policies of insurance shall contain or shall be endorsed to contain the covenant of the insurance carrier(s) that it shall provide no less than thirty (30) days written notice be given to the City prior to any material modification or cancellation of such insurance. In the event of a material modification or cancellation of coverage, the City may terminate the Contract or stop the Work in accordance with the Contract Documents, unless the City receives, prior to such effective date, another properly executed original Certificate of Insurance and original copies of endorsements or certified original policies, including all endorsements and attachments thereto evidencing coverage's set forth herein and the insurance required herein is in full force and effect. Contractor shall not take

possession, or use the Site, or commence operations under this Contract until the City has been furnished original Certificate(s) of Insurance and certified original copies of endorsements or policies of insurance including all endorsements and any and all other attachments as required in this Article. The original endorsements for each policy and the Certificate of Insurance shall be signed by an individual authorized by the insurance carrier to do so on its behalf.

4. The Certificate(s) of Insurance, policies and endorsements shall so covenant and shall be construed as primary, and the City's insurance and/or deductibles and/or self-insured retentions or self-insured programs shall not be construed as contributory.
5. The City reserves the right to adjust the monetary limits and types of insurance coverages during the term of this Contract including any extension thereof if, in the City's reasonable judgment, the amount or type of insurance carried by the Contractor becomes inadequate.
6. Contractor shall report to the City, in addition to the Contractor's insurer, any and all insurance claims submitted by the Contractor in connection with the Work under this Contract.
7. Products/completed operations coverage shall extend a minimum of three years after the project completion. Coverage shall be included on behalf of the insured for covered claims arising out of the actions of independent contractors. If the insured is using subcontractors, the policy must include work performed "by or on behalf" of the insured. Policy shall contain no language that would invalidate or remove the insurer's duty to defend or indemnify for claims or suits expressly excluded from coverage. Policy shall specifically provide for a duty to defend on the part of the insurer. The City, its officers, officials, agents, employees, and volunteers shall be included as insureds under the policy.

## **5-7 Safety**

### **5-7.1 Work Site Safety**

New **Section 5-7.1.3 through 5-7.1.5** hereby are **added** to Section 5-7.1 of the Greenbook, as follows,

**5-7.1.3 Responsibility.** Contractor shall be solely responsible for all safety precautions and programs in connection with the Work. Such responsibility does not relieve Subcontractors of their responsibility for the safety of persons or property in the performance of their work, nor for compliance with applicable safety laws. Contractor shall comply with all Applicable Laws relating to the safety of persons or property, or to the protection of persons or property from damage, injury, or loss; and shall erect and maintain all necessary safeguards for such safety and protection. Contractor shall notify owners of adjacent property and of Underground Facilities and other utility owners when prosecution of the

Work may affect them, and shall cooperate with them in the protection, removal, relocation, and replacement of their property.

**5-7.1.4 Emergency.** The Contractor shall maintain emergency first aid treatment for his employees which complies with the Federal Occupational Safety and Health Act of 1970 (29 U.S.C. § 651 *et seq.*), and California Code of Regulations, Title 8, Industrial Relations Division 1, Department of Industrial Relations, Chapter 4. The Contractor shall ensure the availability of emergency medical services for its employees in accordance with California Code of Regulations, Title 8, Section 1512. The Contractor shall submit an Illness and Injury Prevention Program and a Project Site specific safety program to the City prior to beginning Work.

In emergencies affecting the safety or protection of persons or the Work or Property at the Site or adjacent thereto, the Contractor, without special instruction or authorization from the City or the Engineer, is obligated to act to prevent threatened damage, injury or loss. The Contractor shall give the Engineer prompt written notice if the Contractor believes that any significant changes in the Work or variations from the Contract Documents have been caused thereby.

**5-7.1.5 Hazard Communication Programs.** Contractor shall be responsible for coordinating any exchange of material safety data sheets or other hazard communication information required to be made available to or exchanged between or among employers at the Site in accordance with Applicable Laws.

#### **5-7.4 Hazardous Substances**

New **Section 5-7.4.1 through 5-7.4.4** hereby are **added** to Section 5-7.4 of the Greenbook, as follows,

**5-7.4.1 Hazardous Waste.** The City shall not be responsible for any Hazardous Waste brought to the site by the Contractor. If the Contractor: (i) introduces and/or discharges a Hazardous Waste onto the site in a manner not specified by the Contract Documents; and/or (ii) disturbs a Hazardous Material identified in the Contract Documents, the Contractor shall hire a qualified remediation contractor at Contractor's sole cost to eliminate the condition as soon as possible. Under no circumstance shall the Contractor perform Work for which it is not qualified. The City, in its sole discretion, may require the Contractor to retain at Contractor's cost an independent testing laboratory.

**5-7.4.2 Encounter.** If the Contractor encounters a Hazardous Waste which may cause foreseeable injury or damage, Contractor shall immediately: (i) secure or otherwise isolate such condition; (ii) stop all Work in connection with such material or substance (except in an emergency situation); and (iii) notify the City (and promptly thereafter confirm such notice in writing).

**5-7.4.3 Exposure.** Subject to Contractor's compliance with Section 5-7.4.2, the City shall verify the presence or absence of the Hazardous Waste reported by the Contractor, except as qualified under Section 5-7.4.1 and Section 5-7.4.2 in the event such material or substance is found to be present, verify that the levels of the hazardous material are below OSHA Permissible Exposure Levels and below levels which would classify the material as a state of California or federal hazardous waste. When the material falls below such levels, Work in the affected area shall resume upon direction by the City.

**5-7.4.4 Indemnification.** Contractor shall indemnify and hold harmless the City from and against claims, damages, losses, and expenses, arising from a Hazardous Waste on the Project Site, if such Hazardous Waste exceeded OSHA Permissible Exposure Levels or levels which would classify the material as a state of California or federal hazardous waste, and was either i) shown on the Contract Documents or information available to bidders; or (ii) brought to the site by Contractor. Nothing in this paragraph shall obligate the Contractor to indemnify the City in the event of the sole or active negligence or willful misconduct of the City, its officers, agents, or employees.

A new **Section 5-7.9** hereby is **added** to Section 5-7 of the Greenbook, as follows,

**5-7.9 Traffic Control.** Traffic control plans shall be prepared at Contractor's expense. Traffic control shall be performed at Contractor's expense in accordance with the requirements of the City and/or the local agency with jurisdiction. Costs for traffic control plans, implementation of traffic control, or traffic signal services required by the City shall be included in the Contractor's Bid. The City may, depending on the complexity of the project, require traffic control plans to be prepared by a California licensed traffic engineer or civil engineer. Said requirement will be identified in the Special Provisions.

All warning signs and safety devices used by the Contractor to perform the Work shall conform to the requirements contained in the State of California, Department of Transportation's current edition of "Manual of Traffic Controls for Construction and Maintenance Work Zones" or to the requirements of the local agency. The Contractor shall also be responsible for all traffic control required by the agency having jurisdiction over the Project on the intersecting streets. Contractor must submit a traffic control plan to the agency having jurisdiction over the Project for approval prior to starting Work.

The Contractor's representative on the site responsible for traffic control shall produce evidence that he/she has completed training acceptable to the California Department of Transportation for safety through construction zones. All of the streets in which the Work will occur shall remain open to traffic and one lane of traffic maintained at all times unless otherwise directed by the agency of jurisdiction. Businesses and residences adjacent to the Work shall be notified forty-eight (48) hours in advance of closing of driveways. The Contractor shall make every effort to minimize the amount of public parking temporarily eliminated due to construction in areas fronting businesses. No stockpiles of

pipe or other material will be allowed in traveled right-of-ways after working hours unless otherwise approved by the Engineer.

**Section 5-8** of the Greenbook is **added** to read as follows:

## **5-8 On-Site Responsibilities**

### **5-8.1 Environmental Quality Protection.**

- A. The Contractor shall comply with all requirements of applicable federal, state, and local environmental rules and regulations. Any infractions of said rules and regulations by the Contractor during the term of the Contract, which result in penalties, will be the responsibility of the Contractor. The City operates under a number of environmental permits issued by various agencies. If due to an action, inaction, or negligence by the Contractor, the City becomes subject to non-compliance penalties, the cost of such penalties shall be borne by the Contractor.
- B. The Contractor shall exercise care to preserve the natural landscape and vegetation and shall conduct operations so as to prevent unnecessary destruction, scarring, or defacing of the natural surroundings in the vicinity of the Work. Movement of crews and equipment within the rights-of-way and over routes provided for access to the Work shall be performed in a manner to prevent damage to property. When no longer required, construction roads shall be restored to original contours. Upon completion of the Work, and following removal of construction facilities and required cleanup, land used for construction purposes and not required for the completed installation shall be scarified and regraded, as required, so that all surfaces are left in a condition that will facilitate natural revegetation, provide for proper drainage, and prevent erosion.
- C. If, in the performance of the Work, evidence of the possible occurrence of any Federally listed threatened or endangered plant or animal is discovered, the Contractor shall notify the City Representative immediately, giving the location and nature of the findings. Written confirmation of the evidence, location and nature of the findings shall be forwarded to City within two (2) Days. The Contractor shall immediately cease all construction activities in the immediate area of the discovery to the extent necessary to protect the endangered plant or animal. If directed by the City Representative, Contractor will refrain from working in the immediate area, suspend the Work in its entirety, or alter its performance to ensure full compliance with all applicable permits, laws and regulations. Any City directed changes to the Work as a result of a siting will be pursuant to the Contract Documents. Any costs or delays incurred by City or the Contractor due to unreasonable or false notification of an endangered plant or animal will be borne by the Contractor.
- D. If, in the performance of the Work, Contractor should unearth cultural resources (for example, human remains, animal bones, stone tools, artifacts and/or midden deposits) through excavation, grading, watering or other means, the Contractor shall notify the construction/archeological monitor and/or the

City Representative immediately, giving the location and nature of the findings. Written confirmation of the evidence, location and nature of the findings shall be forwarded to the construction/archeological monitor and/or City within two (2) Days. The Contractor shall immediately cease all construction activities in the immediate area of the discovery to the extent necessary to protect the cultural resource. If directed by the City Representative, Contractor will refrain from working in the immediate area, suspend the Work in its entirety, or re-sequence and/or alter its performance to ensure full compliance with all applicable permits, laws and regulations. Should the presence of cultural resources be confirmed, the Contractor will assist the City Representative and the construction/archeological monitor in the preparation and implementation of a data recovery plan. The Contractor shall provide such cooperation and assistance as may be necessary to preserve the cultural resources for removal or other disposition. Any City directed changes to the Work as a result of the cultural resource will be pursuant to the Contract Documents. Should Contractor, without permission, injure, destroy, excavate, appropriate, or remove any cultural resource on or adjacent to the Site, it will be subject to disciplinary action, arrest, and penalty under applicable law. The Contractor shall be principally responsible for all costs of mitigation and/or restoration of cultural resources related to the unauthorized actions identified above. Contractor shall be required to pay for unauthorized damage and mitigation costs to cultural resources (historical and archeological resources) as a result of unauthorized activities that damage cultural resources and shall indemnify City pursuant to the Contract Documents.

**5-8.2 Diversion of Recyclable Waste Material.** In compliance with the applicable City's waste reduction and recycling efforts, Contractor shall divert all Recyclable Waste Materials to appropriate recycling centers as required for compliance with the local jurisdiction's waste diversion ordinances. Contractor will be required to submit weight tickets and written proof of diversion with its monthly progress payment requests. Contractor shall complete and execute any certification forms required by the City or other applicable agencies to document Contractor's compliance with these diversion requirements. All costs incurred for these waste diversion efforts shall be the responsibility of the Contractor.

**5-8.3 Inspector's Field Office.** If required by the City, the Contractor shall be responsible for providing the inspector's field office. The office shall be a substantial waterproof construction with adequate natural light and ventilation by means of stock design windows. Door shall have a key type lock or padlock clasp. The office shall have heating and air conditioning and shall be equipped with a telephone, a telephone answering machine, an ability to connect to the internet, and a fax machine at Contractor's expense. The field office shall be provided within 20 Days of the Notice to Proceed.

A table satisfactory for the study of plans and two chairs shall be provided by Contractor. Contractor shall provide and pay for adequate electric lights, local telephone service, and adequate heat and air conditioning for the field office until authorized removal.

**5-8.4 Contractor's Supervision.** Contractor shall continuously keep at the Project site, a competent and experienced full-time Project superintendent acceptable to the City. Superintendent must be able to proficiently speak, read, and write in English and shall have the authority to make decisions on behalf of the Contractor. Contractor shall continuously provide efficient supervision of the Project.

**5-8.5 Workers.** Contractor shall at all times enforce strict discipline and good order among its employees. Contractor shall not employ on the Project any unfit person or any one not skilled in the Work assigned to him or her.

Any person in the employ of the Contractor whom the City may deem incompetent or unfit shall be dismissed from the Work and shall not be employed on this Project.

**Section 5-9** of the Greenbook is **added** to read as follows:

## **5-9 Miscellaneous**

**5-9.1 Taxes:** Bidder shall include all applicable taxes in the amount bid, including, but not limited to, State Sales Tax, Federal Excise Tax, and any other applicable taxes collected by the City and/or County.

The Agency is exempt from the Federal Excise Tax and exception certificates may be furnished upon request. In certain instances, the bidder and subcontractor may be liable for Federal Excise Tax. Bidder must determine whether Federal Excise Tax is chargeable to him and, if so, the amount of the tax should be included in the amount bid.

Any new or additional taxes levied after the adoption of these specifications that are payable by the Agency are not to be included in the price bid but added thereto when invoiced.

Contractor shall pay all sales, consumer, use, and other similar taxes required to be paid in accordance with the Applicable Laws of the place of the Project which are applicable during the performance of the Work. In accordance with Revenue and Taxation Code section 107.6, the Contract Documents may create a possessory interest subject to personal property taxation for which Contractor will be responsible.

**5-9.2 Responsibility for Damage:** The Agency, the Board and the Engineer shall not be answerable or accountable in any manner for any loss or damage that may happen to the work or any part thereof; or for any materials or equipment used in performing the work; or for injury or damage to person or persons, either workmen or the public; or for damage to adjoining property from any cause whatsoever during the progress of the work or at any time before final acceptance.

The Contractor shall be held responsible for any and all loss, accidents, injury or damage to persons or property which may be the result of this contract and for which the Agency might be held liable. The Contractor shall protect and indemnify the Agency and save it harmless in every way from all claims, suits, or acts of law for damage or injury to persons or property that may arise or be

occasioned in any way because of this contract. The Board may retain so much of the money due the Contractor as shall be considered necessary, until disposition has been made of such suits or claims for damages as aforesaid.

- 5-9.3 Contractor's Responsibility for Work:** Until the formal acceptance of the work by the Engineer as evidenced in writing, the Contractor shall have the charge and care thereof except as provided in § 7-2.2.2 and shall bear the risk of injury or damage to any part thereof by the action of the elements or from any other cause, whether arising from the execution or from the nonexecution of the work. The Contractor shall rebuild, repair, restore and make good at its own expense all injuries or damages to any portion of the work occasioned by any cause before its completion and final acceptance and shall bear the expense thereof, except such injuries or damages as occasioned by acts of war. In the event of damage proximately caused by an Act of God, as defined by Section 7105 of the Public Contract Code, the City will pay for repair or restoration to damaged Work in excess of 5% of the total Bid.
- 5-9.4 Correction for Errors, Recovery for Errors, Dishonesty or Collusion:** The Agency reserves the right to correct any error that may have been made in any estimate that has been paid. The Agency also reserves the right to claim and recover by process of law, any sums sufficient to correct any error or make good any deficiency in the work resulting from such error or from dishonesty or collusion between any of the parties or individuals having dealings pursuant to the construction of the work, regardless of when such error, dishonesty or collusion shall be discovered.
- 5-9.5 Rights in Materials and Salvage:** Ownership of material incorporated in the work is vested in the name of the Agency. Any material delivered and paid for in part by the Agency or any material furnished by the Agency to be incorporated in the work, is or becomes the property of the Agency. Any salvageable materials or installations existing at the site of the work (such as manhole rings and covers, catch basin gratings, angle iron, pipe railings, valve boxes and lamp pole boxes, and other steel, cast iron or metallic materials; this does not include demolition items outlined per project specifications) that are the property of the Agency if they are to be removed shall be delivered F.O.B. the storage yard designated by the Agency. The salvageable materials shall be cleaned of clinging concrete and debris and delivered to the storage yard in the same condition as it existed prior to removal unless the Contractor is instructed otherwise by the Engineer.
- 5-9.6 Patents.** Contractor shall hold and save the City, officials, officers, employees, and authorized volunteers harmless from liability of any nature or kind of claim therefrom including costs and expenses for or on account of any patented or unpatented invention, article or appliance manufactured, furnished, or used by Contractor in the performance of this Contract.
- 5-9.7 Document Retention & Examination.** In accordance with Government Code section 8546.7, records of both the City and the Contractor shall be subject to examination and audit by the State Auditor General for a period of three (3) years after final payment.

Contractor shall make available to the City any of the Contractor's other documents related to the Project immediately upon request of the City.

In addition to the State Auditor rights above, the City shall have the right to examine and audit all books, estimates, records, contracts, documents, bid documents, subcontracts, and other data of the Contractor (including computations and projections) related to negotiating, pricing, or performing the modification in order to evaluate the accuracy and completeness of the cost or pricing data at no additional cost to the City, for a period of four (4) years after final payment.

- 5-9.8 Notice.** All notices shall be in writing and either served by personal delivery or mailed to the other party. Written notice to the Contractor shall be addressed to Contractor's principal place of business unless Contractor designates another address in writing for service of notice. Notice to the City shall be addressed to the City as designated in the Notice Inviting Bids unless the City designates another address in writing for service of notice. Notice shall be effective upon receipt or five (5) Days after being sent by first class mail, whichever is earlier. Notice given by facsimile shall not be effective unless acknowledged in writing by the receiving party.
- 5-9.9 Notice of Third Party Claims.** Pursuant to Public Contract Code section 9201, the City shall provide the Contractor with timely notification of the receipt of any third-party claims relating to the Contract. The City is entitled to recover reasonable costs incurred in providing such notification.
- 5-9.10 State License Board Notice.** Contractors are required by law to be licensed and regulated by the Contractors' State License Board which has jurisdiction to investigate complaints against contractors if a complaint regarding a patent act or omission is filed within four (4) years of the date of the alleged violation. A complaint regarding a latent act or omission pertaining to structural defects must be filed within ten (10) years of the date of the alleged violation. Any questions concerning a contractor may be referred to the Registrar, Contractors' State License Board, P.O. Box 26000, Sacramento, California 95826.
- 5-9.11 Assignment of Contract.** Contractor shall not assign, transfer, convey, sublet or otherwise dispose of the rights or title of interest of any or all of this contract without the prior written consent of the City. Any assignment or change of Contractor's name of legal entity without the written consent of the City shall be void. Any assignment of money due or to become due under this Contract shall be subject to a prior lien for services rendered or material supplied for performance of Work called for under the Contract Documents in favor of all persons, firms, or corporations rendering such services or supplying such materials to the extent that claims are filed pursuant to the Civil Code, the Code of Civil Procedure or the Government Code.
- 5-9.12 Change in Name and Nature of Contractor's Legal Entity.** Should a change be contemplated in the name or nature of the Contractor's legal entity, the Contractor shall first notify the City in order that proper steps may be taken to have the change reflected on the Contract and all related documents. No change

of Contractor's name or nature will affect the City's rights under the Contract, including but not limited to the bonds.

- 5-9.13 Prohibited Interests.** No City official or representative who is authorized in such capacity and on behalf of City to negotiate, supervise, make, accept, or approve, or to take part in negotiating, supervising, making, accepting, or approving any engineering, inspection, construction or material supply contract or any subcontract in connection with construction of the project, shall be or become directly or indirectly interested financially in the Contract.
- 5-9.14 Controlling Law.** Notwithstanding any subcontract or other contract with any subcontractor, supplier, or other person or organization performing any part of the Work, this Contract shall be governed by the law of the State of California excluding any choice of law provisions.
- 5-9.15 Jurisdiction; Venue.** Contractor and any subcontractor, supplier, or other person or organization performing any part of the Work agrees that any action or suits at law or in equity arising out of or related to the bidding, award, or performance of the Work shall be maintained in the Superior Court of San Bernardino County, California, and expressly consent to the jurisdiction of said court, regardless of residence or domicile, and agree that said court shall be a proper venue for any such action.
- 5-9.16 Cumulative Remedies.** The duties and obligations imposed by these General Conditions and the rights and remedies available hereunder to the parties hereto are in addition to, and are not to be construed in any way as a limitation of, any rights and remedies available to any or all of them which are otherwise imposed or available by Applicable Laws, by special warranty or guarantee, or by other provisions of the Contract Documents. The provisions of this Article will be as effective as if repeated specifically in the Contract Documents in connection with each particular duty, obligation, right, and remedy to which they apply.
- 5-9.17 Survival of Obligations.** All representations, indemnifications, warranties, and guarantees made in, required by, or given in accordance with the Contract Documents, as well as all continuing obligations indicated in the Contract Documents, will survive final payment, completion, and acceptance of the Work or termination or completion of the Contract or termination of the services of Contractor.
- 5-9.18 Headings.** Section and paragraph headings are inserted for convenience only and do not constitute parts of these General Conditions.
- 5-9.19 Assignment of Antitrust Actions.** In accordance with §7103.5(b) of the California Public Contract Code, Contractor and Subcontractors must conform to the following requirements:
1. In entering into a public works contract or a subcontract to supply goods, services, or materials pursuant to a public works contract, Contractor or Subcontractor offer and agree to assign to the awarding body all rights, title, and interest in and to all causes of action it may have under §4 of the Clayton

Act (15 U.S.C. Sec. 15) or under the Cartwright Act (Chapter 2 (commencing with §16700) of Part 2 of Division 7 of the Business and Professions Code) arising from purchases of goods, services, or materials pursuant to the public works contract or the subcontract.

2. This assignment must be made and become effective at the time the awarding body tenders to Contractor, without further acknowledgment by the parties.

**5-9.20 All Legal Provisions Included.**

- A. Contractor shall give all notices and comply with all federal, state, and local laws, ordinances, rules, and regulations bearing on conduct of work as indicated and specified by their terms. References to specific laws, rules or regulations in this Contract are for reference purposes only, and shall not limit or affect the applicability of provisions not specifically mentioned. If Contractor observes that drawings and specifications are at variance therewith, he shall promptly notify City in writing and any necessary changes shall be adjusted as provided for in this Contract for changes in Work. If Contractor performs any Work knowing it to be contrary to such laws, ordinances, rules, and regulations, and without such notice to City, he shall bear all costs arising therefrom.
- B. Contractor shall be responsible for familiarity with the Americans with Disabilities Act ("ADA") (42 U.S.C. § 12101 et seq.). The Work will be performed in compliance with ADA laws, rules, and regulations. Contractor shall comply with the Historic Building Code, including, but not limited to, as it relates to the ADA, whenever applicable.
- C. Contractor acknowledges and understands that, pursuant to Public Contract Code section 20676, sellers of "mined material" must be on an approved list of sellers published pursuant to Public Resources Code section 2717(b) in order to supply mined material for this Contract.
- D. No City official or representative who is authorized in such capacity and on behalf of City to negotiate, supervise, make, accept, or approve, or to take part in negotiating, supervising, making, accepting, or approving any engineering, inspection, construction or material supply contract or any subcontract in connection with construction of the Work, shall be or become directly or indirectly interested financially in the Contract.
- E. All provisions of law required to be inserted in the Contract or Contract Documents pursuant to any Applicable Laws shall be and are inserted herein. If through mistake, neglect, oversight, or otherwise, any such provision is not herein inserted or inserted in improper form, upon the application of either party, the Contract or Contract Documents shall be changed by City, at no increase in Contract Price or extension in Contract Times, so as to strictly comply with the Applicable Laws and without prejudice to the rights of either party hereunder.

## SECTION 6 PROSECUTION AND PROGRESS OF THE WORK

A new **Section 6-0** is added to the Greenbook, as follows,

**6-0 Contractor's Means and Methods.** Contractor is solely responsible for the means and methods utilized to perform the Work. In no case shall the Contractor's means and methods deviate from commonly used industry standards.

**6-1 Construction Schedule and Commencement of the Work.**

**6-1.1 Construction Schedule.**

New **Section 6-1.1.1 through 6-1.1.6** are added to the Greenbook, as follows,

**6-1.1.1 General Requirements.** The schedule shall be prepared in a Critical Path Method ("CPM") format and in an electronic scheduling program acceptable to the City and as specified in the Contract Documents. Contractor shall deliver the schedule and all updates to the City in both paper and electronic form. The electronic versions shall be in the format and include all data used to prepare the schedule. Copies are not acceptable.

**6-1.1.2 Schedule.** The receipt or approval of any schedules by the City shall not in any way relieve the Contractor of its obligations under the Contract Documents. The Contractor is fully responsible to determine and provide for any and all staffing and resources at levels which allow for good quality and timely completion of the Project. Contractor's failure to incorporate all elements of Work required for the performance of the Contract or any inaccuracy in the schedule shall not excuse the Contractor from performing all Work required for a completed Project within the specified Contract Time. If the required schedule is not received by the time the first payment under the Contract is due, Contractor shall not be paid until the schedule is received, reviewed, and accepted by the City.

**6-1.1.3 Schedule Contents.** The schedule shall allow enough time for inclement weather. The schedule shall indicate the beginning and completion dates of all phases of construction; critical path for all critical, sequential time related activities; and "float time" for all "slack" or "gaps" in the non-critical activities. The schedule shall include appropriate time allowances and constraints for submittals, items of interface with Work performed by others, and specified construction, start-up and performance tests. All float shall be owned by the Project. Schedules indicating early or late completion shall not modify or have any effect on the Contract Time, regardless of whether the schedules are reviewed and/or accepted by the City. For purposes of determining Liquidated Damages, the Contract Time shall control and may only be altered by a duly authorized Change Order.

**6-1.1.4 Schedule Updates.** Contractor shall continuously update its construction schedule. Contractor shall submit an updated and accurate construction schedule to the City: (1) prior to the start of construction, if there are any changes to the initial schedule; (2) with each progress payment request; and (3) whenever requested to do so by the City. The City may withhold progress payments or other amounts due under the Contract Documents if Contractor fails to submit an updated and accurate construction schedule. Upon the City's request, Contractor shall submit any schedules or updates to the City in the native electronic format of the software used to create the schedule. Contractor shall also submit schedules showing a two-week detailed look-ahead at weekly meetings conducted with the City. The two-week look-ahead schedule shall clearly identify all staffing and other resources which in the Contractor's judgment are needed to complete the Work within the Contract Time, and it shall clearly state the number of staff to be used on each daily segment of the Work.

**6-1.1.5 Acceptance.** Acceptance of the schedules by the City will not impose on responsibility for accuracy, for sequencing, scheduling, or progress of the Work, or compliance with the Contract Documents. Acceptance will not interfere with or relieve Contractor from Contractor's full responsibility therefor.

**6-1.1.6 Recovery Schedule.**

1. Should any of the following conditions exist, City may require Contractor to prepare, at no extra cost to City, a plan of action and a recovery schedule for completing the Work and achieving all contractual milestones within the allotted Contract Time:
  - a. The Contractor's monthly progress report indicates delays that are, in the opinion of City, of sufficient magnitude that City questions the Contractor's ability to complete the Work;
  - b. The schedule shows the Contractor to be thirty (30) or more days behind the critical path at any time during construction;
  - c. The Contractor desires to make changes in the logic or the planned duration of future activities of the schedule which, in the opinion of City, are major in nature.
2. The recovery schedule shall include proposed revisions to the Construction Schedule, demonstrating how Contractor intends to achieve all contractual milestones including Contract completion within the allotted Contract Time. The submittal shall include a narrative describing the actions planned by the Contractor to recover the schedule.
3. Contractor shall submit the Recovery Schedule within seven (7) Days of City's request. If Contractor asserts that City is responsible for the

delay, failure to submit the recovery schedule within seven (7) Days of City's request, will be considered a concurrent delay event attributable to Contractor, and Contractor shall only be entitled to non-compensable adjustments to Contract Times. If Contractor is responsible for the delay, this provision will not limit or affect Contractor's liability and failure to submit the recovery schedule with seven (7) Days of City's request may result in City withholding progress payments or other amounts due under the Contract Documents.

4. Contractor is responsible for all costs associated with the preparation and execution of the recovery schedule, including any necessary recovery actions, which may include, but are not limited to, assignment of additional labor, and/or equipment, shift or overtime work, expediting of submittals or deliveries, overlapping of activities or sequencing changes to increase activity concurrence. Regardless of whether City directs Contractor to prepare a recovery schedule pursuant to this Section, Contractor shall promptly undertake appropriate action at no additional cost to City to recover the schedule whenever the current construction schedule shows that the Contractor will not achieve a milestone and/or complete the Work within the allotted Contract Time.

A new **Section 6-1.3** is **added** to the Greenbook, as follows,

**6-1.3 Working Hours.** Working hours shall be limited to 7:00 a.m. and 3:30 p.m. unless otherwise authorized, in writing, by the Engineer.

### **6-3 Time of Completion.**

A new **Section 6-3.3** is **added** to the Greenbook, as follows,

**6-3.3 Time for Completion.** The time for completion set forth in Article 2 of the Contract for Construction shall commence: (1) on the date stated in the Notice to Proceed, or (2) if the Notice to Proceed does not specify a commencement date, then on the date of the Notice to Proceed and shall be completed by Contractor in the time specified in the Contract Documents. The City is under no obligation to consider early completion of the Project; and the Contract completion date shall not be amended by the City's receipt or acceptance of the Contractor's proposed earlier completion date. Any difference in time between the Contractor's early completion and the Contract Time shall be considered a part of the Project float. Contractor shall not be entitled to compensation, and the City will not compensate Contractor, for delays which impact early completion. Contractor shall not, under any circumstances, receive additional compensation from the City (including but not limited to indirect, general, administrative, or other forms of overhead costs) for the period between the time of earlier completion proposed by the Contractor and the Contract completion date.

### **6-4 Delays and Extension of Time.**

## **6-4.2 Extensions of Time**

**Section 6-4.2** of the Greenbook shall be **amended** to include the following:

Contractor's entitlement to an extension of the Contract Time is limited to a City-caused extension of the critical path, reduced by the Contractor's concurrent delays, and established by a proper time impact analysis. Contractor shall not be charged liquidated damages because of any delays in completion of the Work due to unforeseeable causes beyond the control and without the fault or negligence of Contractor (or its Subcontractors or Suppliers). The City shall ascertain the facts and extent of delay and grant extension of time for completing the Work when, in its judgment, the facts justify such an extension. Contractor shall not be entitled to an adjustment in the Contract Times for delays within the control of Contractor. Delays attributable to and within the control of a Subcontractor or Supplier shall be deemed to be delays within the control of Contractor.

Contractor shall abide by the Engineer's determination of what constitutes inclement weather. Time extensions for inclement weather shall only be granted when the Work stopped during inclement weather is on the critical path of the Project schedule. Contractor shall not be entitled to reverse liquidated damages for time extensions resulting from inclement weather.

## **6-5 Use of Improvement During Construction.**

**Section 6-5** of the Greenbook shall be **amended** to include the following:

The City reserves the right to occupy or utilize any portion of the Work at any time before completion, and such occupancy or use shall not constitute acceptance of any part of Work covered by this Contract. This use shall not relieve the Contractor of its responsibilities under the Contract.

## **6-6 Suspension of the Work.**

**Section 6-6.1** shall be **amended** to read as follows,

### **6-6.1 General.**

1. The City may, at its sole option, decide to suspend at any time the performance of all or any portion of the Work by notice in writing to Contractor. Such notice of suspension of Work will designate the amount and type of plant, labor, and equipment to be committed to the Project during the period of suspension. Contractor shall use its best efforts to utilize its plant, labor, and equipment in such a manner as to minimize costs associated with suspension.

2. Upon receipt of any such notice, Contractor shall, unless the notice requires otherwise:
  - a. Immediately discontinue Work on the date and to the extent specified in the notice;
  - b. Place no further orders or subcontracts for material, services, or facilities with respect to suspended Work other than to the extent required in the notice;
  - c. Promptly make every reasonable effort to obtain suspension upon terms satisfactory to the City's Representative of all orders, subcontracts, and rental agreements to the extent they relate to performance of Work suspended; and
  - d. Continue to protect and maintain the Work including those portions on which Work has been suspended.
3. Except as provided by this Section, as full and complete compensation for such suspension, Contractor shall be granted an adjustment in the Contract Price based on a negotiated daily rate that reflects the Contractor's actual costs associated with the demobilized condition of the Site and an extension of the Contract Times equal to the number of days performance of Work is suspended; provided, however, that no adjustment of Contract Price or extension of Contract Times shall be granted if the suspension results from Contractor's non-compliance with the requirements of the Contract.

## **6-7 Termination of the Contract for Default.**

**Section 6-7.1** shall be **amended** to read as follows,

### **6-7.1 General.**

1. In the sole estimation of the City, if the Contractor:
  - a) refuses or fails to prosecute the Work or any separable part thereof with such diligence as will insure its completion within the time specified by the Contract Documents, or any extension thereof,
  - b) fails to prosecute the Work according to the schedule approved by the Engineer,
  - c) if the Contractor should be adjudged a bankrupt, make a general assignment for the benefit of its creditors, or if a receiver should be appointed on account of its insolvency,
  - d) the Contractor or any of its subcontractors should violate any of the provisions of this Contract,
  - e) abandons the Work by failing to report to the Work site and diligently prosecute the Work to completion,

- f) disregards written instructions from the Engineer or materially violates provisions of the Contract Documents,
- g) disregards laws or regulations of any public body having jurisdiction, or
- h) commits continuous or repeated violations of regulatory or statutory safety requirements,

then the Agency will consider the Contractor in default of the Contract. The City may serve written notice upon the Contractor and its surety of the City's intention to terminate this Contract. This notice of intent to terminate shall contain the reasons for such intention to terminate this Contract, and a statement to the effect that the Contractor's right to perform this Contract shall cease and terminate upon the expiration of ten (10) Days unless such violations have ceased and arrangements satisfactory to the City have been made for correction of said violations.

2. After expiration of the ten (10) Day period, the City may terminate the Contract by providing a Notice of Termination to the Contractor. The City may take over and complete the Work by any method it may deem appropriate, including enforcement of the Project performance bond. Contractor and its surety shall be liable to the City for any excess costs or other damages incurred by the City to complete the Work. If the City takes over the Work, the City may, without liability for so doing, take possession of and utilize in completing the Work such materials, appliances, plant, and other property belonging to the Contractor as may be on the Site.
  
3. Upon termination, Contractor shall not be entitled to receive any further payment from the City, except for Work which was duly performed prior to the effective date of the Notice of Termination. Contractor shall submit an invoice for final payment within thirty (30) Days of the effective date of the Notice of Termination. The City may withhold from final payment up to 150% of any disputed amounts, including any amounts which may be necessary to repair defective Work, complete unfinished Work, or are otherwise occasioned by Contractor's failure to perform its duties under the Contract.

**6-8 Termination of the Contract for Convenience.**

**Section 6-8** shall be **amended** to read as follows,

1. The City may terminate performance of the Work called for by the Contract Documents in whole or, from time to time, in part, upon ten (10) Days written notice if the City determines that a termination is in the City's interest.

2. The Contractor shall terminate all or any part of the Work upon delivery to the Contractor of a Notice of Termination specifying that the termination is for the convenience of the City, the extent of termination, and the effective date of such termination.
3. After receipt of Notice of Termination, and except as directed by the City's Representative, the Contractor shall, regardless of any delay in determining or adjusting any amounts due under this termination for convenience clause, immediately proceed with the following obligations:
  - a. Stop Work as specified in the Notice.
  - b. Complete any Work specified in the Notice of Termination in a least cost/ shortest time manner while still maintaining the quality called for under the Contract Documents.
  - c. Leave the property upon which the Contractor was working and upon which the facility (or facilities) forming the basis of the Contract Document is situated in a safe and sanitary manner such that it does not pose any threat to the public health or safety.
  - d. Terminate all subcontracts to the extent that they relate to the portions of the Work terminated.
  - e. Place no further subcontracts or orders, except as necessary to complete the continued portion of the Contract.
  - f. Submit to the City's Representative, within ten (10) Days from the effective date of the Notice of Termination, all of the usual documentation called for by the Contract Documents to substantiate all costs incurred by the Contractor for labor, materials and equipment through the effective date of the Notice of Termination. Any documentation substantiating costs incurred by the Contractor solely as a result of the City's exercise of its right to terminate this Contract pursuant to this clause, which costs the contractor is authorized under the Contract documents to incur, shall: (1) be submitted to and received by the Engineer no later than 30 Days after the effective date of the Notice of Termination; (2) describe the costs incurred with particularity; and (3) be conspicuously identified as "Termination Costs occasioned by the City's Termination for Convenience." If the City rejects any costs, Contractor shall be deemed to waive the rejected costs unless Contractor files a Claim within thirty (30) Days of the rejection pursuant to Section 6-14.
  - g. Contractor shall be entitled to receive only the amounts payable under this Section, and Contractor specifically waives any claim for any other amounts or damages, including, but not limited to, any claim for consequential damages or lost profits. The provisions in this Section are in addition to and not in limitation of any other rights or remedies available to the City.
4. Termination of the Contract shall not relieve surety of its obligation for any just claims arising out of or relating to the Work performed.

5. Notwithstanding any other provision of this Section, when immediate action is necessary to protect life and safety or to reduce significant exposure or liability, the City may immediately order Contractor to cease Work on the Project until such safety or liability issues are addressed to the satisfaction of the City or the Contract is terminated.
6. If the City terminates Contractor for cause, and if it is later determined that the termination was wrongful, such default termination shall automatically be converted to and treated as a termination for convenience. In such event, Contractor shall be entitled to receive only the amounts payable under this section, and Contractor specifically waives any claim for any other amounts or damages, including, but not limited to, any claim for consequential damages or lost profits.

**Section 6-9** shall be **amended** to read as follows,

- 6-9 Liquidated Damages.** If the Work is not completed within the Contract Time(s), it is understood that the City will suffer damage. In accordance with Government Code section 53069.85 and Public Contract Code section 7102, being impractical and infeasible to determine the amount of actual damage, it is agreed that Contractor shall pay to the City as fixed and liquidated damages, and not as a penalty, the sum stipulated in the Contract for each calendar day of delay until the Work is fully completed. Contractor and its surety shall be liable for any liquidated damages. Any money due or to become due the Contractor may be retained to cover liquidated damages.

A new **Section 6-10** is **added** to the Greenbook, as follows,

- 6-10 Reverse Liquidated Damages.** Consistent with Public Contract Code Section 7102, Contractor will be compensated for damages incurred due to unreasonable delays to the critical path for which the City is responsible. The parties agree that determining Contractor's exact delay damages are and will continue to be impracticable and extremely difficult. As such, for each calendar day or working day in excess of the time for completion set forth in Article 2 of the Contract for Construction, the City shall pay to the Contractor the sum stipulated in the Contract per day. Such amount shall constitute the only payment allowed for any City-caused delays and shall necessarily include all overhead, all profits, all administrative costs, all bond costs, all labor, materials, equipment and rental costs and any other costs, expenses and fees incurred or sustained as a result of such delays. Contractor shall not be entitled to reverse liquidated damages for any change in the Work in which Contractor is compensated for overhead and profit through a change in Unit Price Work or a Change Order resulting in a lump sum or allowed mark-up for the additional Work. The amount of reverse liquidated damages shall be reduced by Contractor's concurrent delays.

The City's liability to Contractor for delays for which the City is responsible shall be limited to only an extension of time unless such delays were unreasonable under the circumstances. In no case shall the City be liable for any costs which are borne by the Contractor in the regular course of business, including, but not limited to, home office overhead and other ongoing costs. Damages caused by unreasonable City delay shall be based on actual costs only, no proportions or formulas shall be used to calculate any delay damages.

A new **Section 6-11** is **added** to the Greenbook, as follows,

**6-11 Force Majeure.** In accordance with 6-4.2 and 6-10, the Contractor shall not be charged liquidated damages, and the City shall not be responsible, for any delays resulting from a Force Majeure Event. If a delay to the critical path results from a Force Majeure Event, the Contractor will be entitled to a time extension but will not receive an adjustment to the Contract Price or any other compensation. Such a non-compensable adjustment shall be Contractor's sole and exclusive remedy for such delays.

A new **Section 6-12** is **added** to the Greenbook, as follows,

**6-12 Procedure for Time Extensions and Delay Damages.** Contractor shall not be entitled to any extension of time or any reverse liquidated damages unless Contractor properly notices the delay and adjustment to compensation and requests a Change Order in accordance with 6-13 Change Orders. Contractor's failure to timely and fully comply with the Change Order procedures in the Contract Documents shall constitute a waiver of Contractor's right to a time extension or reverse liquidated damages.

A new **Section 6-13** is **added** to the Greenbook, as follows,

**6-13 Change Orders.** All changes to the Contract, including compensation increases and time extensions, shall be through a written Change Order in accordance with this Section. The City, without invalidating the Contract, may order changes in the Work consisting of additions, deletions or other revisions, and Contractor's compensation and the time for completion shall be adjusted accordingly. Whenever any change is made as provided for herein, such change shall be considered and treated as though originally included in the Contract, and shall be subject to all terms, conditions, and provisions of the original Contract. Contractor shall not be entitled to claim or bring suit for damages, whether for loss of profits or otherwise, on account of any decrease or omission of any item or portion of Work to be done. No dispute, disagreement, or failure of the parties to reach agreement on the terms of the Change Order shall relieve the Contractor from the obligation to proceed with performance of the Work, including Additional Work, promptly and expeditiously. Any alterations, extensions of time, Additional Work, or any other changes may be made without securing consent of the Contractor's surety or sureties.

#### **6-13.1 Change in Contract Procedures.**

**6-13.1.1 City Directive.** The City may direct changes in the Work by delivering a written directive. To the extent the work directive results in a change to compensation or time, Contractor must timely request a Change Order and comply with all Change Order procedures in accordance with this Section. Notwithstanding issuance of a work directive, Contractor's failure to timely request a Change Order shall constitute a waiver by Contractor of any adjustment to compensation or time extension for Work performed under the directive. The City shall not be liable to Contractor for Work performed or omitted by Contractor in reliance on verbal orders.

**6-13.1.2 Contractor's Notice of Change/ Delay.** If Contractor intends to initiate a Change Order Request, then Contractor shall provide the City

with written notice of the underlying facts and circumstances that gave rise to the proposed change within the following times:

- a. If due to unknown subsurface or latent physical conditions, within three (3) days from the discovery date or prior to the alterations of the conditions, whichever is earlier.
- b. If due to a Force Majeure Event, as soon as reasonably practicable under the conditions, which shall be no longer than three (3) days from the date the Contractor discovers that the Force Majeure Event gives rise to a change, unless that the conditions are such that notice within three (3) days is not possible or practicable.
- c. If due to any other matter that may involve an adjustment to the Contract Time or the Contract Price, within seven (7) days from the discovery date.

To be considered valid and complete, the notice of change/delay shall include a general statement of the circumstances giving rise to the notice of change/delay and a reasonable order of magnitude estimate of the additional costs and/or time. If the circumstances give rise to both a cost adjustment and time extension, Contractor shall submit the notice of change and notice of delay concurrently.

**6-13.1.3 Request for Change in Compensation and/ or Extension of Time.**

Contractor shall submit a Change Order Request for any adjustment to Contractor's compensation and/or any extension of time. The Change Order Request shall be made prior to incurring any expense and within fourteen (14) Days from either Contractor's notice of change/delay or the City's directive ordering the change. The Change Order Request shall include all of the following information (unless inapplicable to the change):

- a. A detailed description of the circumstances giving rise to the request;
- b. A complete itemized cost proposal, including itemized pricing for first tier Subcontractors;
- c. Supporting documentation for all costs;
- d. A time impact analysis showing the impact of the delay to the critical path to completion;
- e. If any added costs or information cannot be determined at the time of the Change Order Request, the reason the costs or information cannot be determined at the time; and
- f. Certification to the accuracy of the Change Order Request under penalty of perjury.

The time impact analysis shall be in the critical path method format and shall show the sequencing of all critical and non-critical new activities and/or activity revisions affected by the delay, with logic ties to all affected existing activities noted on the schedule.

The City may demand, and Contractor shall provide, any additional information supporting the Change Order Request, including but not limited to native electronic format version of schedules and time impact analyses. Contractor shall provide the requested additional information within five (5) Days of the request.

For any costs or information that cannot be determined at the time Contractor submits the Change Order Request, Contractor shall submit to the City notice of the costs or information and all supporting documentation within five (5) Days of when the costs or other information become subject to determination.

**6-13.1.4 City's Final Decision on Change Order; Ordered Changes.** If the City denies the Change Order Request or disagrees with the proposal submitted by Contractor, it will notify the Contractor, and the City will provide its opinion of the appropriate price and/or time extension. If no agreement can be reached, the City shall have the right to order the Work performed on a time and materials basis or to issue a unilateral Change Order setting forth the City's determination of the reasonable additions or savings in costs and time attributable to the extra or deleted work. The City shall also have the right to order changes in the Work to be performed promptly by the Contractor on a time and materials basis or to issue a unilateral Change Order setting forth the City's determination of the reasonable additions or savings in costs and time attributable to the extra or deleted work. The City's determination shall become final and binding if the Contractor fails to submit a Claim in writing to the City within fourteen (14) Days of the issuance of the unilateral Change Order, disputing the terms of the unilateral Change Order and providing such supporting documentation for its position as the City may reasonably require.

**6-13.1.5 Contractor's Waiver of Further Relief.** CONTRACTOR'S FAILURE TO PROVIDE A COMPLETE AND TIMELY NOTICE OF CHANGE/DELAY AND/OR CHANGE ORDER REQUEST, OR TO COMPLY WITH ANY OTHER REQUIREMENT OF THIS SECTION, SHALL CONSTITUTE A WAIVER BY CONTRACTOR OF THE RIGHT TO A CONTRACT ADJUSTMENT ON ACCOUNT OF SUCH CIRCUMSTANCES AND A WAIVER OF ANY RIGHT TO FURTHER RECOURSE OR RECOVERY BY REASON OF OR RELATED TO SUCH CHANGE BY MEANS OF THE CLAIMS DISPUTE RESOLUTION PROCESS OR BY ANY OTHER LEGAL PROCESS OTHERWISE PROVIDED FOR UNDER APPLICABLE LAWS.

Contractor recognizes and acknowledges that timely submission of a formal written notice of change/delay and Change Order Request,

whether or not the circumstances of the change may be known to the City or available to the City through other means, is not a mere formality but is of crucial importance to the ability of the City to promptly identify, prioritize, evaluate and mitigate the potential effects of changes. Any form of informal notice, whether verbal or written (including, without limitation, statements in requests for information, statements in Submittals, statements at any job meeting or entries on monthly reports, daily logs or job meeting minutes), that does not strictly comply with the formal requirements of this Section, shall accordingly be insufficient.

#### **6-13.1.6 Change Order Format.**

- a. A Change Order signed by the Contractor indicates the Contractor's agreement therewith, including any adjustment in compensation or extension of time, and the full and final settlement of all costs (direct, indirect, and overhead) related to the Work authorized by the Change Order.
- b. The City may designate the forms to be used for notices, requests, and Change Orders. If so designated, Contractor may only use such forms. Contractor shall not reserve a right to assert impact costs, extended job site costs, extended overhead, constructive acceleration and/or actual acceleration beyond what is stated in the Change Order. No Claims shall be allowed for impact, extended overhead costs, constructive acceleration and/or actual acceleration due to a multiplicity of changes and/or clarifications. The Contractor may not change or modify the City's Change Order form in an attempt to reserve additional rights.

### **6-13.2 Determining Adjustments to Compensation.**

**6-13.2.1 Limitation on Costs.** Contractor shall not be entitled to any compensation for Work subject to a Change Order except as expressly set forth in this Section. The City Manager may approve Additional Work up to ten percent (10%) of the amount of the Agreement or fifty thousand dollars (\$50,000.00). In no event shall the total sum of the agreement (Contract Price and Additional Work) exceed fifty thousand dollars (\$50,000.00). Any additional work in excess of this amount shall be approved by the City Council. The mark-up added in instances of Additional Work shall constitute the entire amount of profit, any mark-ups, any field or home office overhead costs, including personnel, equipment or office space, any materials, or any costs of equipment idle time for such Work.

**6-13.2.2 Unit Price Change Orders.** When the actual quantity of a Unit Price Work item varies from the Bid Schedule, compensation for the change

in quantity will be calculated by multiplying the actual quantity by the unit price. This calculation may result in either an additive or deductive Change Order. Bid items included on the Bid Schedule may be deducted from the Work in their entirety without any negotiated extra costs. Because Unit Price Work includes overhead and profit as determined by Contractor at the time of its Bid submission, no mark up or deduction for overhead and profit will be allowed.

**6-13.2.3 Lump Sum Change Orders.** Whenever possible, any changes affecting compensation shall be in a lump sum mutually agreed by the Contractor and the City.

**6-13.2.4 Time and Materials Change Orders.** The City may direct the Contractor to proceed with the Additional Work with payment to be made on the basis of actual cost of the labor and materials required to complete the Additional Work. If the Project is federally funded, a time and materials Change Order shall only be issued after a determination that no other Change Order is suitable and the Change Order shall include a ceiling price that the Contractor exceeds at its own risk.

**6-13.2.5 Federally Funded Projects.** For any change in price to the Contract, general and administrative expenses shall be negotiated and must conform to the cost principles set forth under at 2 C.F.R. Part 200, subpart E, and profit shall be negotiated as a separate element of the cost. To establish a fair and reasonable profit, consideration must be given to the complexity of the Additional Work to be performed, the risk borne by the Contractor, the Contractor's investment, the amount of subcontracting, the quality of its record of past performance, and industry profit rates in the surrounding geographical area for similar work.

**6.13.2.6 Allowed Costs.** Estimates for lump sum quotations and accounting for time-and-material work shall be limited to direct expenditures necessitated specifically by the change and shall be segregated as follows:

- a. **Labor.** The costs of labor will be the actual cost for wages prevailing locally for each craft or type of worker at the time the Additional Work is done, plus employer payments of payroll taxes and insurance, health and welfare, pension, vacation, apprenticeship funds, and other direct costs resulting from federal, state, or local laws, as well as assessment or benefits required by lawful collective bargaining agreements. The use of a labor classification which would increase the Additional Work cost will not be permitted unless the Contractor establishes the necessity for such additional costs. Labor costs for equipment operators and helpers shall be reported only when such costs are not included in the invoice for equipment rental.

- b. **Materials.** The cost of materials reported shall be at the lowest current price at which such materials are locally available in the quantities involved, plus sales tax, freight and delivery. Materials costs shall be based upon supplier or manufacturer's invoice.
- c. **Tool and Equipment Use.** Regardless of ownership, the rates to be used in determining equipment use shall not exceed listed rates prevailing locally at equipment rental agencies, or distributors, at the time the work is performed. The Contractor shall furnish cost data supporting the establishment of the rental rate. The rental rate to be applied for use of each item of equipment shall be the rate resulting in the least total cost to the City for the total period of use. The City shall make the final determination as to an equitable rental rate for the equipment. No payment will be made for the use of small tools, which have a replacement value of \$1,000 or less.
  - (i) The rental time to be paid for equipment shall be the time the equipment is in productive operation on the Additional Work being performed. Rental time will not be allowed while equipment is inoperative due to breakdowns.
  - (ii) All equipment shall, in the opinion of the City, be in good working condition and suitable for the purpose for which the equipment is to be used. Equipment with no direct power unit shall be powered by a unit of at least the minimum rating recommended by the manufacturer.
  - (iii) Before construction equipment is used on any Additional Work, the Contractor shall plainly stencil or stamp an identifying number thereon at a conspicuous location, and shall furnish to the City, in duplicate, a description of the equipment and its identifying number.
  - (iv) When hourly rates are listed, any part of an hour less than 30 minutes of operation shall be considered to be 1/2-hour of operation, and any part of an hour greater than 30 minutes will be considered one hour of operation. When daily rates are listed, any part of a day less than 4 hours operation shall be considered to be 1/2-day of operation.
- d. **Allowed Mark-up.** The allowed mark-up for any and all overhead (including supervision and home and field office costs) and profit on work added to the Contract shall be determined in accordance with the following provisions:
  - (i) "Net Cost" is defined as the actual costs of labor, materials and tools and equipment only, excluding overhead and profit. The costs of applicable insurance and bond premium will be reimbursed to the Contractor and Subcontractors at cost only, without mark-up. Contractor shall provide the City with

documentation of the costs, including but not limited to payroll records, invoices, and such other information as the City may reasonably request.

- (ii) For Work performed by the Contractor's forces the allowed mark-up shall not exceed fifteen (15%) percent of labor costs, ten percent (10%) of material costs, and ten percent (10%) of the cost of tools and equipment use.
- (iii) For Work performed by a Subcontractor, the added cost for overhead and profit shall not exceed fifteen percent (15%) of the Subcontractor's Net Cost of the Work to which the Contractor may add up to five percent (5%) of the Subcontractor's Net Cost.
- (iv) For Work performed by a sub-subcontractor, the added cost for overhead and profit shall not exceed fifteen percent (15%) of the sub-subcontractor's Net Cost for Work to which the Subcontractor and Contractor may each add up to an additional five percent (5%) of the Net Cost of the lower tier subcontractor.
- (v) No additional mark-up will be allowed for lower tier subcontractors, and in no case shall the added cost for overhead and profit payable by the City exceed twenty-five percent (25%) of the Net Cost as defined herein, of the party that performs the Work.
- (vi) Calculation of the mark-up will be subject to the limitations above and to calculation as further detailed in (b)(B)(5) above.

**e. Documentation of Time-and-Material Costs.**

- (i) T&M Daily Sheets. Contractor must submit timesheets, materials invoices, records of equipment hours, and records of rental equipment hours to the City's for an approval signature each day that Work is performed on a time-and-material basis. The Engineer's signature on time sheets only serves as verification that the Work was performed and is not indicative of the City's agreement to Contractor's entitlement to the cost.
- (ii) T&M Summary Sheet. Contractor shall submit a T&M Summary Sheet, which shall include total actual costs, within five (5) Days following completion of Additional Work on a time-and-material basis. Contractor's total actual cost shall be presented in a summary table in an electronic spreadsheet file by labor, material, equipment, and any other costs, along with documentation supporting the costs. Contractor's failure to

submit the T&M Summary Sheet within five (5) Days of completion of the Additional Work will result in Contractor's waiver for any reimbursement of any costs associated with the Additional Work.

- f. **Excluded Costs.** The following costs or any other home or field office overhead costs, all of which are to be considered administrative costs covered by the Contractor's mark-up, shall not be allowed costs and shall not be included in any lump sum proposals or time-and-materials invoices:
- (i) **Overhead Cost.** Payroll costs and other compensation of Contractor's officers, executives, principals, general managers, engineers, architects, estimators, attorneys, auditors, accountants, purchasing and contracting agents, timekeepers, clerks, and other personnel employed by Contractor whether at the Site or in Contractor's principal office or any branch office, material yard, or shop for general administration of the Work;
  - (ii) **Office Expenses.** Expenses of Contractor's principal and branch offices;
  - (iii) **Capital Expenses.** Any part of Contractor's capital expenses, including interest on Contractor's capital employed for the Additional Work and charges against Contractor for delinquent payments;
  - (iv) **Negligence.** Costs due to the negligence of Contractor or any Subcontractor or Supplier, or anyone directly or indirectly employed by any of them or for whose acts any of them may be liable, including without limitation the correction of Defective Work, disposal of materials or equipment wrongly supplied, and making good any damage to property;
  - (v) **Small Tools.** Cost of small tools valued at less than \$1,000 and that remain the property of Contractor;
  - (vi) **Administrative Costs.** Costs associated with the preparation of Change Orders (whether or not ultimately authorized), cost estimates, or the preparation or filing of Claims;
  - (vii) **Anticipated Lost Profits.** Expenses of Contractor associated with anticipated lost profits or lost revenues, lost income or earnings, lost interest on earnings, or unpaid retention;
  - (viii) **Home Office Overhead.** Costs derived from the computation of a "home office overhead" rate by application of the *Eichleay*, *Allegheny*, burden fluctuation, or other similar methods;

- (ix) Special Consultants and Attorneys. Costs of special consultants or attorneys, whether or not in the direct employ of Contractor, employed for services specifically related to the resolution of a Claim, dispute, or other matter arising out of or relating to the performance of the Additional Work.
- (x) Other. Other overhead or general expense costs of any kind and the cost of any item not specifically and expressly included in the Contract Documents; including but not limited to: submittals, drawings, field drawings, shop drawings, including submissions of drawings; field inspection; general superintendence; computer services; reproduction services; salaries of project engineer, superintendent, timekeeper, storekeeper, and secretaries; janitorial services; small tools, incidentals and consumables; temporary on-site facilities (offices, telephones, high speed internet access, plumbing, electrical power, lighting; platforms, fencing, water); surveying; estimating; protection of work; handling and disposal fees; final cleanup; other incidental work; related warranties; insurance and bond premiums.
- (xi) Compliance with Federal Cost Principles. If the Project is federally funded, any costs that are not allowable, reasonable, and allocable to the Project, under generally accepted accounting principles and the applicable federal requirements.

A new **Section 6-14** is **added** to the Greenbook, as follows,

**6-14 Resolving Claims.** Contractor shall timely comply with any and all requirement of the Contract Documents pertaining to notices and requests for changes to the Contract Time or Contract Price, including but not limited to all requirements of 6-13, as a prerequisite to filing any claim governed by this Section. The failure to timely submit a notice of delay or notice of change, or to timely request a change to the time for completion or Contractor's compensation, or to timely provide any other notice or request required herein shall constitute a waiver of the right to further pursue the claim under the Contract or at law.

A. **Intent.** Effective January 1, 1991, Section 20104 et seq., of the California Public Contract Code prescribes a process utilizing informal conferences, non-binding judicial supervised mediation, and judicial arbitration to resolve disputes on construction claims of \$375,000 or less. Effective January 1, 2017, Section 9204 of the Public Contract Code prescribes a process for negotiation and mediation to resolve disputes on construction claims. The intent of this Section is to implement Sections 20104 et seq. and Section 9204 of the California Public Contract Code. This Section shall be construed to be consistent with all applicable law, including but not limited to these statutes.

B. **Claims.** For purposes of this Section, "Claim" means a separate demand by the Contractor for:

1. An adjustment to the time for completion including, without limitation, for relief from damages or penalties for delay assessed by the City;
2. Payment by the City of money or damages arising from Work done by or on behalf of the Contractor pursuant to the Contract, payment for which is not otherwise expressly provided or to which the Contractor is not otherwise entitled; or
3. An amount the payment of which is disputed by the City.

A "Claim" does not include any demand for payment for which the Contractor has failed to provide notice, request a Change Order, or otherwise failed to follow any procedures contained in the Contract Documents.

C. **Filing Claims.** Claims governed by this Section may not be filed unless and until the Contractor completes any and all requirements of the Contract Documents pertaining to notices and requests for changes to the Contract Time or Contract Price, and Contractor's request for a change has been denied in whole or in part. Claims governed by this Section must be filed no later than thirty (30) Days after a request for change has been denied in whole or in part or after any other event giving rise to the Claim. The Claim shall be submitted in writing to the City and shall include on its first page the following words in 16 point capital font: "THIS IS A CLAIM." The Claim shall include all information and documents necessary to substantiate the Claim, including but not limited to those identified below. Nothing in this Section is intended to extend the time limit or supersede notice requirements otherwise provided by Contract Documents. Failure to follow such contractual requirements shall bar any Claims or subsequent proceedings for compensation or payment thereon.

D. **Documentation.** The Contractor shall submit all Claims in the following format:

1. Summary description of Claim including basis of entitlement, merit and amount of time or money requested, with specific reference to the Contract Document provisions pursuant to which the Claim is made
  2. List of documents relating to Claim:
    - a. Specifications
    - b. Drawings
    - c. Clarifications (Requests for Information)
    - d. Schedules
    - e. Other
  3. Chronology of events and correspondence
  4. Narrative analysis of Claim merit
  5. Analysis of Claim cost, including calculations and supporting documents
  6. Time impact analysis in the form required by the Contract Documents or, if the Contract Documents do not require a particular format, CPM format, if an adjustment of the Contract Time is requested
- E. **City's Response.** Upon receipt of a Claim pursuant to this Section, the City shall conduct a reasonable review of the Claim and, within a period not to exceed 45 Days, shall provide the Contractor a written statement identifying what portion of the Claim is disputed and what portion is undisputed. Any payment due on an undisputed portion of the Claim will be processed and made within 60 Days after the City issues its written statement.
1. If the City needs approval from its governing body to provide the Contractor a written statement identifying the disputed portion and the undisputed portion of the Claim, and the City's governing body does not meet within the 45 Days or within the mutually agreed to extension of time following receipt of a Claim sent by registered mail or certified mail, return receipt requested, the City shall have up to three (3) Days following the next duly publicly noticed meeting of the City's governing body after the 45-Day period, or extension, expires to provide the Contractor a written statement identifying the disputed portion and the undisputed portion.
  2. Within 30 Days of receipt of a Claim, the City may request in writing additional documentation supporting the Claim or relating to defenses or Claims the City may have against the Contractor. If additional information is thereafter required, it shall be requested and provided pursuant to this subdivision, upon mutual agreement of the City and the Contractor. The City's written response to the Claim, as further documented, shall be submitted to the Contractor within 30 Days (if the Claim is less than \$50,000, within 15 Days) after receipt of the further documentation, or

within a period of time no greater than that taken by the Contractor in producing the additional information or requested documentation, whichever is greater.

- F. **Meet and Confer.** If the Contractor disputes the City's written response, or the City fails to respond within the time prescribed, the Contractor may so notify the City, in writing, either within 15 Days of receipt of the City's response or within 15 Days of the City's failure to respond within the time prescribed, respectively, and demand in writing an informal conference to meet and confer for settlement of the issues in dispute. Upon receipt of a demand, the City shall schedule a meet and confer conference within 30 Days for settlement of the dispute.
- G. **Mediation.** Within 10 business days following the conclusion of the meet and confer conference, if the Claim or any portion of the Claim remains in dispute, the City shall provide the Contractor a written statement identifying the portion of the Claim that remains in dispute and the portion that is undisputed. Any payment due on an undisputed portion of the Claim shall be processed and made within 60 Days after the City issues its written statement. Any disputed portion of the Claim, as identified by the Contractor in writing, shall be submitted to nonbinding mediation, with the City and the Contractor sharing the associated costs equally. The public entity and Contractor shall mutually agree to a mediator within 10 business days after the disputed portion of the Claim has been identified in writing, unless the parties agree to select a mediator at a later time.
1. If the parties cannot agree upon a mediator, each party shall select a mediator and those mediators shall select a qualified neutral third party to mediate with regard to the disputed portion of the Claim. Each party shall bear the fees and costs charged by its respective mediator in connection with the selection of the neutral mediator.
  2. For purposes of this Section, mediation includes any nonbinding process, including, but not limited to, neutral evaluation or a dispute review board, in which an independent third party or board assists the parties in dispute resolution through negotiation or by issuance of an evaluation. Any mediation utilized shall conform to the timeframes in this Section.
  3. Unless otherwise agreed to by the City and the Contractor in writing, the mediation conducted pursuant to this section shall excuse any further obligation under Section 20104.4 of the California Public Contract Code to mediate after litigation has been commenced.
  4. The mediation shall be held no earlier than the date the Contractor completes the Work or the date that the Contractor last performs Work, whichever is earlier. All unresolved Claims shall be considered jointly in a single mediation, unless a new unrelated Claim arises after mediation is completed.
- H. **Procedures After Mediation.** If following the mediation, the Claim or any portion remains in dispute, the Contractor must file a Claim pursuant to Chapter 1 (commencing with Section 900) and Chapter 2 (commencing with Section 910) of Part

3 of Division 3.6 of Title 1 of the Government Code prior to initiating litigation. For purposes of those provisions, the running of the period of time within which a Claim must be filed shall be tolled from the time the Contractor submits his or her written Claim pursuant to subdivision (a) until the time the Claim is denied, including any period of time utilized by the meet and confer conference.

I. **Civil Actions.** The following procedures are established for all civil actions filed to resolve Claims of \$375,000 or less:

1. Within 60 Days, but no earlier than 30 Days, following the filing or responsive pleadings, the court shall submit the matter to non-binding mediation unless waived by mutual stipulation of both parties or unless mediation was held prior to commencement of the action in accordance with Public Contract Code section 9204 and the terms of this Contract. The mediation process shall provide for the selection within 15 Days by both parties of a disinterested third person as mediator, shall be commenced within 30 Days of the submittal, and shall be concluded within 15 Days from the commencement of the mediation unless a time requirement is extended upon a good cause showing to the court.
2. If the matter remains in dispute, the case shall be submitted to judicial arbitration pursuant to Chapter 2.5 (commencing with Section 1141.10) of Title 3 of Part 3 of the Code of Civil Procedure, notwithstanding Section 1114.11 of that code. The Civil Discovery Act of 1986 (Article 3 (commencing with Section 2016) of Chapter 3 of Title 3 of Part 4 of the Code of Civil Procedure) shall apply to any proceeding brought under this subdivision consistent with the rules pertaining to judicial arbitration. In addition to Chapter 2.5 (commencing with Section 1141.10) of Title 3 of Part 3 of the Code of Civil Procedure, (A) arbitrators shall, when possible, be experienced in construction law, and (B) any party appealing an arbitration award who does not obtain a more favorable judgment shall, in addition to payment of costs and fees under that chapter, also pay the attorney's fees on appeal of the other party.

J. **Government Code Claim Procedures.**

1. This Section does not apply to tort claims and nothing in this Section is intended nor shall be construed to change the time periods for filing tort claims or actions specified by Chapter 1 (commencing with Section 900) and Chapter 2 (commencing with Section 910) of Part 3 of Division 3.5 of Title 1 of the Government Code.
2. In addition to any and all requirements of the Contract Documents pertaining to notices of and requests for adjustment to the Contract Time, Contract Price, or compensation or payment for Additional Work, disputed Work, construction claims and/or changed conditions, the Contractor must comply with the claim procedures set forth in Government Code Section 900, et seq. prior to filing any lawsuit against the City.
3. Such Government Code claims and any subsequent lawsuit based upon the Government Code claims shall be limited to those matters that remain unresolved after all procedures pertaining to adjustment of the Contract Time or Contract Price

for Additional Work, disputed Work, construction claims, and/or changed conditions have been followed by Contractor. If Contractor does not comply with the Government Code claim procedure or the prerequisite contractual requirements, Contractor may not file any action against the City.

4. **A Government Code claim must be filed no earlier than the date the Work is completed or the date the Contractor last performs Work on the Project, whichever occurs first. A Government Code claim shall be inclusive of all unresolved Claims known to Contractor or that should reasonably be known to Contractor excepting only new unrelated Claims that arise after the Government Code claim is submitted.**
  
- K. **Non-Waiver.** The City's failure to respond to a Claim from the Contractor within the time periods described in this Section or to otherwise meet the time requirements of this Section shall result in the Claim being deemed rejected in its entirety, and shall not constitute a waiver of any rights under this Section.

## **SECTION 7 MEASUREMENT AND PAYMENT**

### **7-2 Lump Sum Work.**

**Section 7-2** shall be **amended** to read as follows,

Items for which quantities are indicated "Lump Sum", "LS", or "Job", shall be paid for at the price indicated in the Bid. Such payment shall be full compensation for the items of work and all work appurtenant thereto.

Contractor shall furnish on forms approved by the City within ten (10) Days of the Notice to Proceed, a schedule of values allocating the entire Contract Price to the various portions of the Work and prepared in such a form and supported by such data to substantiate its accuracy as the Engineer may require. This schedule of values, unless objected to by the Engineer, shall be used as a basis for reviewing the Contractor's applications for payment. Contractor shall submit the schedule of values prior to submitting its first application for payment, and the City will not issue any payment until it receives and approves the schedule of values.

### **7-3 Payment.**

#### **7-3.1 General.**

**Section 7-3.1** of the Greenbook shall be **amended** to include the following:

Pursuant to section 22300 of the Public Contract Code of the State of California, Contractor may request the City to make retention payments directly to an escrow agent or may substitute securities for any money withheld by the City to ensure performance under the contract. At the request and expense of Contractor, securities equivalent to the amount withheld shall be deposited with the City or with a state or federally chartered bank as the escrow agent who shall return such securities to Contractor upon satisfactory completion of the contract. Deposit of securities with an escrow agent shall be subject to a written agreement substantially in the form provided in section 22300 of the Public Contract Code.

A new **Section 7-3.1.1** is **added** to the Greenbook, as follows,

**7-3.1.1 Progress Estimates and Payment.**

- A. By the tenth (10th) Day of the following calendar month, Contractor shall submit to Engineer a payment request which shall set forth in detail the value of the Work done for the period beginning with the date Work was first commenced and ending on the end of the calendar month for which the payment request is prepared. Contractor shall include an adjusted list of actual quantities, verified by the Engineer, for unit price items listed, if any, in the Bid. Contractor shall include any amount earned for authorized Additional Work. Contractor shall certify under penalty of perjury, that all cost breakdowns and periodic estimates accurately reflect the Work on the Project.
- B. From the total thus computed, a deduction shall be made in the amount of five percent (5%) for retention, except where the City has adopted a finding that the Work done under the Contract is substantially complex, and then the amount withheld as retention shall be the percentage specified in the Notice Inviting Bids. From the remainder a further deduction may be made in accordance with Section C below. The amount computed, less the amount withheld for retention and any amounts withheld as set forth below, shall be the amount of the Contractor's payment request.
- C. The City may withhold a sufficient amount or amounts of any payment or payments otherwise due to Contractor, as in its judgment may be necessary to cover:
  - 1. Payments which may be past due and payable for just claims against Contractor or any Subcontractors for labor or materials furnished in and about the performance of work on the Project under this Contract.
  - 2. Defective work not remedied.
  - 3. Failure of Contractor to make proper payments to his Subcontractor or for material or labor.
  - 4. Completion of the Contract if there is a reasonable doubt that the Work can be completed for balance then unpaid.
  - 5. Damage to another contractor or a third party.
  - 6. Amounts which may be due the Count for claims against Contractor.
  - 7. Failure of Contractor to keep the Record Drawings up to date.

8. Failure to provide update on construction schedule as required herein.
  9. Site cleanup.
  10. Failure to comply with Contract Documents.
  11. Liquidated damages.
  12. Legally permitted penalties.
- D. The City may apply such withheld amount or amounts to payment of such claims or obligations at its discretion with the exception of subsections (C)(1), (3), and (5) of this Section, which must be retained or applied in accordance with applicable law. In so doing, the City shall be deemed the agent of Contractor and any payment so made by the City shall be considered as a payment made under contract by the City to Contractor and the City shall not be liable to Contractor for such payments made in good faith. Such payments may be made without prior judicial determination of claim or obligations. The City will render Contractor a proper accounting of such funds disbursed on behalf of Contractor.
- E. Upon receipt, the Engineer shall review the payment request to determine whether it is undisputed and suitable for payment. If the payment request is determined to be unsuitable for payment, it shall be returned to Contractor as soon as practicable but not later than seven (7) Days after receipt, accompanied by a document setting forth in writing the reasons why the payment request is not proper. The City shall make the progress payment within 30 Days after the receipt of an undisputed and properly submitted payment request from Contractor, provided that a release of liens and claims has been received from the Contractor pursuant to Civil Code section 8132. The number of days available to the City to make a payment without incurring interest pursuant to this paragraph shall be reduced by the number of Days by which the Engineer exceeds the seven (7) Day requirement.
- F. A payment request shall be considered properly executed if funds are available for payment of the payment request and payment is not delayed due to an audit inquiry by the financial officer of the City.
- G. The City shall have the right to adjust any estimate of quantity and to subsequently correct any error made in any estimate for payment.

### **7-3.2 Partial and Final Payment.**

A new **Section 7-3.2.1** is **added** to the Greenbook, as follows,

#### **7-3.2.1 Final Acceptance and Payment.**

- A. Following the City's acceptance of the Work, the Contractor shall submit to the City a written statement of the final quantities of unit price items for inclusion in the final payment request. The City shall have the right to adjust any estimate of quantity and to correct any error made in any estimate for payment.
- B. When the Work has been accepted there shall be paid to Contractor a sum equal to the Contract Price less any amounts previously paid Contractor and less any amounts withheld by the City from Contractor under the terms of the Contract. The final five percent (5%), or the percentage specified in the Notice Inviting Bids where the City has adopted a finding of substantially complete, shall not become due and payable until as required by Public Contract Code section 7107. If the Contractor has placed securities with the City as described herein, the Contractor shall be paid a sum equal to one hundred percent (100%) of the Contract Price less any amounts due the City under the terms of the Contract.
- C. Unless Contractor advises the City in writing prior to acceptance of the final five percent (5%) or the percentage specified in the Notice Inviting Bids where the City has adopted a finding of completion, or the return of securities held as described herein, said acceptance shall operate as a release to the City of all claims and all liability to Contractor for all things done or furnished in connection with this Work and for every act of negligence of the City and for all other claims relating to or arising out of this Work. If Contractor advises the City in writing prior to acceptance of final payment or return of the securities that there is a dispute regarding the amount due the Contractor, the City may pay the undisputed amount contingent upon the Contractor furnishing a release of all undisputed claims against the City with the disputed claims in stated amounts being specifically excluded by Contractor from the operation of the release. No payments, however, final or otherwise, shall operate to release Contractor or its sureties from the Faithful Performance Bond, Labor and Material Payment Bond, or from any other obligation under this Contract.
- D. In case of suspension of the Contract any unpaid balance shall be and become the sole and absolute property of the City to the extent necessary to repay the City any excess in the cost of the Work above the Contract Price.
- E. Final payment shall be made no later than 60 Days after the date of acceptance of the Work by the City or the date of occupation, beneficial use and enjoyment of the Work by the City including any operation only for testing, start-up or commissioning accompanied by cessation of labor on the Work, provided that a release of liens and claims has been received from the Contractor pursuant to Civil Code

section 8136. In the event of a dispute between the City and the Contractor, the City may withhold from the final payment an amount not to exceed 150% of the disputed amount.

- F. Within ten (10) Days from the time that all or any portion of the retention proceeds are received by Contractor, Contractor shall pay each of its Subcontractors from whom retention has been withheld each Subcontractor's share of the retention received. However, if a retention payment received by Contractor is specifically designated for a particular Subcontractor, payment of the retention shall be made to the designated Subcontractor if the payment is consistent with the terms of the subcontract.

#### **7-3.4 Mobilization.**

**Section 7-3.4** of the Greenbook shall be **amended** to include the following:

Payment for mobilization shall be included in the contract unit prices bid for the various items of work involved, and no additional compensation will be allowed therefore. The scope of the Work included under mobilization shall include, but shall not be limited to, the following principal items:

1. Obtaining and paying for all bonds, insurance, and permits.
2. Moving on to the Project Site of all Contractor's plant and equipment required for the first month's operations.
3. Installing temporary construction power, wiring, and lighting facilities, as applicable.
4. Establishing fire protection system, as applicable.
5. Developing and installing a construction water supply, as applicable.
6. Providing and maintaining the field office trailers for the Contractor, if necessary, and the Engineer (if specified), complete, with all specified furnishings and utility services.
7. Providing on-site sanitary facilities and potable water facilities as specified per Cal-OSHA and these Contract Documents.
8. Furnishing, installing, and maintaining all storage buildings or sheds required for temporary storage of products, equipment, or materials that have not yet been installed in the Work. All such storage shall meet manufacturer's specified storage requirements, and the specific provisions of the specifications, including temperature and humidity control, if recommended by the manufacturer, and for all security.
9. Arranging for and erection of Contractor's work and storage yard.

10. Posting all OSHA required notices and establishment of safety programs per Cal-OSHA.
11. Full-time presence of Contractor's superintendent at the job Site as required herein.
12. Submittal of construction schedule as required by the Contract Documents.
13. Demobilization from construction site upon completion of Improvements Project.

### **7-3.5 Contract Unit Prices.**

**Section 7-3.5** shall be **amended** to read as follows,

1. Where the Contract Documents provide that all or part of the Work is to be Unit Price Work, initially the Contract Price will be deemed to include for all Unit Price Work an amount equal to the sum of the unit price for each separately identified item of Unit Price Work multiplied by the estimated quantity of each item as indicated in the Contract. The estimated quantities of items of Unit Price Work are not guaranteed and are solely for the purpose of comparison of Bids and determining an initial Contract Price. Each unit price will be deemed to include an amount considered by Contractor to be adequate to cover Contractor's overhead and or profit for each separately identified item.
2. Unless otherwise specified, payment will be based on the actual quantities of Work as verified and approved by the Engineer, based on the price per unit as set forth in the Bid.
3. The City or Contractor may initiate a Change Order or Change Order Request to adjust the Contract Price in accordance with Contractor Documents based on actual quantities of Unit Price Work. The City or Contractor may make a claim for an adjustment in the Unit Price in accordance with the Contract Documents if:
  - a. the quantity of any item of Unit Price Work performed by Contractor differs by twenty-five percent (25%) or more from the estimated quantity of such item indicated in the Contract; and
  - b. there is no corresponding adjustment with respect to any other item of Work; and
  - c. Contractor believes that Contractor is entitled to an increase in unit price as a result of having incurred additional expense or the City believes that the City is entitled to a decrease in unit price and the parties are unable to agree as to the amount of any such increase or decrease.

If the actual quantity of an item or work covered by a Contract Unit Price and constructed in conformance with the Plans and Specifications varies from the Bid quantity by 25 percent or less, payment will be made at the Contract Unit Price. If

the actual quantity of said item of work varies from the bid quantity by more than 25 percent, payment will be made per 7-3.5.2 or 7-3.5.3 as appropriate.

If a change is ordered in an item of work covered by a Contract Unit Price, and such change does involve a substantial change in the character of the work from that shown on the Plans or specified in the Specifications, an adjustment in payment will be made per 7-3.7.

A new **Section 7-3.9** hereby is **added** to the *Greenbook* as follows:

**7-3.9 Resolution of Construction Claims.** Pursuant to the requirements of California Public Contract Code § 20104(c), set forth below is the procedure for resolution of construction claims by the contractor. This provision shall only apply to those claims specified in § 20104 of the California Public Contract Code:

**§ 20104. Application of article; inclusion of article in plans and specifications**

(a)(1) This article applies to all public works claims of three hundred seventy-five thousand dollars (\$375,000.00) or less which arise between a contractor and a local agency.

(2) This article shall not apply to any claims resulting from a contract between a contractor and a public agency when the public agency has elected to resolve any disputes pursuant to Article 7.1 (commencing with § 10240) of Chapter 1 or Part 2.

(b)(1) "Public work" means a public work contract as defined in §§ 1101, 3100 and 3106 of the Public Contract Code, but does not include any work or improvement contracted for by the state or the Regents of the University of California.

(2) "Claim" means a separate demand by the Contractor for (A) a time extension, (B) payment of money of damages arising from work done by or on behalf of the contractor pursuant to the contract for a public work and payment of which is not otherwise expressly provided for or the claimant is not otherwise entitled to, or (c) an amount the payment of which is disputed by the local agency.

(c) The provisions of this article or a summary thereof shall be set forth in the plans or specifications for any work which may give rise to a claim under this article.

(d) This article applies only to contracts entered into on or after January 1, 1991.

**§ 20104.2 Claims; Requirements; Tort Claims Excluded**

For any claim subject to this article, the following requirements apply:

(a) The claim shall be in writing and include the documents necessary to substantiate the claim. Claims must be filed on or before the date of final payment. Nothing in this subdivision is intended to extend the time limit or supersede notice requirements otherwise provided by contract for the filing of claims.

(b)(1) For claims of less than fifty thousand dollars (\$50,000.00), the local agency shall respond in writing to any written claim within 45 days of receipt of the claim, or may request, in writing, within 30 days of receipt of the claim, any additional documentation supporting the claim or relating to defenses or claims the local agency may have against the claimant.

(2) If additional information is thereafter required, it shall be requested and provided pursuant to this subdivision, upon mutual agreement of the local agency and the claimant.

(3) The local agency's written response to the claim, as further documented, shall be submitted to the claimant within 15 days after receipt of the further documentation or within a period of time no greater than that taken by the claimant in producing the additional information, whichever is greater.

(c)(1) For claims of over fifty thousand dollars (\$50,000.00) and less than or equal to three hundred seventy-five thousand dollars (\$375,000.00), the local agency shall respond in writing to all written claims within 60 days of receipt of the claim, or may request, in writing, within 30 days of receipt of the claim, any additional documentation supporting the claim or relating to defenses or claims the local agency may have against the claimant.

(2) If additional information is thereafter required, it shall be requested and provided pursuant to this subdivision, upon mutual agreement of the local agency and the claimant.

(3) The local agency's written response to the claim, as further documented, shall be submitted to the claimant within 30 days after receipt of the further documentation or within a period of time no greater than that taken by the claimant in producing the additional information or requested documents, whichever is greater.

(d) If the claimant disputes the local agency's written response, or the local agency fails to respond within the time prescribed, the claimant may so notify the local agency, in writing, either within 15 days of receipt of the local agency's response or within 15 days of the local agency's failure to respond within the time prescribed, respectively, and demand an informal conference to meet and confer for settlement of the issues in dispute. Upon a demand, the local agency shall schedule a meet and confer conference within 30 days for settlement of the dispute.

(e) Following the meet and confer conference, if the claim or any portion remains in dispute, the claimant may file a claim pursuant to

Chapter 1 (commencing with § 900) and Chapter 2 (commencing with § 910) of Part 3 of Division 3.6 of Title 1 of the Government Code. For purposes of those provisions, the running of the period of time within which a claim must be filed shall be tolled from the time the claimant submits his or her written claim pursuant to subdivision (a) until the time the claim is denied, including any period of time utilized by the meet and confer conference.

(f) This article does not apply to tort claims and nothing in this article is intended nor shall be construed to change the time periods for filing tort claims or actions specified by Chapter 1 (commencing with § 900) and Chapter 2 (commencing with § 910) of Part 3 of Division 3.6 of Title 1 of the Government Code.

#### **§ 20104.4 Civil action procedures; mediation and arbitration; trial de novo; witnesses**

The following procedures are established for all civil actions filed to resolve claims subject to this article:

(a) Within sixty (60) days, but no earlier than thirty (30) days, following the filing of responsive pleadings, the court shall submit the matter to nonbinding mediation unless waived by mutual stipulation of both parties. The mediation process shall provide for the selection within fifteen (15) days by both parties of a disinterested third person as mediator, shall be commenced within thirty (30) days of the submittal, and shall be concluded within fifteen (15) days from the commencement of the mediation unless a time requirement is extended upon good cause showing to the court or by stipulation of both parties. If the parties fail to select a mediator within the fifteen (15) day period, any party may petition the court to appoint the mediator.

(b)(1) If the matter remains in dispute, the case shall be submitted to judicial arbitration pursuant to Chapter 2.5 (commencing with § 1141.10) of Title 3 of Part 3 of the Code of Civil Procedure, notwithstanding § 11411.11 of that code. The Civil Discovery Act of 1986 (Article 3 (commencing with § 2016) of Chapter 3 of Title 3 of Part 4 of the code of Civil Procedure) shall apply to any proceeding brought under this subdivision consistent with the rules pertaining to judicial arbitration.

(2) Notwithstanding any other provision of law, upon stipulation of the parties, arbitrators appointed for purposes of this article shall be experienced in construction law, and, upon stipulation of the parties, mediators and arbitrators shall be paid necessary and reasonable hourly rates of pay not to exceed their customary rate, and such fees and expense shall be paid equally by the parties, except in the case of arbitration where the arbitrator, for good cause, determines a different division. In no event shall these fees or expenses be paid by state or county funds.

(3) In addition to Chapter 2.5 (commencing with § 1411.10) of Title 3 of Part 3 of the Code of Civil Procedure, any party who after receiving an arbitration award requests a trial de novo but does not obtain a more favorable judgment shall, in addition to payment of costs and fees under that chapter, also pay the attorney's fees on appeal of the other party arising out of the trial de novo.

(c) The court may, upon request by any party, order any witness to participate in the mediation or arbitration process.

**§ 20104.6 Payment on undisputed portion of claim; interest on arbitration awards or judgments**

(a) No local agency shall fail to pay money as to any portion of a claim which is undisputed except as otherwise provided in the contract.

(b) In any suit filed under § 20104.4, the local agency shall pay interest at the legal rate on any arbitration award or judgment. The interest shall begin to accrue on the date the suit is filed in a court of law.

**7-4.3 Markup**

**Section 7-4.3.1 and 7-4.3.2** of the Greenbook shall be **replaced** in its entirety with the following:

**7-4.3.1 Work by Contractor.** The following percentages shall be added to the Contractor's costs and shall constitute the entire markup for all overhead and profits:

- 1. Labor .....15%
- 2. Materials .....10%
- 3. Equipment Rental ..... 8%
- 4. Other Items and Expenditures..... 5%

To the sum of the costs and markups provided for in this subsection, 1% shall be added as compensation for bonding.

**7-4.3.2 Work by Subcontractor.** When all or part of the extra work is performed by a Subcontractor, the markup established in 3-3.2.3(a) shall be applied to the Subcontractor's actual cost of such work. A markup of 10 percent on the first \$5,000 of the subcontracted portion of the extra work and a markup of 5 percent on the work added in excess of \$5,000 of the subcontracted portion of the extra work may be added by the Contractor.

**SECTION 8 FACILITIES FOR AGENCY PERSONNEL**

**8-1 General.**

**Section 8-1** of the Greenbook shall be **amended** to include the following:

The City, Engineer, their consultants and other representatives and personnel, independent testing laboratories, and governmental agencies with jurisdictional interests will have access to the Site and the Work at reasonable times for their observation, inspection, and testing. Contractor shall provide them proper and safe conditions for such access and advise them of Contractor's safety procedures and programs.

**9-1 Fleet Compliance.**

- 1.2 To the extent applicable, Contractor, shall comply, and shall ensure all subcontractors comply, with all requirements of the most current version of the California Air Resources Board ("CARB") including, without limitation, all applicable terms of Title 13, California Code of Regulations Division 3, Chapter 9 and all pending amendments ("Regulation").
- 1.3 Throughout Project, and for three (3) years thereafter, Contractor shall make available for inspection and copying any and all documents or information associated with Contractor's and subcontractors' fleet including, without limitation, the CRCs, fuel/refueling records, maintenance records, emissions records, and any other information the Contractor is required to produce, keep or maintain pursuant to the Regulation upon two (2) calendar days' notice from the City.
- 1.4 Contractor shall be solely liable for any and all costs associated with complying with the Regulation as well as for any and all penalties, fines, damages, or costs associated with any and all violations, or failures to comply with the Regulation. Contractor shall defend, indemnify and hold harmless the City, its officials, officers, employees and authorized volunteers free and harmless from any claims, liabilities, costs, penalties or interest arising out of any failure or alleged failure to comply with the Regulation.

**END OF GENERAL PROVISIONS**

## SPECIAL PROVISIONS

### **SECTION 1 GENERAL REQUIREMENTS**

#### **1.1 General**

The Contractor shall furnish in accordance with the plans and specifications, all labor, equipment, time, and materials required for the construction of all work as outlined herein. All work shall comply with the **2018 edition** of the Standard Specifications for Public Works Construction (SSPWC), commonly known as the "Green Book", the Standard Plans for Public Works Construction (SPPWC), and the latest edition of Caltrans Standard Specifications, and Caltrans Standard Plan.

The Contractor shall furnish in accordance with the plans and specifications, all labor, materials, tools, equipment, time, and incidentals required for the construction of all work as outlined herein.

***Unless specifically covered under a separate bid item on Section 2, "Definition of Bid Items," or noted below, full compensation for complying with all the requirements of this Section 1, "General Requirements," shall be considered as included in the various bid items of work, and no additional compensation will be allowed or paid for.***

#### **1.2 Description of Work**

The work to be performed under this Contract generally consists of mobilization; traffic control; SWPPP plan and implementation; surveying; potholing; work site safety and shoring; clearing and grubbing; removal and disposal of asphalt concrete pavement, and PCC improvements; construction of asphalt pavement; construction of PCC driveways, sidewalk, curb and gutter, and all appurtenant work necessary for the proper construction of the contemplated improvements in accordance with the Plans and Specifications entitled Project No. 7031, 85003 & 86004 11th Street Flashing Signal Beacon & Alley Improvements. The Contractor will furnish all transportation, materials, tools, time, equipment, labor, and supplies to complete the improvements, together with the appurtenant work necessary or incidental to complete, in a workmanlike manner, the improvements as contemplated and as intended by the Plans and Specifications.

#### **1.3 Utilities**

Existing utilities shown on the plans are based on available records and surface features; however, neither the City nor the Engineer assumes any responsibility for having completely and precisely shown all such existing utilities. The Contractor shall notify all utility companies and agencies serving the project area before beginning any excavations, and shall coordinate all work with them.

The Contractor shall notify Underground Service Alert (USA) by calling 1-800-227-2600, at least two (2) working days prior to beginning any excavations. Following such notice, the Contractor shall submit to the Engineer the date of notice and corresponding assigned ticket number.

The California Department of Transportation is not required by Section 4216 of the California Government Code to become a member of the regional notification center. The Contractor shall contact Caltrans for location of their subsurface installations.

Full compensation for satisfying the requirements of this section and all subsections shall be considered as included in the contract prices bid for the various items of work involved and no additional compensation will be allowed therefor.

### 1.3.1 Utility Contacts

The following is a list of individuals or entities, which may have facilities that may be affected by the proposed improvements. This list is merely for the Contractor's information and may or may not be complete or inclusive. It is the Contractor's responsibility to coordinate his work with affected utility companies or agencies.

Company / Entity	Contact	Phone Number
City of Upland (Engineering Division)	Bob Critchfield	(909) 291-2946
City of Upland (Water Division)	Mark Warner	(909) 912-4416
City of Upland (Sewer & Storm Drain)	Nicole deMoet	(909) 291-2970
AT&T	Floyd Dizon	(714) 618-9126
Frontier Communications	Recinto Bonifacio	(909) 488-8875
Metropolitan Water District (MWD)	John Osornia Mike Rubio	(909) 392-5095 (951) 776-2675
San Antonio Water Company	Brian Lee	(909) 982-4107
Southern California Edison Company	Timothy Johnson	(661) 388-3076
Sprint	Lynn Durrett	(909) 873-8022
So Cal Gas Company	David Castellanos	(909) 335-7508
Spectrum Communications	Customer Service	(888) 892-2253
Underground Service Alert		(800) 227-2600
Verizon (General Telephone)	Amin Abouelhouda	(909) 469-6369
Frontier Communications (General Telephone)		(909) 469-6369
Water Facilities Authority	Terry Katlin	(909) 981-9454

It is the Contractor's responsibility to contact all utility agencies affected by the work to be completed, verify all utility information, and coordinate all work with respect to the utilities' possible obstructions and/or interference.

The Contractor shall contact the City of Upland, Engineering Office, at least two working days prior to pavement saw cutting or grinding near inductive loop detectors, in order to allow sufficient time for disconnection of vehicle detection and reprogramming traffic signal timing.

Prior to the paving operation, the Contractor shall notify all utility companies who have facilities, (vaults, valves, etc.), on the street to be resurfaced in order that they

may schedule their work accordingly in adjusting their vaults or valves to the new grade. The Contractor may be required to assist them during their adjusting operation.

### **1.3.2 Location and Protection**

The provisions of Section 5 “Utilities” of the SSPWC shall apply, except as modified and supplemented below:

The Contractor shall verify the existence and location of any underground utility pipes or structures that may be affected during the course of work. The Contractor will take due precautionary measures to protect the utilities shown, and other utilities or structures not shown on the plans that might be discovered during the process of the job.

Where underground main distribution conduits such as water, gas, sewer, electric power, telephone, cable television or traffic signal are shown on the Plans, the Contractor, for the purpose of preparing a Bid, shall assume that every property parcel will be served by a service connection for each type of utility.

The City of Upland Water Operations Division has water services and mains in the vicinity of where construction operations will be conducted by the Contractor. Care shall be taken by the Contractor not to disturb the water mains, services, meters, valves, etc. during construction operations. In the event that a water facility is damaged, the Contractor shall notify the Water Division and the Engineering Division immediately. The Contractor shall also arrange for the immediate repair of the water facility by a properly California licensed contractor, at no cost to the City. The Contractor will not be compensated for any damages or delays as a result of water facility repairs.

Payment for location and protection of utilities shall be considered to be included in the prices paid for the various contract items of work, and no additional compensation will be allowed or paid for, and shall include repair of damaged utilities caused by the Contractor’s operations.

### **1.3.3 Removal**

The provisions of Section 401 “Removal” of the SSPWC shall apply, except as modified and supplemented below:

Unless otherwise specified, the Contractor shall remove or abandon all interfering portions of utilities shown on the Plans, or indicated in the Bid documents as “abandoned” or “to be abandoned in place”. Before starting removal operations, the Contractor shall ascertain from the Agency that the abandonment is complete. The costs involved in the removal and disposal, or abandonment shall be included in the various bid items or work, and no additional compensation will be allowed or paid for.

### **1.3.4 Compensation for Damage or Relocation**

In accordance with Section 4215 of the California Government Code, the Contractor shall be compensated for the cost of locating and repairing damage to main or trunk line utility facilities located on the job site, not due to the failure of the Contractor to exercise reasonable care; for costs of removing or relocating such utility facilities not indicated in the Contract Documents with reasonable accuracy; and for the operating costs for equipment on the project necessarily idled during such work.

If the Contractor wishes to have any utility located, he should contact the owner at least 48 hours prior to construction in the immediate vicinity of the utility. Potholing to locate existing underground utilities shall be the responsibility of the utility owner or the contractor, and no further compensation shall be allowed therefor.

## **1.4 COORDINATION WITH CITY OF UPLAND, OTHER AGENCIES, AND UTILITIES**

### **1.4.1 City of Upland**

The Contractor shall contact the Engineering Manager, Bob Critchfield at (909) 291-2946, at least two working days prior to pavement sawcutting or grinding near inductive loop detectors, in order to allow sufficient time for disconnection of vehicle detection and reprogramming traffic signal timing.

The Contractor shall contact the Engineering Manager, Bob Critchfield at (909) 291-2946, at least two working days prior to commencement of work, for approval of proposed striping layout.

The Contractor shall contact the Street Maintenance, at (909) 291-2930, at least two working days prior to painting pavement markings, for approval of stencils.

The Contractor shall contact the Water Division, Mark Warner, at (909) 912-4416, at least two working days prior to commencing work relating to potable water.

**The Contractor shall notify the City arborist prior to any tree and/or tree root removals. The Contractor shall give (approximately two weeks) advance notice to allow for arborist scheduling. The Contractor shall shave/cut/prune tree roots as recommended by the arborist to protect any trees which are scheduled to remain and be protected in place.**

**Upon completion of the root pruning/shaving operation, the Contractor shall resume concrete construction operations. Contractor shall clear areas from any root shavings, prepare subgrade, and make grades for the proposed concrete improvements. In order to maintain access for the residents, all driveways shall be constructed one half at a time, or at the option and sole expense of the Contractor and upon approval by the Engineer, a "high early" strength concrete may be used, so that 3 hours after the placement of concrete, the new driveway, with steel plates placed over it, shall be capable of withstanding the imposed vehicle loading without damage to the new concrete.**

### **1.4.2 Underground Service Alert**

The Contractor shall contact Underground Service Alert at least two working days prior to excavating. The Contractor shall notify Underground Service Alert by calling 811 to assist in the location of underground utilities.

### **1.4.3 Refuse Collection and Street Sweeping Services**

The Contractor shall notify Burrtec Waste Industries at (909)-949-0500 for trash pickup in advance of the work or any partial street closure so that trash will be picked up on time. In accordance with Part 6 "Temporary Traffic Control" – Section 600, "Access," of the SSPWC, it shall be the Contractor's responsibility to see that trash is picked up within the limits of the job.

Residential street sweeping in the City of Upland is performed by Clean Street, through contract with Burrtec Waste Industries, Inc. The Contractor shall notify Burrtec Waste Industries at (909)-949-0500 at least 48 hours prior to the beginning of work, in order to coordinate the work with the street sweeping operations in the area.

### **1.4.4 Other Utility Companies and Agencies**

The Contractor shall notify all utility companies who have facilities, (vaults, valves, etc.), on the street to be resurfaced in order that they may schedule their work accordingly in adjusting their vaults or valves to the new grade. The Contractor may be required to assist them during their adjusting operation.

The Contractor will be required to cooperate with the delivery of mail and to maintain existing schedules for the services.

The Contractor shall coordinate with public transit operating in the area to plan and to accommodate bus routes and passengers at least five (5) working days prior to commencement of any work which will involve any of their facilities. Temporary bus stops shall be maintained to accommodate bus passengers and buses.

Full compensation for satisfying the requirements of coordination with other agencies and utilities shall be considered as included in the appropriate bid item and no additional compensation will be allowed therefor.

## **1.5 Completion and Acceptance**

### **1.5.1 Guarantee of Work and Materials**

The Contractor shall guarantee that all work performed by him under this contract fully meets the requirements thereof as to quality of workmanship and materials furnished. If any defects in materials or workmanship become evident within a period of one (1) year from the date of acceptance of the work by the City Council, the Contractor shall, at his own expense, make any repair or replacement necessary to restore the work to full compliance with these Special Provisions, including repair of settled backfill and resurfacing.

Such repair and replacement shall be made promptly upon receipt of written notice from the City. If the contractor fails to make such repair and replacement promptly, the City may cause the work to be done and the cost incurred thereby shall become the liability of the Contractor and his surety.

If, in the opinion of the Engineer, defective work creates a dangerous condition or requires immediate attention to prevent further loss to the City or to prevent interruption of operations of the City, the City will attempt to give the notice required by this article.

If the Contractor cannot be contacted or does not comply with the Engineer's request for correction within a reasonable time as determined by the Engineer, the City may, notwithstanding the provisions of this article, proceed to make such correction and the costs of such correction shall be charged against the Contractor. Such action by the City will not relieve the Contractor of the guarantees provided in this article or elsewhere in this contract.

This article does not, in any way, limit the guarantee on any items for which a longer guarantee is specified or on any items for which a manufacturer gives a guarantee for a longer period, nor does it limit other remedies of the City in respect to latent defect, fraud, or implied warranties. Contractor's bonds shall remain in force during the warranty period.

Payment for fulfilling the requirements of this section shall be considered as included in the prices for the various Contract items of work, and no additional compensation will be allowed therefore

### **1.5.2 Liquidated Damages**

Liquidated Damages shall be in the amount of ***Two Hundred and Fifty Dollars, (\$250)*** per calendar day in excess of the time allowed under this Contract. This amount shall be deducted from any compensation due the Contractor should he fail to complete the work required by the terms of his contract within the time specified herein, plus any authorized time extension.

## **1.6 Construction Start Date and Time of Completion**

The City is anticipating award of the Construction Contract in **July, 2024**. Contractor shall execute all required documents in an expeditious manner (i.e. Agreement, Insurance, Bonds, etc.) so that construction can begin no later than three weeks after the award of bid. The Contract Time shall commence on the date of issuance of the City's written Notice to Proceed (NTP). The Contractor undertaking the work hereinafter specified will be required to complete all work within **Forty-Five (45) calendar days** following date of issuance of the City's written NTP. The **Forty-Five (45) calendar days** shall include lead time for the manufacture / order of material required on this project.

The Contractor shall submit to the City for approval, a construction schedule at least 10 days prior to starting work.

## **1.7 Work Hours**

Permitted work hours shall be 7:00 a.m. to 3:30 p.m., Monday through Friday. The Contractor shall take all necessary steps to minimize inconvenience to residents, businesses, and the public.

Work in excess of eight (8) hours per day, on Saturdays, Sundays, or legal holidays, requires prior consent of the City Engineer and is subject to Cost of Overtime Construction Inspection. Should the Contractor desire to perform work during these periods, he must submit his written request to the City Engineer at least forty-eight (48) hours prior to the anticipated start of such work. No work outside the permitted work hours stated above shall proceed without the approval of the City Engineer.

## **1.8 Notification of Residents and Businesses**

All adjacent homeowners, business owners, and occupants shall be duly notified by the Contractor, in writing, of his proposed operation. Notice shall be delivered at least ten (10) working days prior to the start of construction. The City will provide the notification letter, and any necessary attachments, and the Contractor shall be responsible for reproduction and distribution of such notification letter and attachments.

Renotification will be required if the Contractor's schedule is altered or other delays occur, which significantly affects the scheduled work. Renotification shall be at the Contractor's expense.

Prior to the actual start of the operation the Contractor shall inform the residents, tenants, business owners or occupants regarding the construction to preclude entrapment of cars and vehicles in driveways, garages, or parking areas. All costs involved in notification of residents and businesses shall be included in the various contract items of work and no additional compensation will be allowed therefore.

## **1.9 Temporary Traffic Control**

Temporary Traffic controls (TTC), including but not limited to vehicular and pedestrian traffic controls, maintenance of vehicular and pedestrian access, detours and street closures, shall be in accordance with the latest edition of Manual of Traffic Controls for Construction and Maintenance Work Zones, as published by the Department of

Transportation of the State of California; California Manual on Uniform Traffic Control Devices (CA MUTCD); Part 6, "Temporary Traffic Control," of the SSPWC, and the following Special Provisions. In the event of conflict, the Special Provisions shall take precedence over the Manual of Traffic Controls, and the Manual of Traffic Controls shall take precedence over the Standard Specifications.

The contractor is also advised of City of Upland Ordinance 1495 for other specific street closure requirements. **Contractor shall prepare and submit for approval a traffic control plan prepared by a registered engineer for all project work. Construction will not be allowed to begin until traffic control plan is accepted by the City.**

### 1.9.1 General Requirements

1. The CONTRACTOR **shall furnish and maintain during the duration of the project, Portable Changeable Message Signs (CMS) suitable for both daylight and night time operations** under varying climatic conditions; i.e., visibility for speed control, advisories on alternate routes, and general traffic management during all working shifts, as directed by the Engineer. The CMS for this project shall be installed at the project approaches or locations designated by the Engineer. **CMS signs shall be installed at least 10 calendar days in advance of the beginning of construction.**

The CMS shall be in accordance with Section 12-3.32, "Portable Changeable Message Signs," of the Caltrans Standard Specifications.

After initial placement, portable changeable message signs shall be moved from location to location as directed by the Engineer and maintained in operable condition throughout the duration of the project.

2. Contractor shall have exclusive control and responsibility for traffic control and safety devices, all signage and roadway markings, all equipment and materials, and the ongoing construction at all times.
3. The Contractor shall conduct his operations so as to offer the least possible obstruction and inconvenience to the public, and shall have under construction, no greater length or amount of work than can be prosecuted properly with due regard to the rights of the public. The Contractor's operations will cause no unnecessary inconvenience. The access rights of the public will be considered at all times.
4. The Contractor shall furnish and maintain all construction signs, channelizing devices, barricades, k-rail, temporary traffic striping and pavement markings, lighting devices, etc., to safely guide the traffic through the project limits, as described herein, and as directed by the Engineer.
5. The Contractor will be responsible for obtaining all partial street closure permits from the City of Upland prior to the start of any work. The street closure permits will identify additional signing requirements, work hours and other conditions as may be necessary to minimize inconvenience to motorists and businesses.

**Ingress and egress to local residents, commercial and industrial properties must be accessible at all times.**

6. All traffic control and safety devices, equipment and materials, including but not limited to cones, delineators, flashing warning lights, barricades, high level warning devices (flag trees), flags, signs, markers, portable barriers, flashing arrow signs, markings and flagging equipment, shall be provided and maintained in "like new" condition.
7. The Contractor shall furnish and properly install, construct, erect, use and continuously inspect and maintain, twenty-four (24) hours per day, seven (7) days per week, all said devices, equipment and materials, and all temporary and permanent pedestrian and driving surfaces as necessary to provide for the safety and convenience of and to properly warn, guide, control, regulate and channelize project workers and the public beyond said limits as necessary to include areas affecting or affected by the work, from the start of work to the completion of the work.
8. High level warning devices (flag trees) are required at all times for any work being performed within the roadway, unless otherwise specifically authorized by the City Engineer. Flashing arrow boards will be required on all streets with four or more lanes, or as deemed necessary by the Engineer or Inspector.
9. All barricades shall be equipped with flashing warning lights and all traffic cones shall be no less than 28 inches in height except that shorter cones, 12 inches high or higher, may be used during striping maintenance operations where the only function of the cones is to protect the wet paint from traffic.
10. Contractor shall have exclusive control and responsibility for all flaggers at all times. Properly trained and experienced flaggers shall be provided at all times when Contractor's operations encroach into the public right of way. Flaggers shall also be provided to direct traffic when said traffic is to be interrupted, when two-way traffic is to be reduced to one-way traffic at such time as is necessary to safely pass the traffic through or around the work area, and when so directed by the City.
11. Any traffic control and safety devices and equipment being used which becomes damaged, destroyed, faded, soiled, misplaced, worn out, inoperative, lost or stolen shall be promptly repaired or refurbished and/or replaced, and any traffic control and safety devices and equipment being used which are displaced or not in an upright position from any cause, shall be promptly returned or restored to their proper position.
12. Contractor shall have exclusive control and responsibility for all signs and warning devices, and all trucks, equipment and materials at all times. An unobstructed view of all signs and warning devices including, but not limited to, stop signs, stop ahead signs, street name signs and other regulatory, warning and construction signs, markers and warning devices shall be maintained at all times. No trucks or other equipment or materials shall be stopped, parked or otherwise placed in such a manner as to block signs from the view of vehicular and/or pedestrian traffic to which it applies.
13. When entering or leaving roadways carrying public traffic, the Contractor's equipment, whether empty or loaded, shall yield to said public traffic at all times,

except where the traffic is being controlled by Police officers, Fire officers, or at traffic signalized intersections or the aforementioned construction traffic signal.

14. Contractor shall have exclusive control and responsibility for stockpile and/or storage areas at all times. Stockpiling and/or storage of materials on any public right of way or parking areas, or immediately adjacent to all such areas, will not be allowed without specific permission of the City. Materials spilled along or on said right of way or parking area shall be removed completely and promptly. All stockpile and/or storage areas shall be kept in a safe, neat, clean and orderly fashion, and shall be restored to equal or better than original condition upon completion of the work.
15. On projects involving work on, closure of or partial closure of existing streets and where vehicular access to the abutting property must be restricted, the work shall be so selected, arranged and scheduled that the persons requiring access to said abutting property and/or residents along said streets affected will be able to park within a reasonable distance of not more than 500 feet from their homes and/or destination; and in addition, no two (2) adjoining streets shall be closed at the same time, except as otherwise authorized by the City.
16. When work has been completed on a particular street or has been suspended or rescheduled and said street is to be opened to vehicular traffic, all equipment, "NO PARKING" signs, other obstructions and unnecessary traffic control devices and equipment shall be promptly removed from the street, except as otherwise authorized or directed by the City Engineer. Temporary traffic striping shall be applied prior to opening any newly paved area to traffic. This includes lane and centerlines.
17. Should the Contractor be neglectful, negligent or refuse, fail or otherwise be unavailable to promptly, satisfactorily and fully comply with the provisions specified and referred to hereinabove, the City reserves the right to correct and/or mitigate any situation, which in the sole opinion of the Engineer constitutes a serious deficiency and/or serious case of noncompliance, by any means at its disposal at the Contractor and/or permittee's expense, and in the case of a contract City project, to deduct the cost therefore from the Contractor's progress and/or final payments. Such corrective actions taken by the City shall not reduce or abrogate the Contractor's legal obligations and liability for proper traffic control and safety measures and shall not serve to transfer said obligations and liability from the Contractor to the City or the City's agent.
18. Violations of any of the above provisions and/or provisions of the referenced publications, unless promptly and completely corrected to the satisfaction of the Engineer, shall, at the sole discretion of the City, be grounds for termination of the Contract or shut down or partial shutdown of the work without compensation to the Contractor and/or permittee, or liability to the City, all as prescribed by contractual obligations or State law, whichever is applicable.

### **1.9.2 Pedestrians**

1. A minimum walkway of 48 inches in width must be maintained at all times for safe pedestrian passage through all parkway work areas. Crosswalks shall remain unobstructed at all times. Obstructions within the walkway areas shall be illuminated during the hours of darkness and marked with Type II barricades

with flashing warning lights.

2. Where construction prohibits pedestrian access, alternate crossing areas shall be established with appropriate signing and other devices as required by the Engineer. Pedestrian access facilities shall be provided through construction area within the right-of-way. Pedestrian walkways shall be provided with surfacing as required to maintain safe and accessible pathways. Surface shall be skid resistant and free of irregularities.
3. The Contractor shall keep the areas adjacent to the project site clear of any objects that may be hazardous to pedestrians and motorists. Provisions to reroute pedestrians, including the disabled, around the work area must be clearly delineated and maintained. If the Contractor's operations require the closure of a walkway, then another walkway shall be provided nearby, off the traveled roadway, along the general path of travel.

### **1.9.3 Temporary Surfacing**

1. Temporary A.C. paving shall be placed and maintained at locations determined by the Engineer wherever excavation is made through pavement, sidewalk or driveways, in accordance with Section 306-13.1 "Temporary Resurfacing" of the SSPWC.
2. The Contractor shall maintain the temporary surfacing throughout the duration of the project until permanent pavement has been restored.

### **1.9.4 Steel Plating**

The Contractor shall furnish, install and maintain steel plates as necessary to obtain minimum lane requirements specified herein and/or to maintain access to private property.

1. Steel trench plates shall be employed to bridge across open excavations and newly poured concrete (if applicable). The Contractor shall be responsible to ascertain the appropriate size and placement of the steel plates and other devices to support vehicular traffic loading across open excavations and newly poured concrete without sustaining damage to the new improvements.
2. **All steel plates shall be recessed into the roadway and shall be textured for skid-resistance. Steel plates shall be secured in place to prevent their movement, sliding or shifting. If more than one steel plate is used, plates shall be tack welded to prevent slippage.**

### **1.9.5 Pavement Transitions**

The Contractor shall construct pavement transitions at all lateral and transverse join lines, created by trenching, base paving, temporary paving or any combination of each. A vertical drop-off or step between the lateral edges of the pavement under construction and the adjacent pavement shall not be permitted during non-working hours.

### 1.9.6 Driveways

Vehicular access to driveways shall be maintained at all times, except when necessary construction precludes such access for temporary periods, as follows:

1. Driveway approaches shall be poured within 48 hours of the adjacent curb and gutter.
2. Curb and gutter shall be poured within 24 hours from the time access is blocked by formwork.
3. Driveway approaches shall cure for three days before being reopened to vehicular access.
4. Driveways shall not be closed over weekends, except for curing of concrete.
5. Driveways closed due to placement of bituminous pavement shall be reopened as the new pavement has cooled sufficiently to carry the traffic without damage.
6. The Contractor shall notify all residents and businesses at least 72 hours in advance of driveway closure.
7. During the time driveways are closed, a minimum of two Type II barricades with flashing warning lights shall be used to affect the closure.
8. Driveways shall be kept open at all other times, and if necessary, temporary A.C. ramps and/or steel plates shall be provided.
9. When it becomes necessary to block access to driveways for a short period of time during construction, the Contractor shall notify the affected property owners/occupants 48 hours in advance of such driveway closure. The Contractor shall facilitate work in front of driveways so that these driveways may be opened for use immediately.

### 1.9.7 Parking

On-street parking may be restricted within the project limits. Temporary "NO PARKING – TOW AWAY" signs shall be provided and posted by the Contractor not less than forty-eight (48) hours in advance of the start of construction.

### 1.9.8 Street Lighting

1. The Contractor shall maintain illumination of the traveled roadway after hours of darkness throughout the duration of the project, as follows:
2. The street lighting system shall be installed and removed in phases such that not less than one-half of the street lights are operable each evening.
3. A minimum illumination level of 0.4 foot-candles with a 6:1 uniformity ratio shall be provided, unless otherwise approved by the Engineer.

### 1.9.9 Lane Closures

The Contractor shall comply with the following general lane closure requirements:

1. Flashing arrow signs (sequential arrow boards) shall be utilized for all closures of through travel lanes on **Arrow Highway and all cross streets (i.e. Fairwood Way), where applicable**, as designated or directed by the Engineer.

2. Left turns shall be maintained at all times to the fullest extent possible. Under extenuating circumstances and when permitted by the Engineer, left turn lanes may be closed with R-17, "NO LEFT TURN" signs placed both at the beginning and end of each left turn lane closed.
3. Right turns shall be maintained at all times to the fullest extent possible. When permitted by the Engineer, right-turn lanes may be closed with R-16, "NO RIGHT TURN" signs placed both at the beginning and end of each right turn lane closed.
4. To allow for equipment movement and cleanup during various construction operations, momentary stoppage of traffic and turn movements will be permitted, using flagging procedures.

#### **1.9.10 Road Closures**

Road closures shall be prohibited unless explicitly approved by the Engineer.

#### **1.9.11 Temporary Striping**

The Contractor shall provide temporary traffic restriping at the conclusion of any working day for any centerline, crosswalks or lane line which is obliterated by construction.

#### **1.9.12 Shutdowns**

1. Traffic signal shutdowns shall be restricted to two hours maximum during one 24-hour period. All signal work, including but not limited to shutdowns, shall require coordination and/or approval by the City Engineer.
2. Where traffic signal shutdowns are required, the Contractor shall furnish and install temporary stop signs for each travel lane at 24"x24" in size securely mounted and placed in clear view to all approaching traffic. Stop signs shall be placed pursuant to Section 86-1.06 of the Caltrans Standard Specifications.
3. The presence of two uniform police officers to direct traffic during shutdown period is required during any peak hour work and as directed by the Engineer. All related expenses and wages of the police officers shall be borne by the Contractor.
4. The Contractor shall provide the Engineer five (5) working days advance notice prior to any traffic signal shutdown for the purpose of scheduling police traffic control. All shutdowns shall be scheduled pursuant to Section 86-1.06 of the Caltrans Standard Specifications. No signal shutdowns will be allowed on Fridays.

#### **1.19.13 Emergency Response**

The Contractor shall provide the Engineer with names and telephone numbers of at least three people responsible for emergency service response. Upon notification, Contractor shall respond to City emergency requests. In the event these people do not promptly respond when notified, or it becomes necessary to call other forces to

accomplish emergency service, the Contractor will be held liable for any costs incurred. A fee of \$400/hour, at 4 hours minimum, will be charged to the Contractor.

1. During Working Hours:

In case of an emergency that threatens loss or injury of property, and or safety of life during working hours, the Contractor shall act, without previous instructions from the City, as the situation may warrant. He/She shall notify the Engineer of the emergency and the action taken immediately thereafter. Any compensation claimed by the Contractor, together with substantiating documents in regard to expense, shall be submitted to the Engineer within 15 calendar days after the emergency. Compensation, if allowed, will be paid for as extra work.

2. Outside of Working Hours:

Whenever, in the opinion of the City, an emergency arises outside of the regular working hours which threatens loss or injury of property, or danger to public safety, the Contractor shall act, without previous instructions from the City as the situation may warrant. He/She shall notify the Engineer of the emergency and the action taken immediately thereafter. Any compensation claimed by the Contractor, together with substantiating documents in regard to expense, shall be submitted to the Engineer within 15 calendar days after the emergency. Compensation, if allowed, will be paid for as extra work.

In the event the Contractor is unable to respond to an emergency outside of regular working hours, the City's forces will handle such emergency work. If such emergency arises out of, or is the result of, operations by the Contractor, the cost of the corrective measures will be billed to the Contractor and deducted from his/her payment as provided in the Contract documents. The performance of emergency work by City forces will not relieve the Contractor of any of his/her responsibilities, obligations, or liabilities under the Contract.

### **1.10 Storage of Materials and Equipment**

The storage of materials and equipment will not be allowed on public streets or in the public right of way unless prior arrangements have been made with the Engineer. The Contractor shall be responsible for obtaining a storage site at the Contractor's sole expense. The Contractor shall provide the City with a copy of the written permission from the property owner for the use of the site if the property is not owned by the Contractor or the City.

### **1.11 Safeguarding of Equipment, Materials, and Work**

The Contractor shall properly safeguard all equipment, materials, and work against loss, damage, malicious mischief, or tampering by unauthorized persons until acceptance of the work by the City. Locked and covered storage or continuous surveillance by a watchman shall be provided by the Contractor if required to accomplish this task.

### **1.12 New Materials and Equipment**

Unless otherwise specified, shown, or permitted by the Engineer, all materials and equipment incorporated in the work shall be new and of current manufacture. The Engineer may request the Contractor to furnish the manufacturer's certificates to this effect.

### **1.13 Material Testing**

All tests of materials furnished by the Contractor shall be made in accordance with commonly recognized standards of national organizations and such special methods and tests as are prescribed in these specifications.

No materials shall be used until they have been approved by the Engineer.

The Contractor shall at his expense furnish the City, in triplicate, certified copies of all required factory and mill test reports. Any materials shipped by the Contractor from a factory or mill prior to having satisfactorily passed such testing and inspection by a representative of the City shall not be incorporated in the work, unless the Engineer shall have notified the Contractor, in writing, that such testing and inspection will not be required.

At the option of the Engineer, the source of supply of each of the materials shall be approved by the Engineer before delivery is started and before such material is used in the work.

All soil and material testing lab/firm shall be approved by the Engineer prior to start of construction. Any subsequent soil and material tests deemed necessary due to the failure of initial tests will also be at the Contractor's sole expense.

All materials furnished and all work performed under the Contract shall be subject to inspection by the Engineer. The Contractor shall be held strictly to the true intent of the Specifications and Drawings in regard to quality of materials, workmanship, and diligent execution of the Contract. Such inspection may include mill, plant, shop, or field inspection as required. The Engineer shall be permitted access to all parts of the work, including plants where materials or equipment are manufactured or fabricated. The Engineer shall be furnished with such materials, information, and assistance by the Contractor, subcontractors, and suppliers as is required to make a complete and detailed inspection.

The Engineer will make, or have made, such tests as he deems necessary to assure that the work is being accomplished in accordance with the requirements of the Contract. In circumstances where it is suspected that proper procedures and/or materials are not being followed or used, any testing required by the Engineer shall be at the Contractor's expense. It is understood and agreed that the making of tests shall not constitute an acceptance of any portion of the work nor relieve the Contractor from compliance with the terms of the Contract.

## **1.14 Order of Work**

The Contractor shall be responsible for performing all work in accordance with the requirements of the Plans and Specifications and in the order indicated on his approved schedule of work.

At least ten days prior to starting work, the Contractor shall submit to the Engineer for approval, a construction schedule, in accordance with Section 6-1.1, "Construction Schedule," of the SSPWC. The progress schedule shall be consistent in all respects with the time and order of work requirements described in these Special Provisions.

### **1.14.1 Protection of Utilities**

The Contractor's attention is directed to Section 402, "Utilities," of the Standard Specifications for Public Works Construction (SSPWC).

The Contractor will take due precautionary measures to protect the utilities shown and other utilities or structures not shown on these plans that might be discovered during the process of the job.

The City of Upland Water Operations Division has water facilities, (service laterals, water meters, valves, etc.) within the vicinity of the project. The Contractor shall protect existing facilities that are not to be removed.

Where water valve boxes or other utility facilities are encountered in areas designated for removals and reconstruction, the Contractor shall protect those boxes and facilities in place. Meter boxes shall be raised to grade where parkway improvements are reconstructed as shown on the plans. Payment for protection of utilities shall be considered as included in various items of work and no additional compensation will be allowed therefor.

In the event that a water service is damaged, the Contractor shall notify the Water Operations Division and the Engineering Division immediately. The Contractor shall also arrange for the immediate repair of the water service by a licensed plumbing contractor, at no cost to the City. In certain circumstances, the Contractor may encounter water services which are entangled in roots. In these circumstances, it may be necessary to replace the water service. All such replacements shall be made by qualified personnel. In order to receive compensation for this repair, the City Tree Inspector shall be contacted prior to any further root removals.

When a water pipe crosses a sanitary sewer pipe, where minimum vertical separation is not met, concrete pipe encasement shall be provided by the Contractor.

Full compensation for compliance with the provisions specified and referred to hereinabove shall be considered as included under the water work Bid Items, and no additional compensation will be allowed therefor.

### **1.14.2 Protection of Work**

The provisions of Section 4 "Control of Materials" of the SSPWC shall apply except as modified and supplemented below:

The Contractor shall provide sufficient personnel, barricades, delineators, and ribbon at each location to adequately protect the new and fresh concrete surfaces from vandalism and unauthorized markings. Newly poured and finished concrete areas shall be delineated or cordoned off with tape to inhibit and discourage pedestrians, bikers, and skateboards from tracking across the fresh sidewalk surfaces.

Unauthorized markings (i.e., graffiti, footprints, bike tire marks, and scuff marks) in the new sidewalk surfaces are not acceptable and may be cause for rejection. All such areas rejected due to such cause shall be removed and replaced at the Contractor's expense.

All costs for protecting the new concrete surfaces and any graffiti removal shall be included in contract unit price bid for the various Bid Items of work involved, and no additional compensation will be allowed therefor.

### **1.14.3 Obstruction and Cooperation with Other Work**

A minimum of two (2) working days prior to construction, the Contractor will expose all known utility crossings in order to provide for grade and alignment adjustments, if necessary. All costs involved in exposing existing utilities shall be included in the various contract Bid Items of work and no additional compensation will be allowed therefor unless called out otherwise.

The Contractor will schedule his work and cooperation with all other forces working in the area so that all improvements in the project area may be installed in a logical, workmanlike manner. The Contractor will take due precautions to protect all improvements placed by others in the vicinity of their operations.

**The Contractor shall also coordinate with Burrtec for trash pickup in advance of the work or street closure so the trash will be picked up on time.**

**The Contractor shall notify the City arborist prior to any tree and/or tree root removals. The Contractor shall give (approximately two weeks) advance notice to allow for arborist scheduling. The Contractor shall shave/cut/prune tree roots as recommended by the arborist to protect any trees which are scheduled to remain and be protected in place.**

**Upon completion of the root pruning/shaving operation, the Contractor shall resume its concrete construction work. Contractor shall clear areas from any root shavings, prepare subgrade, and make grades for the proposed concrete improvements. In order to maintain access for the residents, all driveways shall be constructed one half at a time, or at the option and sole expense of the Contractor and upon approval by the Engineer, a "high early" strength concrete may be used,**

**so that 3 hours after its pour, the new driveway, with steel plates over it, shall be capable to withstand the imposed load without damage.**

#### **1.14.4 Trees**

The provisions of Sections 300-1 "Clearing and Grubbing" of the SSPWC shall apply except as modified and supplemented below:

**Prior to removal of the sidewalk and curb & gutter, the contractor shall coordinate with the City's Arborist to inspect tree roots prior to cutting or pruning the roots. Contractor shall give minimum of two-week advance notice to the Arborist to inspect the tree roots.**

Existing tree roots shall be removed within the areas where existing curb and asphalt concrete pavement are to be removed and reconstructed, to a depth of 8 inches below subgrade or as directed by the Engineer. Limits of tree root removal shall extend to 6 inches back of curb where at that point, roots shall be cut so that the remaining root ends have a neat, smooth surface. Contractor shall not backfill behind curb until the above-mentioned root treatment has been inspected by the Public Works Inspector.

#### **1.14.5 Sprinkler Systems and Landscaping**

The provisions of Section 400, "Protection and Restoration" of the SSPWC shall apply except as modified and supplemented below:

Sprinkler Systems: The Contractor shall be responsible for cutting, capping, and repairing in kind, and/or protecting in place any existing sprinkler systems within the work area under this contract. When any irrigation lines or improvements are damaged through the course of construction, these lines, sprinklers, or other components shall be replaced with City approved like materials and shall be in working order when work is completed. All irrigation systems shall be in proper operating condition within two (2) days of becoming inoperable.

The Contractor, in writing, shall notify impacted residents and/or property owners to inspect their sprinkler system to determine if any damage was caused due to the construction. The notice shall be done within three (3) days of completing the project, and shall request that the residents and/or property owners notify the Project Manager of such condition within seven (7) days. The seven (7) days notification is only a courtesy request and not a requirement; any damaged irrigation reported after the seven (7) days will still be required to be repaired by the Contractor.

If the Contractor fails to repair an irrigation system within the time stated, the City will withhold the anticipated cost of repair of the damaged irrigation system from the progress payment. Any additional work, whether repair or new construction, which is requested by the property owner, shall be fully compensated by the Contractor and the City will not be responsible for additional compensation for this work.

All sprinkler heads shall be salvaged and reused in the same location, if still in working

condition. If heads are not reusable, they shall be replaced with a like type. Prior to construction, the Contractor is encouraged to document, in writing and by photograph, any existing damage such as broken or missing sprinkler heads, within the project area.

Landscaping: All damaged grass or shrubs shall be replaced in kind or better within two (2) weeks of the damage. It is the Contractor's responsibility to match the existing grass with a similar variety. **Seed is not acceptable in lieu of sod.** Any area, which is rutted, shall be leveled with appropriate topsoil and sod.

The Contractor, in writing, shall notify impacted residents and/or property owners to inspect their lawn to determine if any damage was caused due to construction. The notice shall be done within three (3) days of completing the project, and shall request that the residents and/or property owners notify the Project Manager of such condition within seven (7) days. The seven (7) days notification is only a courtesy request and not a requirement; any damaged irrigation reported after the seven (7) days will still be required to be repaired.

If the Contractor fails to repair landscaped areas within the time stated, the City will withhold the anticipated cost of repair of the damaged landscaped areas from the progress payment. Any additional work, whether repair or new construction, which is requested by the property owner, shall be fully compensated by the Contractor and the City will not be responsible for additional compensation for this work.

Restoration of landscaped parkways shall conform to Section 212, "Water and Sewer System Valves and Appurtenances" and Section 306, "Open Trench Conduit Construction" of the SSPWC.

**Prior to construction, the Contractor shall inspect the entire project area and document in writing and/or by photograph, any pre-existing condition. Existing damage to improvements within the project area shall be reported to the Inspector for verification.**

### **1.15 Changes in Work**

The City reserves the right to make such alterations, deviations, additions to or omissions from, the Plans and Specifications, including the right to increase or decrease the quantity of any item or portion of the work to match the funding available for the project, or to omit any item or portion of the work, as may be deemed by the Engineer to be necessary or advisable, and to require such extra work as may be determined by the Engineer to be required for the proper completion or construction of the whole work contemplated.

### **1.16 Suspension of Work**

The Engineer acting on behalf of the City may, by written notice to the Contractor, suspend the work in whole or in part for such period or periods as the Engineer may deem

necessary, due to unsuitable weather, delay in delivery of City-furnished equipment or materials, or such other conditions as are considered unfavorable for prosecution of the work, or failure on the part of the Contractor to carry out the provisions of the Contract or to provide materials or workmanship meeting the requirements of the Specifications. Suspended work shall be resumed by the Contractor within 10 calendar days of receipt from the Engineer of written Notice to Proceed. The Contractor shall have no claim for damages alleged to have been suffered by reasons of any suspension of the work without termination of the Contract, and Contractor shall receive no additional compensation because of any such suspension.

#### **1.17 Use of Completed Portions**

The City shall have the right to take possession of and use any completed or partially completed portions of the work, notwithstanding the time for completing the entire work or such portions as may not have expired; but such taking possession and use shall not be deemed an acceptance of the work not completed in accordance with the Contract Documents.

#### **1.18 Failure to Comply**

If the Contractor should refuse or neglect to comply with the provisions of the Contract or the orders of the Engineer, the City

may have such provision or orders carried out by others at the expense of the Contractor.

#### **1.19 Noncompliance with Plans and Specifications**

Failure of the Contractor to comply with any requirement of the Specifications and Drawings, or failure to immediately remedy any noncompliance upon notice from the Engineer, may result in suspension of contract progress payments. Any progress payments so suspended shall remain in suspension until the Contractor's operations are brought into compliance to the satisfaction of the Engineer in accordance with the Contract Documents and Specifications. No additional compensation will be allowed as a result of suspension of progress payments due to Contractor's noncompliance with the Plans and Specifications.

#### **1.20 Site Access**

The City Engineer or his representative, testing agencies, and government agencies with jurisdictional interests shall be allowed access to the Work at all times for their observation, inspection, and testing. The Contractor will provide proper and safe conditions for such access.

#### **1.21 Construction Water**

The Contractor shall be responsible for furnishing all necessary water for compaction, cleaning, flushing, dust control, etc. The Contractor shall obtain a hydrant meter from the City of Upland if the Contractor intends to use city water. The Contractor will not be allowed to use water from individual residences or businesses. The cost of obtaining a hydrant meter from the City and the usage of the water is considered incidental to the job and shall be included in contract unit prices bid for the various items of work involved. No additional compensation will be allowed therefor.

City does not expressly or by implication; guarantee that water will be available for construction use. The City reserves the right to cease delivery of water for construction use should the need arise. Contractor will not be compensated for any damages or delays as a result of the unavailability of construction water.

## **1.22 Safety**

All Construction will be performed in compliance with the standards as established by OSHA and in accordance with the appropriate State of California regulations, including SCRRRA requirements in the vicinity of railroad crossings. It will be the Contractor's responsibility to acquaint himself and abide by these regulations during all phases of construction. The Contractor will hold harmless and indemnify the City and its agents for any damages caused by failure to abide by said regulations.

## **1.23 Engineer's Estimate**

The quantities of work to be done and materials to be furnished are approximate as shown and listed in these Specifications and are given as a basis of comparison of bids only. The City does not expressly or by implication agree that the actual amount of work will correspond therewith.

## **1.24 Shop Drawings**

The Contractor shall furnish and receive a reviewed copy of a submittal prior to bringing materials onsite. Submittals shall be 3 copies of detail drawings, catalog sheets, cuts or descriptive lists of all material to be used on the job. The submittals shall include the name and location of the supplier and manufacturer, trade name, catalog reference, size, finish, and all pertinent data, and shall be reviewed by the City within 10 working days and returned marked with one of the following:

- 1) NO EXCEPTIONS TAKEN
- 2) MAKE CORRECTIONS NOTED
- 3) REVISE AND RESUBMIT
- 4) REJECTED

## **1.25 Record Drawings (As-Built Drawings)**

The Contractor shall maintain, on the job site, a set of full-size reproducible contract drawings, or a set of full-size blue-line or black-line prints. On these he shall mark all as-built conditions, locations, configurations, and other details, which may vary from the details represented on the original drawings. This master record of as-built conditions, including all revisions made necessary by addenda, change orders, and the like, shall be maintained up-to-date during the progress of the work.

On a monthly basis, the Contractor shall submit progress record drawing(s) clearly delineating the improvements completed, for the purpose of review and processing progress payments. The City's ability to process the progress payments is contingent upon the timely submittals of the progress record drawing(s).

Upon completion of the work and prior to final acceptance, the complete set of contract drawings (size D, 24x36 in.), marked-up to show all as-built conditions, shall be delivered to the Engineer. These drawings shall be known as "Record Drawings".

## **1.26 Final Cleanup**

Prior to final acceptance, the Contractor shall restore the entire project site to a condition equal or better than the pre-construction condition as evidenced by film, notes, sketches and other construction records.

### **1.26.1 Cleaning and Dust Control**

Clean-up and dust control shall conform to Section 7-8, "Work Site Maintenance," of the SSPWC. During execution of work, the Contractor will daily clean the site, adjacent properties, and public roads, and dispose of waste materials, debris, and rubbish to assure that all affected properties and roadways are maintained free from accumulations of water, materials and rubbish. Watering for dust control shall consist of developing a water supply and furnishing and placing all water required for dust control.

Contractor will provide containers for collection and disposal of waste materials, debris, and rubbish.

Contractor will cover all loads of excavated material leaving the site or of material being imported, to prevent excessive dust from being created.

### **1.26.2 Cleanup**

At the end of each day, Contractor shall be responsible for the clean-up of all job sites. All job sites must be left in a safe and orderly condition. The Contractor will perform additional clean-up as directed by the Engineer. The cost for all clean-up shall be considered incidental to the cost of the work and no additional compensation will be allowed therefore.

## **1.27 Permits and Licenses**

### **1.27.1 Construction Permit**

The Contractor will be required to obtain a no-fee Construction Permit from the City prior to issuance of NTP. No compensation for expenses of the Contractor incidental to obtaining the Permits will be allowed or paid for. The Contractor shall comply with the requirements of all City and other public agency permits.

### **1.27.2 Partial Street or Lane Closure Permit**

The Contractor will be required to obtain a no-fee Partial Street or Lane Closure Permit from the City. No compensation for expenses of the Contractor incidental to obtaining the Street Closure Permit will be allowed or paid for. There may be additional restrictions due to a public school within the project area.

### **1.27.3 Excavation Permit**

In accordance with Section 6500 of the Labor Code, the Contractor is required to obtain a permit from the Division of Occupational Safety and Health of the State of California, Department of Industrial Relations for any excavations five feet (5') or

more in depth and into which a person is required to descend. Contractor shall submit a copy of said permit to the Engineer prior to any excavations.

The Contractor shall provide trench shoring systems for the construction of underground improvements, in accordance with Subsections 7-10.4.2, "Safety Orders," and 306-4, "Shoring and Bracing," of the SSPWC and State of California Division of Occupational Safety and Health (Cal/OSHA) Construction Safety Orders.

Excavations five feet or more in depth shall be shored to provide support for existing improvements and protection of workers during trench excavation and pipe placement.

Prior to commencement of work, the Contractor shall obtain a PERMIT from Cal/OSHA and shall submit to the City for approval a detailed plan, showing the design of shoring, bracing, sloping, or other provisions to be made for worker protection from the hazard of caving ground during trench excavation. Trench shoring systems shall be designed by a Civil or Structural Engineer, registered in the State of California. The shoring plan shall consist of complete engineering calculations together with diagrams and specifications for the components of the shoring system proposed for use. No such plan shall allow the use of shoring, sloping or a protective system less effective than that required by the Construction Safety Orders of the Division of Occupational Safety and Health. Copies of all permits shall be submitted to the City prior to start of work.

The shoring system plan to be submitted to the City for approval, either prepared by an Engineer or drawn from manufacturers or supplier's data or catalogue, must be wet-signed and sealed by a Civil or Structural Engineer, registered in the State of California. All specific items or applicable conditions must be outlined on the submittal.

The State of California Department of Transportation "Trenching and Shoring Manual" dated January 1990 will be used as a guide for plan review and approval.

The Contractor shall not assume that only one type of trench safety system, such as a shield or "trench box", will be adequate for this project. The Contractor shall have an alternate plan for the use of other types of safety systems, such as solid sheeting, should field conditions dictate. The design and calculations of such alternate plan shall be readily available from the Contractor upon request by the City.

Contractor shall be solely responsible for implementation and maintenance of worker's safety and protection systems. It shall also be the Contractor's responsibility to provide adequate shoring for the protection of existing improvements in the vicinity of any excavation, in ADDITION to using the method of shoring which has been approved by the City for the protection of workers (such as shields, sloping the sides of excavations, or other similar methods).

Protection of all existing improvements must be considered in the design of the shoring system, including subsurface utilities. The shoring system must sustain loads imposed by traffic, construction equipment, adjacent structures, or any other surcharge loads.

Excavations less than five feet in depth need not be shored unless they are made at the locations, or in types of soil where hazardous ground movement may be expected.

The Contractor shall be solely responsible for any damages which may result from his failure to provide for adequate shoring to support the excavations under any or all of the conditions of loading which may exist, or which may arise during the construction of the project.

#### **1.27.4 City of Upland Business License**

The Contractor and all sub-contractors are required to obtain City of Upland Business Licenses. The cost for all business licenses shall be the Contractor and/or sub-contractor's responsibility, and no additional compensation will be allowed or paid for.

Effective June 2, 2014, the City's Finance Department will no longer be accepting payments for business license renewals or processing new business license applications. To apply for a City business license, Contractor and subcontractors shall contact HdL Companies at (888) 602-0239 or go to:

UPLAND.HDLCOMPANIES.COM

If you wish to renew a current business license by mail, please remit payments to:  
HdL Companies  
1142 S. Diamond Bar Blvd. #502  
Diamond Bar, CA 91765  
(888) 602-0239

#### **1.27.5 Contractor's License**

Contractor must possess a valid Class "A" (unless a different class is specified on the Notice Inviting Bids) Contractor's License from the California Contractors State License Board at the time of bid. Contractor must maintain the Class "A" license in good standing with the California Contractors State License Board throughout the duration of the project.

#### **1.27.6 South Coast Air Quality Management District (SCAQMD)**

South Coast Air Quality Management District Project guidelines are provided in Appendix "C". Contractor's operations shall be in accordance with all current SCAQMD requirements and laws. The Contractor is responsible for compliance with Fugitive Dust Regulations issued by the Air Quality Management District (AQMD). The Engineer shall have the authority to shut down the operations of the Contractor in the event of non-compliance with AQMD regulations. No compensation or expenses of the Contractor incidental to obtaining AQMD permits, or for adhering to AQMD requirements, will be allowed, or paid for. Any fines or penalties levied by the AQMD shall be the Contractor's sole and complete responsibility.

#### **1.28 Preconstruction Meeting and Weekly Progress Meeting(s)**

The Contractor to whom the contract is awarded shall attend a preconstruction meeting at a location and time set by the Engineer. The Contractor shall meet with the Project Engineer weekly to discuss issues and progress of work.

## 1.29 Protection of Improvements

### 1.29.1 Removals

Removals shall include excavation, removing, hauling, and disposing of all materials to the subgrade elevations indicated on the plans, as required to construct the new roadway improvements. This Bid Item involves sawcut, removal and disposal of all existing improvements required for construction of the project including asphalt concrete, Portland cement concrete, macadam, pavement reinforcing fabric (petromat), slurry backfill, base materials, rock, soils, trees and roots, parkway culverts, and miscellaneous Bid Items (including loose or dumped materials) which are within the grading and excavation section. All roots and stumps shall be removed and/or ground to eight (8) inches below subgrade within the roadway section. The locations and dimensions of excavation areas are as shown on the plans and/or directed in the field by the Engineer. Roadway excavation shall be done in accordance with Subsection 300-2, "Unclassified Excavation," of the SSPWC.

The Contractor shall be responsible for obtaining a suitable disposal site for this excavated material, and pursuant to Subsection 300-2.6 of the SSPWC, shall, upon request, file with the Engineer the written consent of the owner of the property upon which he intends to dispose of such material. No additional compensation will be allowed for special handling, hauling or disposal of any excavated material from the project site.

***The Contractor is advised that the City of Upland geology is an alluvial fan. These soil conditions are such that larger rocks, cobbles, and boulders will be encountered during construction. The Contractor shall be responsible for the removal and disposal of rocks larger than 6" in diameter that are within the limits of excavation, as well as for all costs associated in working with rock cobble and boulder soil conditions.***

Subgrade preparation for the roadway improvements shall be done in accordance with Subsection 301-1, "Subgrade Preparation," of the SSPWC and these Special Provisions.

### 1.29.2 Protection of Existing Improvements

The Contractor shall be responsible for protecting all existing equipment, piping, associated appurtenances, etc. during construction to prevent damage to these items. Any damage caused by the Contractor's actions will be corrected by the Contractor at its expense.

### 1.29.3 Protection of New Improvements

The Contractor shall be responsible for the protection of the new improvements and shall exercise care to adequately protect the new improvements until the work has been accepted by the City.

Any damage caused to the new improvements as a result of the Contractor's actions shall be repaired at the Contractor's expense.

The Engineer may ask the traffic lane or roadway to remain closed if, in his opinion, the street is not yet cured enough to allow traffic on it. The Contractor shall pay all costs associated with any extension of a street closure.

### **1.30 Patents and Copyrights**

The Contractor shall indemnify and save harmless the City and Engineer and their officers, agents, and employees against all claims or liability arising from the use of any patented or copyrighted design, device, material, or process by the Contractor or any of his subcontractors in the performance of the work.

### **1.31 NPDES Requirements**

The Contractor shall conform to the requirements of General Construction Activity Storm Water NPDES Permit No. CAS000002 and Order No. 2009-0009-DWQ issued by the State Water Resources Control Board. This General Permit, hereafter referred to as the "Permit", regulates storm water discharges associated with construction activities.

The Contractor shall also conform to the requirements of NPDES Permit No. CAS6180036 and Order No. R8-2010-0036 issued by the Santa Ana Regional Water Quality Control Board. This permit, hereafter referred to as the "Permit", regulates storm water discharges that enter the City's municipal storm drain systems (MS4). Contractor is not responsible for filing a Notice of Intent (NOI) for Permit coverage or a Notice of Termination (NOT) at project end. City staff will file a NOI for permit coverage and file a (NOT) at the end of the project.

Water pollution control work shall conform to the requirements in the Construction Contractor's Guide and Specifications of the Stormwater Best Management Practice Handbook, dated December 2019, and addenda thereto issued up to and including the date of advertisement of the project, hereafter referred to as the "Handbook". Copies of the Handbook may be obtained from CASQA website at: <https://www.casqa.org/resources/bmp-handbooks>; Telephone: (424) 241-2249; or email at: [CASQA@casqa.org](mailto:info@casqa.org) <mailto:info@casqa.org>. Copies of the Handbook and the Permit are also available for review only, at the City of Upland Public Works Facility.

The Contractor shall become fully informed of, and comply with, the applicable provisions of the Handbook, Permit, and Federal, State, and local regulations that govern the Contractor's operations and storm water discharges from both the project site and areas of disturbance outside the project limits during construction. The Contractor shall maintain a copy of the Permit at the project site, and shall make the Permit available during construction activities.

#### **1.31.1 Storm Water Pollution Prevention**

Storm Water Pollution Prevention shall include control of all waters entering the project site, erosion control, and any dewatering in accordance with California Regional Water Quality Control Board, Santa Ana Region requirements.

Storm, surface, and/or nuisance water may be encountered at various times and locations during performance of the Work. Such waters may interfere with Contractor's operation and may cause damage to adjacent or downstream private

and/or public property by flooding, lateral erosion, sedimentation, or pollution if not properly controlled by Contractor. Contractor, by entering into the Contract, assumes all risk and responsibility for water control. Contractor's responsibility includes, at a minimum, handling any nuisance and/or storm waters that may result during the term of the Contract in a manner which will protect construction throughout the various stages of work up to the point of final acceptance by Owner (City). The Contractor shall install and maintain all required or necessary erosion control measures to cover the entire duration of the term of the Contract.

The Contractor is responsible to protect the Project site from erosion damage at all times by utilizing interim erosion control measures which, due to the site's ever changing condition during construction, is achieved by implementing Best Management Practices (BMPs). The Contractor shall ensure that Best Management Practices (BMPs) are implemented.

### **1.31.2 Storm Water Pollution Prevention Plan**

The Contractor shall provide a site-specific Storm Water Pollution Prevention Plan (SWPPP) to the City prior to commencing construction. The Contractor shall ensure that the SWPPP for all sites are developed and amended or revised by a Qualified SWPPP Developer (QSD). The SWPPP shall conform to the requirements in the Permit, and these Special Provisions.

The objectives of the SWPPP shall be to identify pollution sources that may adversely affect the quality of storm water discharges associated with the project and to identify, construct, implement, and maintain water pollution control measures, hereafter referred to as control measures, to reduce to the maximum extent practicable (MEP, as defined in Title 33 CFR of the United States Code) pollutants in storm water discharges from the construction site both during and after construction is completed under this contract.

The SWPPP shall incorporate control measures in the following categories:

- 1) All pollutants and their sources, including sources of sediment associated with construction, construction site erosion and all other activities associated with construction activity is controlled.
- 2) Where not otherwise required to be under a Regional Water Board permit, all non-storm water discharges are identified and either eliminated, controlled, or treated.
- 3) Site Best Management Practices (BMPs) are effective and result in the reduction or elimination of pollutants in storm water discharges and authorized non-storm water discharges from construction activity to the Best Available Technology Economically Achievable/Best Conventional Pollutant Control Technology standard BAT/BCT standard).
- 4) Calculations and design details as well as BMP controls for site run-on are complete and correct.
- 5) Stabilization BMPs installed to reduce or eliminate pollutants before, during and after construction commencement.
- 6) Sediment tracking control practices
- 7) Wind erosion control practices and,
- 8) Non-storm water management and waste management and disposal control practices.

Specific objectives and minimum requirements for each category of control measures are contained in the Handbook. To demonstrate compliance with requirements of this General Permit, the QSD shall include information in the SWPPP that supports the conclusions, selections, use, and maintenance of BMPs.

The SWPPP shall include, but not be limited to, the following Bid Items as described in the Handbook and Permit:

- 1) Proper handling, storage, and disposal of materials.
- 2) Scheduling of excavation and grading to avoid open excavations or unprotected grading operations during wet weather.
- 3) Diversion of surface runoff water around work sites.
- 4) Means of preventing wind-blown dust or water borne erosion from escaping stockpiles and excavated soil.
- 5) Implementation of erosion control plans.
- 6) Inspection and repair of leaking equipment away from the construction site.
- 7) Location of equipment refueling sites and means of preventing fuel spillage and/or discharge of spilled fuel to storm drains or waterways.
- 8) Means of insuring that debris, sediment, and pollutants will be prevented from entering catch basins, storm drains, or waterways.

The QSD, shall amend the SWPPP, graphically and in narrative form, whenever there is a change in construction activities or operations which may affect the discharge of significant quantities of pollutants to surface waters, ground waters, municipal storm drain systems (MS4), or when deemed necessary by the City. The SWPPP shall also be amended if it is in violation of any condition of the Permit or has not effectively achieved the objective of reducing pollutants in storm water discharges. Amendments shall show additional control measures or revised operations, including those in areas not shown in the initially submitted SWPPP, which are required on the project to control water pollution effectively. Amendments to the SWPPP shall be submitted to the City and implemented by the Contractor.

The Contractor shall keep a copy of the SWPPP and all amendments at the project site, The SWPPP shall be made available upon request of a representative of the Regional Water Quality Control Board, State Water Resources Control Board, U.S. Environmental Protection Agency, or City of Upland storm water management team. Requests by the public shall be directed to the City.

When the original SWPPP is retained by a contractor's employee in a company vehicle and is not currently at the construction site, current copies of the BMPs and map/ drawings documents will be left with the onsite field crew. The original SWPPP shall be made available the same day, via a request by cellular phone, radio, or other means of rapid communication.

#### Notes:

The Permit requires Qualified SWPPP Developers (QSD) and Qualified SWPPP Practitioners (QSP) to obtain appropriate training, and makes this curriculum mandatory Before September 2, 2011, to allow time for course completion.

To ensure that the preparation, implementation, and oversight of the SWPPP is sufficient for effective pollution prevention, the Qualified SWPPP Developer (QSD) and Qualified

SWPPP Practitioners (QSP) responsible for creating, revising, overseeing, and implementing the SWPPP must attend a State Water Board sponsored or approved Qualified SWPPP Developer and Qualified SWPPP Practitioner training course.

Fact Sheet

Table 9 - Qualified SWPPP Developer/ Qualified SWPPP Practitioner Certification Criteria

Certification/ Title	Registered By	QSD/QSP	Certification Criteria
Professional Civil Engineer	California	Both	1. Approval Process 2. Code of Ethics 3. Accountability 4. Pre-requisites
Professional Geologist or Engineering Geologist	California	Both	1. Approval Process 2. Code of Ethics 3. Accountability 4. Pre-requisites
Landscape Architect	California	Both	1. Approval Process 2. Code of Ethics 3. Accountability 4. Pre-requisites
Professional Hydrologist	American Institute of Hydrology	Both	1. Approval Process 2. Code of Ethics 3. Accountability 4. Pre-requisites
Certified Professional in Erosion and Sediment Control™ (CPESC)	Enviro Cert International Inc.	Both	1. Approval Process 2. Code of Ethics 3. Accountability 4. Pre-requisites 5. Continuing Education
Certified Inspector of Sediment and Erosion Control™ (CISEC)	Certified Inspector of Sediment and Erosion Control, Inc.	QSP	1. Approval Process 2. Code of Ethics 3. Accountability 4. Pre-requisites 5. Continuing Education
Certified Erosion, Sediment and Storm Water Inspector™ (CESSWI)	Enviro Cert International Inc.	QSP	1. Approval Process 2. Code of Ethics 3. Accountability 4. Pre-requisites 5. Continuing Education
Certified Professional in Storm Water Quality™ (CPSWQ)	Enviro Cert International Inc.	Both	1. Approval Process 2. Code of Ethics 3. Accountability 4. Pre-requisites 5. Continuing Education

Payment for fulfilling the requirements of this Section and all Subsections shall be considered included in the contract LUMP SUM (LS) price bid for the Bid Item “Storm Water Pollution Prevention Plan and Implementation” and no additional compensation will be allowed therefore.

### 1.31.3 Rain Event Action Plan

1. The discharger shall ensure a QSP (after July 1, 2010) develop a Rain Event Action Plan (REAP) 48 hours prior to any likely precipitation event. A likely

precipitation event is any weather pattern that is forecast to have a 50% or greater probability of producing precipitation (POP) in the project area. The discharger shall ensure a QSP obtain a printed copy of precipitation forecast information from the National Weather Service Forecast Office (e.g., by entering the zip code of the project's location at <http://www.srh.noaa.gov/forecast>).

2. The discharger shall ensure a QSP develop the REAPs for all phases of construction (i.e., Grading and Land Development, Streets and Utilities, Vertical Construction, Final Landscaping and Site Stabilization).
3. The discharger shall ensure a QSP ensure that the REAP include, at a minimum, the following site information:
  - a. Site Address
  - b. Site Storm Water Manager Information including the name, company, and 24-hour emergency telephone number
  - c. Erosion and Sediment Control Provider information including the name, company, and 24-hour emergency telephone number
  - d. Storm Water Sampling Agent information including the name, company, and 24-hour emergency telephone number
4. The discharger shall ensure a QSP include in the REAP, at a minimum, the following project phase information:
  - a. Activities associated with each construction phase
  - b. Trades active on the construction site during each construction phase
  - c. Trade contractor information
  - d. Suggested actions for each project phase
5. The discharger shall ensure a QSP begin implementation and make the REAP available onsite no later than 24 hours prior to the likely precipitation event.
6. The discharger shall ensure a QSP maintain onsite a paper copy of each REAP onsite in compliance with the record retention requirements of the Special Provisions in the General Permit.
7. All "Pre, During and Post Rain Event" inspections shall be submitted via fax to 909-291-2974 within 48 hours from the end of rain event. (Alternately, check with project manger if email submittal is also acceptable for this project)

### **1.32 Parkway Restoration**

The Contractor shall restore parkway areas as well as private properties that were disturbed due to the Contractor's operation. Parkway restoration shall be done in accordance with and shall include all work specified in Subsection 300-1, "Clearing and Grubbing," and Subsection 7-9, "Protection and Restoration of Existing Improvements," of the SSPWC, except as modified below or specifically covered elsewhere in these Specifications.

The Contractor shall give reasonable written notice to occupants or owners of adjacent property to permit them to salvage or relocate plants, and other improvements within the right-of-way which are designated for removal and would be destroyed because of the work.

The Contractor shall be responsible for sod and root removal, backfill, compaction, grading of the parkway, and re-seeding in kind of parkway and grass areas where turf was removed or damaged by construction. The Contractor shall repair sprinkler systems damaged by construction at his own expense.

Areas in the parkway which have been raised (or humped) by tree roots, or tree removal, shall be corrected as described below and as directed by the Engineer. The parkway shall be graded to standard parkway cross slope between back of curb and property line adjacent to the whole length of the new improvement. Grading shall extend onto private property at a 4:1 slope where grading is required.

It may be necessary for the Contractor to import soil for backfilling parkway areas adjacent to concrete repairs. All parkway backfill shall be clean topsoil of the same composition and characteristics as the existing native topsoil, as approved by the Engineer. Clay, sand, rocks, rubble, or other deleterious materials will not be permitted in the backfill.

Unless a separate Bid Item is provided, payment for fulfilling the requirements of this Section shall be considered as included in the various Bid Items of work, and shall include furnishing all labor, materials, equipment, and incidentals necessary to perform the Bid Items of work. No additional compensation will be allowed therefor.

**SECTION 2      DEFINITION OF BID ITEMS**

The unit prices and lump sum amounts to be paid for the Items listed in the Proposal shall include full compensation for furnishing all labor, materials, tools, equipment, time, and incidentals necessary to complete the work, and for performing all work contemplated and embraced under the Contract, in accordance with the Plans and Specifications. This shall include the Contractor's costs involved with bonding, insurance, worker's compensation, overhead, financing, obtaining required permits and permit fees, mobilization, traffic control, public convenience and safety, protective barricading, sanitary facilities, storage of equipment and materials, security against theft and vandalism, project site maintenance, dust and runoff control, clean-up and all other items incidental to the work.

Payment for Unit Price work shall be made for the actual quantities of Contract Items removed, constructed, or disposed of in accordance with the Plans and these Specifications. Measurement of Unit Price work shall be as specified in Section 7-1, "Measurement of Quantities for Unit Price Work," of the SSPWC. Payment for Lump Sum work shall be paid for at the price indicated in the Bid, in accordance with Section 7-2, "Lump Sum Work," of the Standard Specifications for Public Works Construction (SSPWC).

**BASIC BID:**

Each respective bid item and bid schedule as shown on the proposal form shall comply with all respective Sections of the 2018 Edition of the Standard Specifications for Public Works Construction (Green Book), its supplements, and any other publications as specified, except as modified herein. If there is a conflict between these inclusions and the Standard Specifications, these inclusions shall have precedence.

**PART A – GENERAL ITEMS (ITEMS 1-5)**

**1.      Traffic/Pedestrian Control, Public Convenience and Safety.**

This Bid Item shall include all work, materials, and equipment necessary to comply with the requirements of Subsection 7-10, "Safety," of the SSPWC, the Caltrans' Manual of Traffic Controls in Construction and Maintenance Zones (latest edition), the standards contained in the "Work Area Traffic Control Handbook" (WATCH) published by Building News, Inc.; (latest edition); Section 1-9, "Temporary Traffic Control," of the General Requirements of these Special Provisions, and the City-approved Traffic Control Plan provided by the Contractor, except as modified and supplemented herein. In the case of a conflict, the highest standard shall prevail.

The Contractor shall maintain two-way vehicular traffic at all times.

Ten working days prior to the start of construction work, the Contractor is required to submit to the City a traffic control plan prepared and signed by a licensed (licensed by the State of California) Traffic or Civil Engineer.

To allow for equipment movement and cleanup during various construction operations, momentary stoppage of traffic and turn movements will be permitted, using flagging procedures. During work at the intersections, the Contractor shall maintain a minimum of one 12-foot westbound and eastbound lane.

If at any time during the course of construction the City Engineer, or his representative, deems traffic control measure are inadequate, or construction impacts to traffic are too great, the Engineer may require changes be made to the traffic control. All costs as a result of traffic control modifications/ changes shall be borne solely by the Contractor.

Payment for "Traffic/Pedestrian Control, Public Convenience & Safety" shall be made at the Contract Lump Sum Price, and shall include full compensation for furnishing all labor, materials tools, equipment, and incidentals, and for doing all the work involved in furnishing and installing the signs as specified herein.

Progress payments shall be pro-rated in proportion to the total value of work completed to date as a function of the total awarded contract amount.

## **2. Construction Surveying**

This Bid Item includes, but is not limited to, surveying and construction staking in order to provide vertical and horizontal control necessary for this project. The Contractor shall hire a licensed land surveyor to inspect the project limits and identify all survey monuments found. The project shall be inspected following the City's Notice to Proceed and prior to beginning construction. The Contractor's surveyor shall submit to the City a letter stating that a reasonable and diligent field search was conducted and list the monuments found. The letter shall be submitted to the City prior to construction.

Contractor shall perform construction staking for underground construction and street improvements, as required on this project. Construction stakes or marks shall be set and maintained as necessary to achieve the required accuracy set forth on the Plans and Specifications. Stakes (blue tops) for subgrade and base shall be at 50-foot intervals, maximum. The Contractor shall set and maintain sufficient stakes at each cross section to match plan cross-sections, achieve the required accuracy, and to support the method of field operations. Contractor shall set and maintain stakes as necessary to establish horizontal and vertical position along intersecting road radii, vertical and horizontal curves, and curve transitions.

**All Survey Cut Sheets shall be submitted to the Engineer prior to the start of excavation work.**

The Contractor shall assist the Engineer for final elevation checks, if necessary. Such checks shall be made at randomly selected points.

Any questionable grade, elevation, location, or design shall be brought to the immediate attention of the Engineer in writing for clarification prior to construction. Any additional survey required to correct such construction shall be at the sole expense of the Contractor, and no additional compensation will be made therefor.

The City reserves the right to verify all staking and monumentation for horizontal and vertical accuracy. Any staking, monuments, or reference points (centerline ties) found to exceed allowable error shall be reset at the sole expense of the Contractor, and no additional compensation will be made therefor. All work shall be done by or under the direction of a Professional Land Surveyor or a Registered Civil Engineer licensed to practice land surveying. Copies of all grades sheets and corner records shall be provided to the Engineer.

Prior to the commencement of construction, contractor shall obtain centerline tie notes available at the City of Upland Public Works Department to determine which monuments are in harms way. All monuments that are within 3.0 feet of the proposed construction shall be perpetuated by the witness monuments shown on the City of Upland Monument notes, or by a minimum of four (4) centerline tie points set in existing curbs or other durable features in the near vicinity of the Monument that is being perpetuated, with a measured distance from each tie point to the centerline monument. Tie point monuments shall be of the character approved by the City of Upland. After construction, replace all monuments disturbed or destroyed by construction in kind. Set Class "C" well monuments per detail available at the City of Upland; all other monuments shall be of a character approved by the City of Upland. Measure new tie distances to the replaced centerline monument and submit centerline tie notes and corner records prepared by the Contractor's surveyor, to the Engineer and to the County Surveyor's office for approval. The Contractor shall determine all monuments that need to be replaced prior to construction.

Full compensation for conforming to the requirements of this Bid Item, including furnishing all labor, tools, equipment, documentation, and materials for doing the work and resetting monuments shall be included in the contract LUMP SUM price bid, and no additional compensation will be allowed.

### **3. Storm Water Pollution Prevention Plan**

As part of this project, the Contractor shall provide a site-specific Storm Water Pollution Prevention Plan (SWPPP) to the City prior to commencing construction. The Contractor shall ensure that the SWPPP for all work is developed and amended or revised by a Qualified SWPPP Developer (QSD). The SWPPP shall conform to the requirements in the Permits, and these Special Provisions.

The objectives of the SWPPP shall be to identify pollution sources that may adversely affect the quality of storm water discharges associated with the project and to identify, construct, implement, and maintain water pollution control measures, hereafter referred to as control measures, to reduce to the maximum extent practicable (MEP, as defined in Title 33 CFR of the United States Code) pollutants in storm water discharges from the construction site both during and after construction is completed under this contract.

**Contractor shall have designated concrete wash as required per NPDES requirements prior to begin any concrete work.**

This Bid Item shall include all work involved in compliance with the requirements of Section 1.31, "NPDES Requirements," of these Special Provisions.

Payment for this Bid Item shall be at the contract LUMP SUM price bid for Storm Water Pollution Prevention Plan & Implementation and shall be considered as full compensation for preparing and implementing the SWPPP, furnishing all labor, materials, tools, equipment, time, and incidentals for doing all work involved in construction of this Bid Item, and no additional compensation will be allowed therefor. Payment shall be based on progress of the work completed at the City's discretion.

**4. Pothole and Utility Verification. Supply Potholing Data to City Engineer**

This Bid Item shall include the verification, by the Contractor, of the locations of existing utility mains and lateral lines including storm drain, sanitary sewer, water, gas, underground electrical and communication conduits and any other underground conduits and utilities crossing the trench excavation. As provided in Section 4216 of the California Government Code, at least two (2) working days prior to commencing any excavation, the Contractor shall contact the regional notification center (Underground Service Alert of Southern California) and obtain an inquiry identification number. Contractor shall expose all crossing utilities ahead of any boring or trench operations.

Potholing is done by digging test hole to expose underground utilities to ascertain the horizontal and vertical location of such facility. The horizontal and vertical position of the exposed facility must be tied to a survey benchmark or permanent above grade feature.

The locations of existing underground utilities shown on the Plan has been determined only from record. The Contractor shall excavate the utilities, shown on the plan or marked in the field, to be within the construction area and verify their exact locations prior to excavating for improvements. This excavation shall be coordinated with the City. Any variation from the positions shown on the Plan with the position determined by verification shall be immediately reported to the City. If necessary, modifications on the vertical and/or horizontal alignment of the proposed underground utilities shall be made based upon the pothole data obtained.

Potholing shall include, but not limited to the following:

- a. Excavating and exposing utility line connection points and any potential interfering utilities. The Contractor shall use the method of excavation which offers the least risk of hitting and damaging the very utility they were trying to locate and protect.
- b. Identifying the type, size, other characteristics, and the position of the facility (i.e., station, distance from center or curb lines, depth) and providing these data to the City.
- c. Backfill and surface restoration. After the underground utility has been located and required data have been collected and submitted to the City, at the direction of the Engineer, pothole should be restored immediately or as required by the Engineer. Appropriate sediment controls should be utilized during all potholing activities to prevent storm water pollution. The pothole should be clean and dry prior to backfilling. Backfilling of the excavation and the restoration of pavement or surfacing shall be in accordance with the SSPWC. Requirements for the backfill materials to be used for the potholes shall be crushed aggregate from the bottom to subgrade level and asphalt concrete for the top surface.

Where underground main distribution conduits such as water, gas, sewer, electric power, telephone, or cable television are shown on the Plans, the Contractor, for the purpose of preparing a Bid, shall assume that every property parcel will be served by a service connection for each type of utility.

The Contractor's attention is directed to Section 5, "Utilities," Subsection 5-1, "Location" of the SSPWC, and Section 1-1.3.2, "Utility Location and Protection," of these Special Provisions.

**Contractor shall submit potholing data on a set of plans showing depths of all utilities to the City Engineer at least 7 working days prior to beginning underground utility installation.**

Payment for this Bid Item shall be made at the contract LUMP SUM price bid for Potholing and Utility Verification, and shall include all labor, materials, tools, equipment, time, and incidentals necessary to complete this work, and no additional compensation will be allowed therefor.

**5. Clearing and Grubbing**

Clearing and Grubbing shall conform to Section 300-1 of the Standard Specifications and additionally shall consist of pruning of tree roots; and improvements as necessary to construct the rehabilitation improvements as shown on plans and as directed by Engineer. Removal shall be done in accordance with Section 300 1.3 of the Standard Specifications and these Special Provisions.

Payment for Clearing and Grubbing shall be made at the contract LUMP SUM (LS) price, shall be paid based on the percentage of completed work to date, and shall include all labor, materials, tools, equipment, time, and incidentals necessary to complete this work, and no additional compensation will be allowed therefor.as specified.

**Part B – Street Improvements (Item 6-11)**

**6. Unclassified Excavation and Subgrade Preparation**

This Bid Item includes the removal and disposal of the existing asphalt concrete pavement, and if necessary, the adjoining base and/or subgrade materials on alley and other locations, as shown on the Plan and as specified herein, in accordance with Section 300-2, "Unclassified Excavation," of the SSPWC, except as modified and supplemented herein. This shall also include the preparation of subgrade, (grading, compaction, etc.) in accordance with Subsection 301-1, "Subgrade Preparation," of the SSPWC.

Compaction testing shall be done by the City or its representative at no cost to the Contractor. However, compaction retests shall be paid for by the Contractor. The Contractor shall notify the City Inspector 48 hours in advance of compaction testing.

In order to minimize interference with traffic and to facilitate removal of materials and restoration of the roadway, excavation shall be done by cold milling. The cold milling operation shall be completed in accordance with Subsection 302-1, "Cold Milling of Existing Pavement," of the SSPWC, except as modified or supplemented herein. **The cold-milled areas shall be based-paved with AC on the same day the pavement is removed**, except when determined by the Engineer that such schedule is impractical due to field conditions.

The depth of removal by cold milling varies, as shown on the Plan. Where it is determined by the Engineer that the resulting surface will not be suitable for AC paving, the depth of cut will be adjusted as directed by the Engineer in the field, as the work progresses.

Also, conditions may be encountered that require additional excavation in order to bridge unsuitable base materials. The Engineer may order the removal of additional existing base materials at selected locations during the removal process. The Contractor shall implement

whatever measures are practical during removal operations to maintain the existing subgrade integrity. Any subgrade disturbed or removed due to the Contractor not using the extra care outlined or for his convenience, shall be graded and compacted to the required elevations at no additional cost to the City.

The Contractor shall be responsible for obtaining a suitable disposal site for this excavated material, and pursuant to Subsection 300-2.6, "Surplus Material," of the SSPWC, shall, upon request, file with the Engineer the written consent of the owner of the property upon which he intends to dispose of such material.

The Contractor shall verify locations of existing manhole and utility valve box covers prior to start of cold milling work.

- a. The cold milling machines shall be operated so as not to produce dust, fumes, or smoke. For smaller or tight areas at curb returns, smaller grinders may be used to facilitate the operation.
- b. Residue from grinding shall not be permitted to flow or travel into gutters, onto adjacent street surfaces or parkways. All residues shall be completely removed by sweeping or by vacuuming and properly disposed. No washing of residue into drainage structures or devices will be allowed.
- c. The pavement surface shall be swept by means of a sweeper having the capabilities to effectively sweep and retain dust, dirt, and debris from the pavement. The suction fan shall move air from the main brush compartment through the air filter in sufficient volume during sweeping to prevent escape of visible dust from the brush compartment directly into the air.
- d. The Contractor shall provide all general survey control and any required specialized control for the type of machine that is being used per the requirements of Bid Item No. 3, "Construction Surveying", of these Special provisions and per the SSPWC.
- e. The Contractor shall thoroughly inspect the work site in advance of the cold milling operation to determine and mark locations of utility covers (sewer and storm drain manholes, water valves, etc.), which, if struck, could damage the machine's cutting drum and/or carbide teeth.
- f. The Contractor shall scan the existing pavement surface in advance of the cold milling machine using an electronic metal detector/locator device to ascertain the location of buried valve boxes, manhole covers and other substructures, which could potentially damage the cold milling machine.

All costs, including downtime, incurred by the Contractor due to the breakdown of the cold milling machine shall be at the Contractor's expense.

This bid item shall also include saw cut along the edge of proposed removals.

Payment for this Item, even though bid on a cubic-yard basis, will be made for the fixed quantity estimated by the Engineer, as shown on the Bid Proposal, and shall include grading, subgrade preparation and compaction. These quantities are calculated based upon the depth of removal shown on the Plan. No allowance has been made for bulking during excavation. The final pay quantity will be adjusted by change order, to reflect any excavation change authorized by the Engineer.

**7. Construct 8" Thick PCC Alley Gutter**

This Bid Item shall include the construction of 3-foot PCC alley "V" gutter at the locations shown on the Plan, in accordance with Section 303-5, "Concrete Curbs, Walks, etc.," of the SSPWC and Detail "A" Sheet 1 of the Plan. Concrete to be used shall be Class 520-C-2500.

All concrete flowlines shall be water-tested upon completion of finishing, and any irregularities causing water ponding shall be corrected and refinished.

Payment for "Construct PCC Alley 'V' Gutter," shall be made at the Contract Unit Price per square foot of gutter constructed and shall include all work described herein and shown on the Plan, including labor, materials and equipment necessary to complete this work. No additional compensation will be allowed therefor.

Payment for the excavation and subgrade preparation shall be included under Bid Item 6, "Unclassified Excavation and Subgrade Preparation," of these Special Provisions.

**8. Remove Existing and Construct PCC Alley Intersection**

This Bid Item shall include the removal and reconstruction of PCC alley intersection, as shown on the Plan, and/or as marked in the field together with excavation, root removal protection and/or replacement of all existing drains, subgrade preparation, backfill, compaction and cleanup. All work shall be completed in accordance with SPPWC Standard Plan No. 130-2, and applicable provisions of Subsections 300-2, "Unclassified Excavation," 301-1, "Subgrade Preparation," and 303-5, "Concrete Curb, Walk...", of the SSPWC. All PCC improvements to be removed shall be sawcut at join lines prior to removal.

In order to maintain access to the residents, the alley shall be constructed one half at a time, or at the option of the Contractor and upon approval by the Engineer, a "high early" strength concrete may be used, so that 4 hours after its pour, the new driveway, with steel plates covering, shall be capable to withstand the imposed load without damage.

Should an alley approach be excavated at the end of a workday, the Contractor shall provide a temporary access ramps or steel plates for vehicles to be able to pass through.

This bid item shall also include slot paving along the edge of gutter.

Payment for this Bid Item shall be made at the Contract Unit Price per Square Foot of alley intersection constructed and shall include be full compensation for all labor, materials, tools, equipment, time, and incidentals necessary to complete this work, and no additional compensation will be allowed therefor.

**9. Remove and Reconstruct 4" Thick PCC Sidewalk**

This Bid Item shall include the sawcut, removal, and disposal of existing improvements and construction of 4-inch-thick Portland Cement Concrete (PCC), as shown on the Plan, and/or as marked in the field. This shall also include excavation, root removal, subgrade preparation,

backfill, compaction, cleanup, and replacement of existing drains, if any, removed or damaged by the new construction. New sidewalk scoring shall be installed with a scoring tool and shall match existing scoring pattern adjacent to the new sidewalk improvements.

Four-inch-thick PCC to be removed and reconstructed shall include, but not limited, to the following:

- a. Sidewalk
- b. Walkways
- c. Walkway transitions
- d. Slabs adjacent to curb

All work shall be completed in accordance with SPPWC Standard Plans 112-2 and 113-2, and Subsections 300-2, "Unclassified Excavation," 301-1, "Subgrade Preparation," 300-1.3, "Removal and Disposal of Materials," and 303-5, "Concrete Curbs, Walks, etc.," of the SSPWC. All PCC improvements to be removed shall be sawcut at join lines prior to removal. The Contractor shall remove A.C. ramping from existing PCC to be left in place and joined. Damage to the improvements to be left in place shall be remedied by sawcutting, removal and reconstruction at the Contractor's expense and to the satisfaction of the Engineer. Under sidewalk drain shall be in accordance with SPPWC Standard Plan 150-3. Restoration of the parkway shall be done in accordance with Section 1.32, "Parkway Restoration," of the General Requirements of these Special provisions.

Wherever a tree well exists or is proposed in the new sidewalk, forming for the tree well shall be included in the contract unit price for this Bid Item. No additional compensation will be provided for installing and removing forms for tree wells.

Payment for "Remove and Reconstruct 4-Inch Thick PCC Sidewalk, Walkway & Slab" shall be made at the Contract Unit Price bid per Square Foot of PCC constructed, and shall include full compensation for all labor, materials, tools, and equipment involved, and all work described herein, and no additional compensation will be allowed

**10. Construct 2.5" Thick Asphalt Base Course Type B PG64-10.**

This Bid Item shall include construction of a 2.5-inch-thick Dense Graded Asphalt Concrete (DGAC) base course, as shown on the Plan, in accordance with Subsections 203-6, "Asphalt Concrete," and 302-5, "Asphalt Concrete Pavement," of the SSPWC, except as modified or supplemented herein.

**DGAC for the base course shall consist of Type B PG-64-10 with 5.2 percent asphalt binder (3/4" sieve size). A maximum of 10% Reclaimed Asphalt Pavement (RAP) may be used on this project.**

The AC base course shall be thoroughly compacted by rolling. The number of rollers necessary will be established in accordance with Table 302-5.6.1 of the SSPWC. The compacted DGAC shall have a relative compaction of not less than 95 percent in accordance with Subsection 302-5.6.2, "Density and Smoothness," of the SSPWC.

Tack coat shall be Grade SS-1h emulsified asphalt per subsection 302-5.4 of the Standard Specifications. Tack coat shall be applied at an approximate rate of 0.05 to 0.10 gallon per square yard uniformly in one coat on all cold milled surfaces, vertical joints on AC and PCC surfaces and edges against which AC is to be placed.

Curbs, walks, gutters, and other existing improvements shall be protected to prevent spattering, splashing, or tracking with tack coat. Any spots of tack coat materials left over these existing improvements shall be thoroughly removed by the Contractor at his expense.

The contact surfaces of all cold pavement joints, curbs, gutters, cold milled area etc. shall be painted with Grade SS-1h emulsified asphalt immediately before the adjoining AC pavement is placed. The Contractor shall clean the existing pavement surface, including gutters, immediately prior to application of the tack coat. Cleaning shall be accomplished by means of a self-propelled, mechanical street sweeper. The Contractor shall also be responsible for sweeping areas inaccessible to mechanized sweeping equipment. All debris generated shall be removed from the project site and properly disposed of. Use of air blowing equipment shall be prohibited.

The Contractor shall use a paving machine for the placement of the asphalt concrete base course. The asphalt paving machine shall be equipped with a hydraulically extendable variable width screed with heating and vibration for uniform compaction and surface texture over the entire width of the paving mat. The standard screed width shall be ten feet (10'), capable of extension to at least 12 feet.

The initial breakdown rolling, and the finished rolling shall be accomplished with a two-axle tandem roller, minimum 8 to 10 tons.

The Contractor shall water-test all finished A.C. surfacing prior to final inspection. Any irregularities causing water to stand shall be corrected at the Contractor's expense.

Temporary surfacing shall be placed only when directed by the Engineer, to safeguard the public. Payment for temporary surfacing shall be included in the unit price bid for Asphalt Concrete Base Course, unless otherwise specified in these Specifications.

Payment for this Bid Item will be made at the Contract Unit Price per ton (TON) of Dense Graded Asphalt Concrete (DGAC) Base Course Type B PG 64-10 constructed, based upon certified weighmaster's tickets. The unit price bid for the DGAC Base Course shall include all work described herein, materials, labor, tools, time, equipment, and incidentals required to complete the work. No additional compensation will be allowed therefor.

#### **11. Construct 1.5-inch Thick Asphalt Overlay Type C2 PG 64-10**

This Bid Item shall include construction of a 1.5-inch-thick Dense Graded Asphalt Concrete (DGAC) Overlay, as shown on the Plan, in accordance with Subsections 203-6, "Asphalt Concrete," and 302-5, "Asphalt Concrete Pavement," of the SSPWC, except as modified or supplemented herein.

**DGAC for the Overlay shall consist of Type C2 PG-64-10 with 5.2 percent asphalt binder (1/2" sieve size). A maximum of 10% Reclaimed Asphalt Pavement (RAP) may be used on this project.**

All other requirements of bid item 10 shall apply.

Full compensation for all the preceding requirements, including corrective work, shall be included in the Contract Unit Price bid per ton (TON) for Construct 1.5-inch Thick Asphalt Overlay Type C2 PG 64-10 constructed, based upon certified weighmaster's tickets. The unit price shall include adjusting water valve covers/cans to finish surface, compaction, labor,

tools, time, equipment, materials, and incidentals required to complete the work. No additional compensation will be allowed therefor.

## **Part C – Flashing Beacon Improvements**

### **12. Furnish and Install PVC Electrical Conduits per Final SCE Plans**

This item shall include furnishing and installing PVC Electrical conduits as shown on the Southern California Edison Final Design Plans.

New conduit shall be minimum 3" SCH 80 PVC in accordance with Section 700-3.5 in the Standard Specifications for Public Works Construction as well as in accordance with the Southern California Edison Final Design Plans.

**The Contractor shall properly dispose of all trench excavation materials encountered and shall import sand and Crushed Aggregate Base (CAB) or Crushed Miscellaneous Base (CMB) for pipe bedding and trench backfill.** CMB shall conform to Subsection 200-2.4, "Crushed Miscellaneous Base," and Table 200-2.4.2 (fine, 3/4" max. size) of the SSPWC. CAB shall conform with Subsection 200-2.2, "Crushed Aggregate Base," and Table 200-2.2.2 (3/4" max. size) of the SSPWC. Sand shall be in accordance with Subsection 200-1.5, "Sand," of the SSPWC.

Payment for this item of work shall be at the unit price bid per LINEAL FOOT (LF) and shall be considered as full compensation for all labor, tools, equipment, materials, time, trenching, backfill and incidentals required for doing all work involved in construction of this item, and no additional compensation will be allowed therefore.

### **13. Furnish and Install Electrical Pull Box:**

This item shall include furnishing and installing pull box and sweeps as shown on the Southern California Edison Final Design Plans.

Payment for this item of work shall be at the contract unit price bid per EACH (EA) and shall be considered as full compensation for all labor, tools, equipment, materials, time and incidentals required for doing all work involved in construction of this item, including adjusting pull boxes to final grade, and no additional compensation will be allowed therefore.

### **14. Furnish and Install Electrical Service with Foundation:**

This item shall include furnishing and installing electrical service connection and cabinet equipment including, but not limited to foundation and circuit breakers for Flashing Beacon Service as shown on the Southern California Edison Final Plans and in accordance with Standard Specifications for Public Works Construction Section 700-3.10 and 700-3.11.

Payment for this item of work shall be at the contract unit price bid per EACH (EA) electrical service constructed in place, and shall be considered as full compensation for all labor, tools,

equipment, materials, time and incidentals for doing all work involved in construction of this item, and no additional compensation will be allowed therefore.

**15. Install City Provided Flashing Beacon Equipment**

This item shall include furnishing and installing flashing beacon equipment. All work shall be in accordance with Standard Specifications for Public Works Construction Section 700.

All equipment shall be Carmanah R829-G Cabinet-Based School Zone Flashing Beacon equipment as shown in Appendix "H".

Location 1: 1100<sup>th</sup> West Eleventh Street.

Location2: Fronting 893 West 11<sup>th</sup> Street.

Payment for this item of work shall be at the contract unit price bid per EACH (EA) of the two flashing Beacon Locations, complete in place, and shall be considered as full compensation for all labor, tools, equipment, transportation, hauling/deliveries, materials, time and incidentals necessary to complete the work as shown on the plans and in these Special Provisions, including coordination with the City of Upland and Southern California Edison Company. No additional compensation will be allowed therefore.

**END OF SPECIAL PROVISIONS**



## **APPENDIX "A"**

# **REQUIRED PERMITS AND CITY OF UPLAND BUSINESS LICENSE FOR**

---

**PROJECT Nos. 7031, 85003, & 86004  
BID No. 2024-05  
ELEVENTH STREET FLASHING SIGNAL  
BEACON& ALLEY IMPROVEMENTS**

---

### Construction Notes:

- ① Remove and Replace alley intersection per SPPWC Standard 130-3.
- ② Construct 8" Alley PCC Gutter Per Detail "A".
- ③ Coldplane Existing AC, 2-inch depth.
- ④ Construct 2.5-Inch Thick AC Base Course Type B PG 64-10.
- ⑤ Construct 1.5-Inch Thick AC Type C PG 64-10.
- ⑥ Remove and Replace 4" PCC Sidewalk per SPPWC 113-2.
- ⑦ Install 3" Schedule 80 PVC Conduit.

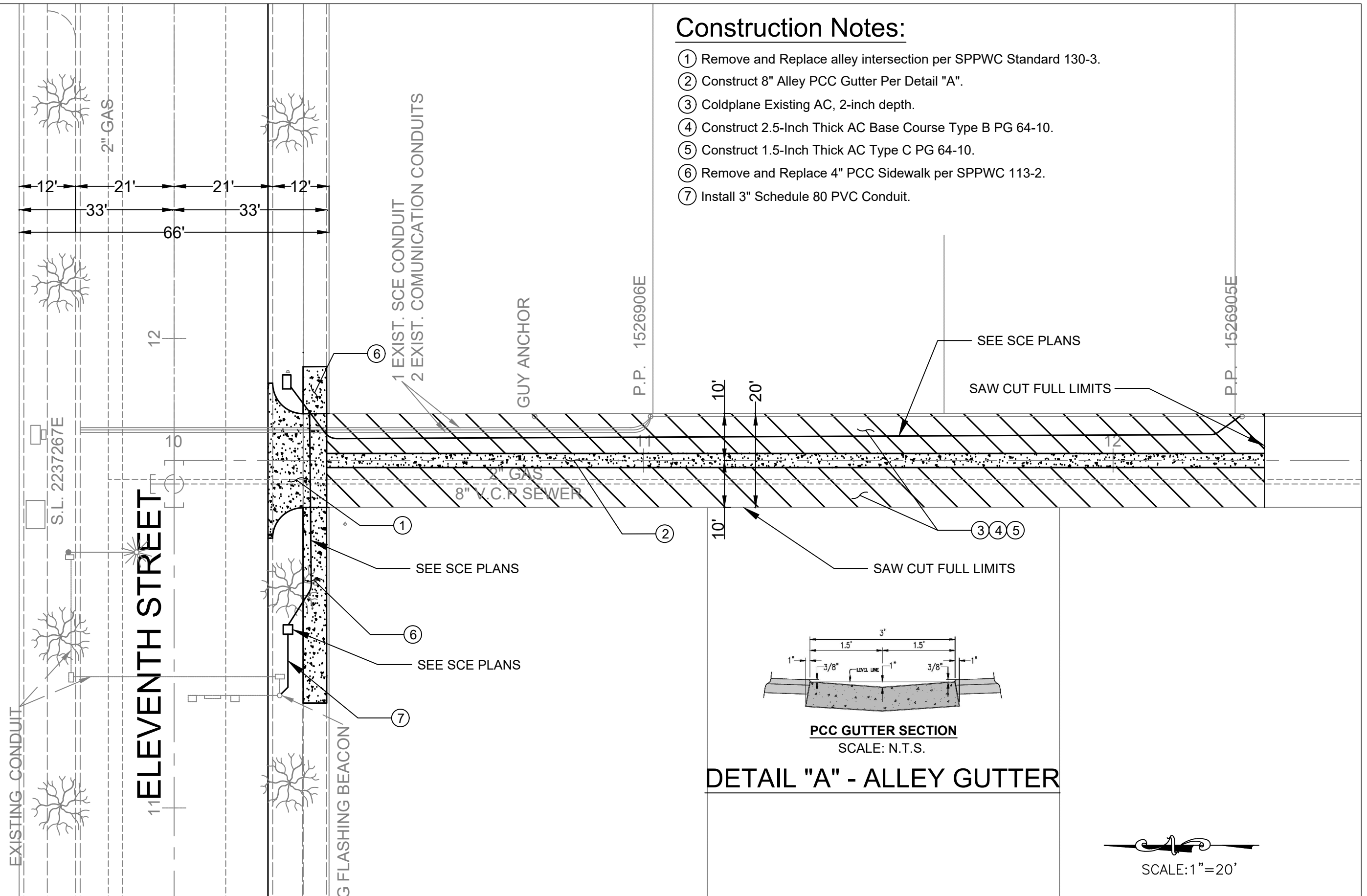

**11TH STREET FLASHING SIGNAL BEACON IMPROVEMENTS**  
**PROJECT NO. 85003**



## **APPENDIX "B"**

# **REQUIRED PERMITS AND CITY OF UPLAND BUSINESS LICENSE FOR**

---

**PROJECT Nos. 7031, 85003, & 86004  
BID No. 2024-05  
11TH STREET FLASHING SIGNAL BEACON &  
ALLEY IMPROVEMENTS**

---



Finance Stamp Here

Construction Permit No. \_\_\_\_\_

Inspector: \_\_\_\_\_

Final Inspection By: \_\_\_\_\_

Street/Lane Closure Permit No. \_\_\_\_\_

NOTE TO PERMITTEES: ANY WORK NOT LISTED ON THE CITY'S ACTIVE CONSTRUCTION MONITORING LIST, WILL BE SHUT DOWN IMMEDIATELY. PERMIT HOURS 7:00 AM TO 3:30 PM (M-F)

This Permit is not valid without the following items completed.

- Pre-Construction Meeting is MANDATORY before work begins; please contact Inspection at (909) 291-2963 to schedule your meeting. WORK SHALL NOT COMMENCE UNTIL THE PRE-CON MEETING HAS TAKEN PLACE, OR PERMIT WILL BE REVOKED AND PROJECT WILL BE SHUT DOWN IMMEDIATELY. PRE-CONSTRUCTION MEETINGS MAY BE SCHEDULED AFTER A MINIMUM OF THREE WORKING DAYS FROM THE PERMIT ISSUANCE DATE.
A Temporary Street Closure Permit is required. No Street shall be closed, vehicular traffic, or pedestrian access impeded in any way without said permit, please allow 4 to 8 City business days for permit processing. Please contact the Permit Engineer at PWPERMITS@CI.UPLAND.CA.US for permit information.
A Truck Access Plan is required before the work begins; please contact the Permit Engineer at PWPERMITS@CI.UPLAND.CA.US for necessary information to complete the Access Plan.
At Risk Improvements applies to Contractors requesting to work in the Public Right-Of-Way without approved plans. The Developer/Contractor is proceeding at their own risk in commencing this work without City Approved Plans. The Developer/Contractor has supplied the appropriate bonding and Indemnity Letter.
Underground Service Alert at 1-800-227-2600 shall be notified by applicant at least 2 working days in advance of any excavation and an Underground Service Alert Inquiry Identification Number shall be obtained from Underground Service Alert. CONTACTING U.S.A. DOES NOT RELIEVE CONTRACTOR OF RESPONSIBILITY FOR LOCATING OR PROTECTING EXISTING UTILITIES.

Reference (Tract, P.M., S.P., C.U.P., or Address): \_\_\_\_\_

General Location/City Plan#/Project #: \_\_\_\_\_

Contact Name: \_\_\_\_\_ E-mail Address: \_\_\_\_\_

Contractor: \_\_\_\_\_ Telephone: \_\_\_\_\_

License Number: \_\_\_\_\_ Expiration Date: \_\_\_\_\_

Address: \_\_\_\_\_

Developer (Owner): \_\_\_\_\_ Telephone: \_\_\_\_\_

Address: \_\_\_\_\_

Applicant's Statement

The undersigned hereby applies for permission to undertake, or to have undertaken, construction work within public right-of-way in the City of Upland. Said undersigned has read the conditions provided as Supplemental Permit Information. Said undersigned hereby agrees to observe and comply with all permit provisions. All applicable Sections of the Upland Municipal Code and all applicable Sections of the City of Upland Standard Specification for Public Works Construction, and to complete said construction work all in accordance with the approved plan, and/or standard drawing and/or engineering directives and/or special conditions.

Applicant's Printed Name Signature Date Signed

This Permit Expires on: \_\_\_\_\_ Extension \_\_\_\_\_ Approved By \_\_\_\_\_

Permit Approval: \_\_\_\_\_ City Engineer or Authorized Representative Date

**Items to be constructed or activities with this Permit**

**Street**

- AC Paving
- Curb & Gutter
- Drive Approach
- Sidewalk
- Miscellaneous Items
- Per Attached Plans

**Sewer**

- Sewer Main
- Manhole
- Sewer Lateral

Paid with Receipt Number

\_\_\_\_\_

**Water**

- Water Main
  - Water Lateral
  - Fire Hydrant
- Storm drain**
- Storm drain Main

**Miscellaneous**

- Pavement Repairs
- Parkway Landscaping
- Utility Trench
- Splice Pit
- Aerial Work
- Traffic Control Inspection
- Grading
- Stockpile/Material Placement
- Square Feet Soil Disturbed

\_\_\_\_\_

**Fees**

**Account Number**

Permit Fee: \_\_\_\_\_

101-300-0000-3205

Inspection Deposit: \_\_\_\_\_

101-300-0000-3645

Total Due this Permit: \_\_\_\_\_

**REFUND REMAINING DEPOSIT TO:** \_\_\_\_\_

**Permit Work Hours**

Permit work hours are from **7:00 AM to 3:30 PM**, Monday through Friday (excluding holidays). Any work after 3:30 PM is subject to the overtime inspection rate. Any work outside of the permit hours must be submitted in writing a minimum of four (4) business days/permit hours in advance.

**NO WORK ON WEEKENDS AND HOLIDAYS ALLOWED BY THIS PERMIT PERMIT IS VALID ONLY WITHIN CITY RIGHT OF WAY; WORKS ON PRIVATE PROPERTY NEED PRIVATE OWNER'S PERMISSION. ALL PERTINENT ORDINANCES APPLY. PRE-CONSTRUCTION MEETING IS MANDATORY. PAVING WORKS MUST BE COMPLETED WITHIN 30 DAYS FROM BACKFILL IF INCLUDED IN THE SCOPE OF WORKS AND MUST USE ORDINANCE 841.**

**Temporary Street Closure**

Temporary Street Closures require a separate permit and a minimum of 3 to 7 permit business days for processing. Prior to the start of any temporary street and/or lane closure, the applicant is required to notify and receive City approval a minimum of 72 permit business hours in advance. Permit business hours are Monday through Thursday from 8:00 AM to 4:00 PM.

**Permit Fee Structure**

The minimum fee for a Construction Permit is \$325.00 and is non-refundable. This minimum fee is for minor construction usually for a utility tie-in for a single-family home. Projects that are more extensive require a review on a case-by-case basis.

**Public Works Inspection Deposit (Defined)**

Inspections are based on an hourly rate. Staff performs an audit when the Inspector finalizes a Construction Permit. This audit consists of deducting the Inspector's documented time (shown on their time sheet) from the deposit.

**Permit Extensions**

Each permit extension will be assessed a new processing fee. The minimum fee is \$130.00 for each extension. Extension fees will automatically be assessed until the Permittee provides written notification to the City that the construction and all associated activities have been completed and that the permit has been finalized/signed-off by the Public Works Inspector.



# City of Upland Public Works Land Development and Transportation Division

## PERMIT APPLICATION TEMPORARY STREET AND LANE CLOSURES

**NOTE: Please allow a minimum of 8 working days to process the permit application. For Inspections Call (909) 291-2963.**

Start Date: \_\_\_\_\_ Completion Date: \_\_\_\_\_

Location: \_\_\_\_\_

Description of Street / Lane Closure: \_\_\_\_\_

Contact Name: \_\_\_\_\_ Project Number: \_\_\_\_\_

Company Name: \_\_\_\_\_ E-mail Address: \_\_\_\_\_

Address: \_\_\_\_\_ Daytime Phone: \_\_\_\_\_

City, State, Zip: \_\_\_\_\_ Emergency Phone: \_\_\_\_\_

**Traffic Control Plans (check all that apply):**

- Latest edition of WATCH manual plan/sketch
- Latest edition of CJUTCM manual plan/sketch
- Engineered Traffic Control Plans (TCP)

<b>Fees</b>	_____ Full Closure \$450.00 (Subject to Approval)
	_____ Partial Closure \$450.00
	_____ Block Party \$40.00
	_____ Vzn/TW/SCE/Gas - WO# _____
	_____ Traffic Control Plan Check (per fee schedule)

**ALL APPLICATIONS MUST CONTAIN THE FOLLOWING INFORMATION. FAILURE TO PROVIDE THE INFORMATION WILL RENDER THE APPLICATION INCOMPLETE AND WILL NOT BE PROCESSED BY CITY STAFF.**

1. Proof of valid California contractor's license
2. Proof of valid City Business license
3. Certificate of Liability Insurance (min. \$1M, with City named as additionally insured)
4. Proof of Workers Compensation
5. Any applicable fees
6. Site plan
7. City Project Number (if applicable)

**I agree to all terms, conditions and restrictions listed on the back of the application.**

Print Name \_\_\_\_\_ Signature \_\_\_\_\_ Date \_\_\_\_\_

**FOR CITY STAFF USE ONLY:**

Permit _____	<input type="checkbox"/> 8:30 am to 3:30 pm
	<input type="checkbox"/> 8:30 am to 2:00 pm (School Zone)
Effective Date(s): _____ to _____	Work Hours: <input type="checkbox"/> _____ to _____
Permit Number _____	Closure Type: <u>Full / Partial</u> (circle one)
Permit issued by City of Upland _____	_____
	Signature _____ Date _____
Receipt Number _____	Amount Paid \$ _____ CIP or Project # _____
Extended Date(s): _____ to _____	By: _____ Date Extended: _____
Permittee to contact City: _____	Contacted By: _____ Date of Call: _____
<input type="checkbox"/> (72 hours prior to date)	<b>Distribution</b>
<input type="checkbox"/> Permittee	<input type="checkbox"/> Fire
<input type="checkbox"/> PW Traffic	<input type="checkbox"/> PW Inspector
<input type="checkbox"/> PW Operations Manager	

**Traffic Control Plans:**

Work Area Traffic Control Handbook (WATCH) or California Joint Utility Traffic Control Manual (CJUTCM) – It is the responsibility of the applicant to present the City with a reasonable assessment of how the required work zone and existing field condition fits this category. The existing field condition/lane geometry must match the proposed drawing being referenced in the source document.

Engineered Traffic Control Plans (sign and stamped by a registered Traffic Engineer) – For major projects or projects affecting major arterials and/or intersections involving temporary traffic control beyond the scope of WATCH or CJUTCM, an engineered traffic control plan will be required. Final determination of this requirement is made by traffic engineering staff. Engineered plans shall be stamped and signed by a registered civil traffic engineer. Allow two weeks for review of the first plan check submittal and one week for review of subsequent submittals of engineered traffic control plans.

**General Notes**

The Contractor shall provide and install barricades, delineators, warning devices, and construction signs in accordance with the latest edition of California Manual on Uniform Traffic Control Devices (M.U.T.C.D.). During adverse weather or unusual traffic or working conditions, additional traffic devices shall be placed as directed by the Public Works Director or Authorized Representative.

The Contractor shall relocate, preserve, and maintain the visibility of all existing signs within the project limits, which affect the flow of traffic, as directed by the Public Works Director or Authorized Representative. The Contractor at his expense as directed by the Public Works Director or Authorized Representative shall replace any signs, which are damaged or found to be missing during the course of construction.

The City of Upland and its elected officials, officers, agents, and employees shall not be answerable or accountable in any manner of any loss or damage that may happen to the work or any part thereof, or for any of the materials or other things used or employed in performing the work, or for injury or damage to any person or persons, either workmen, employees or Contractor or his Sub-Contractors or the public, or for damage to adjoining or other property from any cause whatsoever arising out of or in connection with the performance of the work. The Contractor shall be responsible for any damage or injury to any person or property resulting from defects or obstructions or from any cause whatsoever, except the sole negligence or willful misconduct of City, its employees, servants, or independent Contractors who are directly responsible to City during the progress of the work or at any time before its completion and final acceptance.

The Contractor will indemnify City and its elected officials, officers, agents, and employees against and will hold and save harmless from any and all actions, claims, damages to persons or property, penalties, obligations, or liabilities that may be asserted or claimed by any person, firm, entity, corporation, political subdivision, or other organizations arising out of or in connection with the work, operation, or activities of the Contractor, his agents, employees, Sub-Contractors, or invitees provided for herein whether or not there is concurrent passive or active negligence on the part of the City, its elected officials, officers, agents, and employees, but excluding such actions, claims, damages to persons or property, penalties, obligations, or liabilities arising from the sole negligence or willful misconduct of the City, its employees, servants, or independent Contractors who are directly responsible to City, and in connection therewith: The Contractor will defend any action or actions filed in connection with any of said claims, damages, penalties, obligations or liabilities and will pay all costs and expenses, including attorney's fees incurred in connection therewith.

**Conditions**

- Prior to the start of the temporary street closure, the applicant is required to notify and receive City approval a minimum of 72 permit business hours in advance (909) 931-4137. Permit business hours are M-Th from 8:00 AM to 4:00 PM.
- Please contact Inspection at (909) 291-2963 for Pre-Con.
- All signs shall be graffiti free and monitored/replaced when damaged.
- Must use flashing arrow boards for lane closures on all streets except for local/residential streets.
- Must backfill or steel plate all trenches during non-working hours.
- Post-temporary "NO PARKING" signs in the vicinity of the work area a minimum of 48 hours prior to closure. Signs shall clearly state effective dates and time of parking restriction.
- Must maintain one (1) lane of traffic in each direction at all times (Min. 12' wide lane).
- Protect any traffic signal detection equipment in-place or restore any equipment damaged by the Permittee within five (5) working days.
- Must maintain access for emergency vehicles to all driveways.
- Must notify all affected residents by letter or door hanger of the street closure a minimum of 48 hours in advance.
- When work is within a school zone, all sidewalks and traffic lanes shall remain open during non-working hours.
- Discretion per City Engineer or Inspector to change Traffic Control.

**Restrictions/Comments:** \_\_\_\_\_

# Building Permits

## Permit Issuance and Plan Submittal

The City of Upland's Building and Safety Division offers three ways to obtain a Building Permit:

- 1.) Permit Issuance using the [Citizen Self Service Portal \(CSS\)](#) - requires an electronic device (e.g. computer or cell phone).
- 2.) Permit Issuance using the [Citizen Self Service Portal \(CSS\)](#) located at City Hall with assistance provided by a Building and Safety Division Permit Technician.
- 3.) Plan Submittal, Review and Approval at City Hall by APPOINTMENT ONLY with a Building and Safety Permit Technician and/or Plans Examiner.

## Permit Issuance using Citizen Self Service Portal (CSS)

Upland's new Citizen Self Service Portal (CSS) is an online permitting system that allows its citizens and contractors doing business within the City to obtain a permit for many construction activities using their electronic device (computer or cell phone).

To use the CSS Portal, please click the link below and enter the REQUIRED information prompted by the online application. Please note that many questions may not apply to your specific project, but still require you to enter the number zero (0) in these fields to process your online permit. These areas are designated as 'REQUIRED' and processing your application will not be completed unless all required fields have the quantity you are requesting or the number zero (0).

**THE CSS PORTAL MAY BE FOUND HERE: [CSS Portal](#)**

Payment for the construction permit is by Credit Card only.

It is important to note that a many permits issued using the CSS Portal require the applicant to upload construction plans that will accompany the permit. Please see the list of available online permits below that are identified as requiring construction plans during the online application process.



For answers to your questions regarding the use of the CSS Portal, please contact Building and Safety at (909) 931-4110 option 1.

## HOW TO Guidelines - CSS Portal

All new users of the CSS Portal must register for an account. In order to apply for a permit or schedule an inspection, an account is required. Once logged in, all permits associated with the applicant's account will be available for viewing online. Guest users can only view permit history for a specific address within the City's boundary limits.

[Create and account online - CSS](#)

[Create a Permit - CSS](#)

**NOTE TO CONTRACTORS: ALL STATE OF CALIFORNIA LICENSED GENERAL OR SPECIFIC TRADE CONTRACTORS PERFORMING WORK IN CITY OF UPLAND ARE REQUIRED TO HAVE A CURRENT BUSINESS LICENSE. IF YOU DO NOT HAVE A CURRENT BUSINESS LICENSE, OR YOU NEED TO APPLY FOR A BUSINESS LICENSE, PLEASE CONTACT UPLAND'S BUSINESS SUPPORT CENTER AT (909) 348-0460 OR ONLINE AT [HTTP://UPLAND.HDLGOV.COM](http://upland.hdlgov.com). ALSO, YOU ARE REQUIRED TO UPLOAD A COPY OF YOUR CONTRACTOR'S LICENSE AND BUSINESS LICENSE DURING THE APPLICATION PROCESS. A PDF OR JPEG (PHOTO) FILE IS ACCEPTABLE.**

**Beginning January 3, 2022, the following permit applications must be submitted electronically using the City's Citizen Self Service Portal (CSS Portal). The permit applications that are limited to online submittal include:**

Residential Kitchen Remodel\*

Residential Bathroom Remodel\*

Residential Swimming Pools and Spas\*

Residential Patio Covers, Balconies, Decks\*

Residential Rooftop Solar PV Systems\*\*\*

Accessory Dwelling Units (ADU)\*

Junior Accessory Dwelling Units (Jr ADU)\*

Residential Garage Conversion\*\*

Residential and Commercial Reroof

Residential and Commercial Electrical Main Service Panel Upgrade

Residential and Commercial Plumbing Repairs

Residential and Commercial Mechanical Repairs and Change-outs

Residential Retaining and Garden Walls\*

Commercial Signs\*

\*Requires submittal of Construction Plans showing the proposed improvements.

\*\* Requires submittal of Construction Plans showing the proposed improvements. Also, an onsite Consultation with a Building Inspector is required prior to performing ANY construction on the job site.

\*\*\*Electrical Plans, Manufacturer's Product Information and Listings, Roof Plan and other pertinent information is required for the installation of the PV System and Electrical Equipment.

## Projects that do not require a building permit

Click on the PDF for more information on projects that do not require a building permit. If you have additional questions contact the Building Department at (909) 931-4110

[California Building Code  
section 105](#)

# Required Building Permit Submittals



[Residential Construction  
Application](#)

[Commercial/Industrial  
Application](#)

## California Contractors State Licensing Board

For information on how to select a licensed, qualified contractor; check the status of a contractor license; negotiate a clear contract; prevent disputes and mechanics liens; and resolve contractor disputes download the pamphlet or go to the [California Contractors State License State Board website](#).

[What You Should Know  
Before Hiring a Contractor](#)

CITY  
OF UPLAND  
CALIFORNIA

460 N. Euclid Avenue  
Upland, CA 91786  
(909) 931-4100

**Hours of Operation:**  
Monday - Thursday  
8:00 a.m. to 6:00 p.m.



## **Business License Fee Schedule**

Effective January 18, 1988, a \$15.00 one-time application fee is added to all new Business License fees. This includes previous City of Upland business license holders who have closed their businesses and wish to re-open. Unless otherwise stated, all license fees (exclusive of application fee) are not to exceed \$864.00 per year.

Retail, Wholesale, Contractor, Service, or any business not otherwise specified will be based on gross receipts as follows:

0	to	20,000	=	\$ 54.00	<b><i>This category limited to Upland Based Businesses Only</i></b>
0	to	40,000	=	\$ 75.60	
40,001	to	60,000	=	97.20	
60,001	to	100,000	=	140.40	
100,001	to	200,000	=	183.60	
200,001	to	300,000	=	216.00	
300,001	to	400,000	=	279.00	
400,001	to	500,000	=	324.00	
500,001	to	600,000	=	378.00	
					600,001
					to
					700,000
					=
					432.00
					700,001
					to
					800,000
					=
					486.00
					800,001
					to
					900,000
					=
					540.00
					900,001
					to
					1,000,000
					=
					594.00
					1,000,001
					to
					1,100,000
					=
					648.00
					1,100,001
					to
					1,200,000
					=
					702.00
					1,200,001
					to
					1,300,000
					=
					756.00
					1,300,001
					to
					1,400,000
					=
					810.00
					1,400,001
					to
					1,500,000
					=
					864.00

### **ADDITIONAL CATEGORIES**

Administrative Offices

Base fee .....	54.00 per year
Each employee .....	4.50 per year

Manufacturing

One to five employees.....	54.00 per year
Six to fifteen employees .....	108.00 per year
Sixteen to thirty employees .....	216.00 per year
Over thirty employees .....	324.00 per year

Professional / Semi-Professional

Each practicing member of the firm (including real estate agents) .....	54.00 each per year
Each non professional/semi professional employee .....	4.50 each per year

Recreation & Entertainment

Rides or games of skill .....	54.00 per year
Arcade games .....	54.00 per year
Social club, Dancing club .....	108.00 per year

Residential Property Rentals

Three units or rooms .....	54.00 per year
Each additional unit or room .....	4.50 per year

Solicitations

Solicitors, canvassers, peddlers.....	216.00 per year / per person
---------------------------------------	------------------------------

Transportation

Delivery by Vehicle.....	54.00 per year / per vehicle
Taxicabs .....	54.00 per year / per vehicle

Other

Circus, carnival, etc .....	(issued by permission of City Manager) 540.00 per year
Public Utilities .....	216.00 per year



**CITY OF UPLAND**

Business Support Center  
Business Licensing Division  
8839 N Cedar Ave #212  
Fresno, CA 93720

(909) 348-0460 , 8:00 a.m. – 5:00 p.m., M-F  
support@hdlgov.com

**Business License Number**

**Business License Application**

This application is for:

- CITY OF UPLAND BUSINESS
- CITY OF UPLAND HOME OCCUPATION BUSINESS LICENSE
- CONTRACTOR OR OUTSIDE SERVICE DOING BUSINESS IN UPLAND
- CHANGE OF BUSINESS NAME\*
- CHANGE OF BUSINESS ADDRESS\*

\*Prior Business Name: \_\_\_\_\_ \*Prior Business Address: \_\_\_\_\_

**GENERAL BUSINESS INFORMATION**

Business Name (DBA): \_\_\_\_\_ Start Date: \_\_\_\_\_

Business Location: \_\_\_\_\_ City: \_\_\_\_\_ State: \_\_\_\_\_ Zip: \_\_\_\_\_

Mailing Address: \_\_\_\_\_ City: \_\_\_\_\_ State: \_\_\_\_\_ Zip: \_\_\_\_\_

Business Telephone: ( ) - \_\_\_\_\_ No. of Employees: \_\_\_\_\_ Gross Receipts (Projected Next 12 Months): \_\_\_\_\_

Business Description (detailed summary): \_\_\_\_\_

**OWNERSHIP TYPE/ IDENTIFICATION NUMBERS/OTHER INFORMATION**

**OWNERSHIP TYPE:**  Corporation Corporation Name: \_\_\_\_\_

Sole Proprietorship  Husband & Wife Sole Proprietorship  Partnership  Non-Profit Org. (Exempt)  LLC

Federal Employer ID: \_\_\_\_\_ State Employer ID: \_\_\_\_\_ State Sales Tax/Resale #: \_\_\_\_\_

Contractor License #: \_\_\_\_\_ Class: \_\_\_\_\_ Social Security: \_\_\_\_\_ - - SIC Code: \_\_\_\_\_

**OWNER/PARTNER/OFFICER INFORMATION**

(1)	(2)	(3)
Name: _____	Name: _____	Name: _____
Title: _____	Title: _____	Title: _____
Home Address: _____	Home Address: _____	Home Address: _____
City/State/Zip: _____	City/State/Zip: _____	City/State/Zip: _____
Email Address: _____	Email Address: _____	Email Address: _____
Home Telephone: _____	Home Telephone: _____	Home Telephone: _____
Cell Telephone: _____	Cell Telephone: _____	Cell Telephone: _____
Drivers License #: _____	Drivers License #: _____	Drivers License #: _____
Social Security #: _____ - -	Social Security #: _____ - -	Social Security #: _____ - -

**NOTICE:** I declare under penalty of perjury that the information I have provided is true and correct. I certify I will operate my business in accordance with all applicable Federal, State, and City laws and regulations. I understand that any false statements made are in violation of the City of Upland Municipal Code and are grounds for revocation of the Certificate of Business License. I understand that the term of the Certificate issued for this application will expire if I cease to meet the issuance qualifications. I authorize the City of Upland and its agents to seek information and/or conduct an investigation on this application.

\_\_\_\_\_  
Authorized Signature

\_\_\_\_\_  
Print Signature Name

\_\_\_\_\_  
Date

Please check to sign up for our Economic Development mailing list E-mail: \_\_\_\_\_



# CITY OF UPLAND

BUSINESS LICENSE & ZONING CLEARANCE  
APPLICATION PACKAGE

# Starting a Business in the City of Upland?

## Great!

*The City of Upland would like to welcome you to its business community. We know that starting a new business can be exciting and challenging. We wish you success in your new venture!*

*To operate any business within the City of Upland you must first obtain a business license and meet all zoning requirements. For your convenience we have included a business license application, zoning clearance form, and a list of some of the additional requirements that you may need to consider when applying for your business license.*

*The City of Upland has contracted with The HdL Companies to provide assistance to the business community for all of their business licensing needs. The Business Support Center offers extended telephone support hours via their toll free telephone number as well as email contact options.*

*You may contact the Business Support Center for your entire business license needs anytime Monday through Friday from 8am to 5pm at:*

- Toll-Free by Phone: 888-602-0239
- E-mail: [businesstax@hdlcompanies.com](mailto:businesstax@hdlcompanies.com)
- Apply online: <https://upland.hdlcompanies.com/>
- Apply by mail: 8839 N. Cedar Avenue #212  
Fresno, CA 93720

# A GUIDE FOR STARTING A NEW BUSINESS IN UPLAND

The City of Upland is excited that you have chosen to operate a business in our community and we value the many businesses that have made Upland their home. This guide is intended to assist you through our business approval process. The process includes three steps:



Outside contractors who perform work in Upland at the request of individual property owners and who do *not* have a physical location in Upland do not need zoning approval and may skip Step 2 (Zoning Clearance).

The process mentioned above is outlined in more detail below including a description of the specific steps and the agency to contact. Some businesses also have special circumstances. Please read the details below for more information:

Step	What to Do	Who to Contact
<b>Step 1</b>	<b>Obtain Business License Tax Certificate</b>	
<b>1.1</b>	<b>Name The Business</b>  This is a very important part of beginning your business since it is the item that will identify you, your service and/or your product to the consumer. Once you have decided your business name, ascertain if the name is available for use. Make inquiries to confirm availability with the Secretary of State for corporate names and San Bernardino County Recorder's office for fictitious name filings.	<b>City of Upland</b> Business Support Center 888-602-0239  ➔ You can also apply online at: <a href="https://upland.hdlcompanies.com/">https://upland.hdlcompanies.com/</a>
<b>1.2</b>	<b>File And Publish A Fictitious Name Statement</b>  If the business is not a legal entity registered with the State of California, or it does not contain the owners surname, such as Jones Roofing, a Fictitious Name Statement must be filed with the County Recorder's office in the county in which the business is based (San Bernardino). This is also a requirement for partnerships not recognized by the State.	<b>San Bernardino County</b> Recorder's Office 855-732-2575

Step	What to Do	Who to Contact
------	------------	----------------

**1.3 Determine The Legal Status Of Your Business**

Most businesses are classified under one of the following categories of legal status:

**Legal or Financial Advisor**

- Sole-Proprietor – A business owned by a single person or husband and wife who receives profits.
- Partnership – Two or more persons who are co-owners of a business for profit.
- Corporation – An independent legal tax entity, which remains intact even if its officers and/or directors change; must provide *Articles of Incorporation or DBA (Doing Business As), if applicable.*
- Limited Liability Corporation (LLC) – A non-corporate business whose owner actively participates in the organization’s management and are protected against personal **liability**.
- Non-Profit – Must be recognized by the IRS as an exempt entity; *must provide supporting documentation – (Section 501C(3)).*
- Other

Check with your legal or financial advisor for the status best suited for your business. Questions concerning incorporation of a business should be directed to the Secretary of State, an attorney, financial advisor, or trade association.

**1.4 Apply For Tax ID Numbers**

If you plan to hire employees for your business, you must obtain tax identification numbers for reporting purposes. These numbers are used to identify your business on payroll and business income tax returns. To apply for a Federal number, contact the IRS, for a state number contact EDD.

**State of California**  
Employment Development (EDD)  
800-300-5616

**US Department of Treasury**  
Internal Revenue Service  
800-829-1040

**1.5 Workers Comp Insurance**

Workers Compensation Insurance is required by the State of California for any business with employees. Contact the State Industrial Relations Department for information and requirements. Some insurance agencies may also be able to assist.

**State of California**  
Industrial Relations Department  
800-963-9424

**1.6 Obtain Required Permits**

Depending upon the type of business, certain permits may be required. Below is a list of possible permits that may apply to your business.

Sellers Permit: All retail and wholesale businesses must obtain a Sellers Permit or Resale Permit from the State Board of Equalization. This may be applied for at any local office. Every business that sells goods must collect and then remit sales tax to the State of California. This process is set in motion with the application for the sellers permit.

**State of California**  
State Board of Equalization  
951-680-6400  
800-400-7115

Health Permit: Eating establishments - food sales and handling. Any business dealing with consumable products must obtain a permit from the County Environmental Health Services Department.

**San Bernardino County**  
Environmental Health Services  
800-782-4264

Hazardous Materials: Any business which handles hazardous materials (i.e. automotive repair) is also required to obtain a permit from the County Environmental Health Services Department. All businesses should contact the County to verify whether or not a permit is required.

**San Bernardino County**  
Environmental Health Services  
800-782-4264

Child/Day Care: Although daycare businesses operated from a private residence are exempt from City business licensing if there are six or fewer children, a State license is required regardless of the number of children. The County and Development Services Department should also be contacted for any additional requirements.

**State of California**  
Community Care Licensing  
951-782-4200  
800-300-5616

Alcohol Sales: Businesses selling alcohol products consumed on or off the premises must obtain a permit from the California Department of Alcoholic Beverage Control (ABC). The City's Development Services Department should also be contacted for any additional requirements.

**State of California**  
Department of Alcoholic  
Beverage Control (ABC)  
(951) 782-4400

Secondhand Dealers and Pawn Shops: Businesses are required by the Department of Justice (DOJ) to possess and display a Secondhand Dealer or Pawn Broker license. The Upland Police Department serves as a liaison between the DOJ and the business owner. Contact the Upland Police Department Detective Bureau and request an application for license and Live Scan Service. Also, the Upland Planning Division can tell you whether the proposed business location is zoned for secondhand dealers and pawn shops.

**City of Upland**  
Planning Division  
909-931-4130  
  
Upland Police Department  
\*909-946-7624  
  
*\*Non-Emergency Number*

Massage Industry: Businesses are required to obtain and display certification from the California Massage Therapy Council. Contact the California Massage Therapy Council for information on certification. Please note certifications for all employees must be obtained prior to issuance of a zoning clearance from the Upland Planning Division.

**City of Upland**  
Planning Division  
909-931-4130  
  
**State of California**  
Massage Therapy Council  
916-669-5336

## 1.7 Complete and Submit the Business License Application

Submit your **Business License Application** to the Business Support Center. Be sure to include a copy of your signed zoning clearance application. After filing with all required agencies, a business is ready to obtain a business license. Submit the zoning clearance, all State and County licenses and permits, your fictitious name filing, corporate or partnership documentation and your Tax ID numbers to the Business Support Center. You may also file online at: <https://upland.hdlcompanies.com/>

**City of Upland**  
Business Support Center  
1142 S. Diamond Bar Blvd #502  
Diamond Bar, CA 91765  
888-602-0239

No payment will be required until your application has been reviewed and accepted. You will receive an email verifying the receipt of application. After the business tax fees are paid a business license number issued. A hard copy certificate will be mailed in approximately 6-8 weeks. Upon receipt, the Upland Municipal Code requires it be posted in a conspicuous place within the business.

➔ *Please continue to the zoning clearance section (STEP 2) if your business will be located or based inside the City of Upland.*

Step	What to Do	Who to Contact
<b>Step 2</b>	<b>Obtain Zoning Approval For Your Location</b>	
	<p><b>2.1 Local Zoning And Building Codes</b></p> <p>Visit the Planning Division section of the City’s website and review the zoning forms in this package to find out more about the zoning, land use, and building code requirements for your proposed business location. Be sure to do this before you sign leases or sales agreements, and before making any interior or exterior alterations.</p> <p>The Business Support Center staff will assist you determine what zoning clearance, home occupation permit, or other type of prerequisite your business will required based on the activity and location of your proposed business. If your business only requires a zoning clearance or home occupation permit, you may go to Step 2.2</p>	<p><b>City of Upland</b>            Planning Division            909-931-4130</p>
	<p><b>2.2 Complete and Submit the Zoning Clearance Forms</b></p> <p>All new business must complete and submit a <b>Zoning Clearance Application</b>. Please submit all zoning related documentation to the Business Support Center with your Business License Application. If you plan to conduct your business from a residence (home based business) located in the City of Upland you will also need to complete a <b>Home Occupation Application</b>.</p> <p><i>** Please note that once a zoning clearance is approved, it is only active for 30 day period. It is very important that you complete all the required prerequisites for your business type in order to obtain a business license certificate. **</i></p>	<p><b>City of Upland</b>            Business Support Center            888-602-0239</p>
	<p><u><b>Building Permit:</b></u> Businesses wishing to make interior or exterior alterations to a tenant space must obtain any necessary permits from the Development Services Department.</p>	<p><b>City of Upland</b>            Planning Division            Development Services            909-931-4130</p>
<b>Step 3</b>	<p><b>Construction</b></p> <p>After obtaining building permits, perform any construction or building modifications required by the City as necessary for the successful operation of your business. Once you have passed a final inspection or received a certificate of use and occupancy, you may open for business.</p>	<p><b>City of Upland</b>            Building &amp; Safety Division            909-931-4110</p>
<b>Step 4</b>	<p><b>GRAND OPENING!</b></p> <p>Congratulations! We hope your business thrives in the City of Upland.</p>	

## ADDITIONAL INFORMATION

Additional sources for information pertaining to starting or relocating a business include: Chamber of Commerce, the Small Business Administration, counselors, attorneys, your local library, financial advisors, tax consultants, and the City of Upland website and Municipal Code.

## DISCLAIMER

This handout is intended as a guideline and tool for business owners. The City of Upland does not guarantee these are the only steps your particular business may need prior to opening. Any technical questions should be directed to the responsible agency or your professional consultant. Upland cannot take responsibility for operation of your business.

# HELPFUL NUMBERS

---

There are a number of entities involved in the process of obtaining all necessary licenses and permits when opening a business at the local, State, and federal level. The following is a list of helpful numbers of these various agencies:

## UPLAND CITY OFFICES

[www.ci.upland.ca.us](http://www.ci.upland.ca.us)

### CITY HALL

460 N. Euclid Avenue  
Upland, CA 91785  
(909) 931-4100

### BUILDING DIVISION

460 N. Euclid Avenue  
Upland, CA 91785  
(909) 931-4110

### BUSINESS LICENSES

Business Support Center  
8839 N. Cedar Avenue #212  
Fresno, CA 93720  
(888) 602-0239

### CODE ENFORCEMENT

460 N. Euclid Avenue  
Upland, CA 91785  
(909) 931-4260

### PLANNING DIVISION

460 N. Euclid Avenue  
Upland, CA 91785  
(909) 931-4130

### FIRE DEPARTMENT

475 N. 2nd Avenue  
Upland, CA 91785  
Non-Emergency (909) 931-4180

### PUBLIC WORKS

1370 N. Benson Avenue  
Upland, CA 91785  
(909) 931-4230

### POLICE DEPARTMENT

1499 W. 13th Street  
Upland, CA 91785  
Non-Emergency (909) 946-7624

## COUNTY OFFICES

<http://www.sbcounty.gov/>

### AUDITOR/CONTROLLER/RECORDER

Fictitious Business Name  
222 W. Hospitality Lane, First Floor  
San Bernardino, CA 92415-0022  
(855) REC-CLRK or (909) 387-8306

### DEPARTMENT OF PUBLIC HEALTH

County Government Center  
385 N. Arrowhead Avenue  
San Bernardino, CA 92415  
(800) 782-4264

## MISCELLANEOUS

### CHAMBER OF COMMERCE

215 N. 2nd Ave., #D  
Upland, CA 91785  
[www.uplandchamber.org](http://www.uplandchamber.org)  
(909) 204-4465

### CALIFORNIA MASSAGE THERAPY COUNCIL

One Capitol Mall, Suite 320  
Sacramento, CA 95814  
[www.camtc.org](http://www.camtc.org)  
(916) 669-5336

### BETTER BUSINESS BUREAU

[www.bbb.org](http://www.bbb.org)  
(909) 825-7280

### INLAND EMPIRE SMALL BUSINESS DEVELOPMENT CENTER

3780 Market Street  
Riverside CA 92501  
[www.iesmallbusiness.com](http://www.iesmallbusiness.com)  
(951) 781-2345

## STATE AND FEDERAL OFFICES

[www.ca.gov](http://www.ca.gov)

### ALCOHOLIC BEVERAGE CONTROL (ABC)

[www.abc.ca.gov](http://www.abc.ca.gov)

(951) 782-4400

### ATTORNEY GENERAL

[www.caag.state.ca.us](http://www.caag.state.ca.us)

(800) 952-5225

### BOARD OF EQUALIZATION

[www.boe.ca.gov](http://www.boe.ca.gov)

Riverside Office

(951) 680-6400 or (800) 400-7115

### CONSUMER AFFAIRS

[www.dca.ca.gov](http://www.dca.ca.gov)

(800) 952-5210

### CONTRACTOR'S STATE LICENSING BOARD

[www.cslb.ca.gov](http://www.cslb.ca.gov)

Sacramento

(800) 321-2752

### DEPARTMENT OF JUSTICE (DOJ)

[www.oag.ca.gov](http://www.oag.ca.gov)

Sacramento

(800) 952-5225

### DEPARTMENT OF SOCIAL SERVICES COMMUNITY CARE LICENSING

[www.cclld.ca.gov](http://www.cclld.ca.gov)

Riverside/San Bernardino Office

(951) 782-4200

### EMPLOYMENT DEVELOPMENT

[www.edd.ca.gov](http://www.edd.ca.gov)

(800) 300-5616

### FRANCHISE TAX BOARD

[www.ftb.ca.gov](http://www.ftb.ca.gov)

(800) 338-0505

### INTERNAL REVENUE SERVICE (IRS)

[www.irs.gov](http://www.irs.gov)

(800) 829-1040

### SECRETARY OF STATE

[www.sos.ca.gov](http://www.sos.ca.gov)

Sacramento

(916) 653-3795

### SMALL BUSINESS ADMINISTRATION

[www.sbaonline.sba.gov](http://www.sbaonline.sba.gov)

(800) U-ASK-SBA

# ADDITIONAL INFORMATION

---

## BUSINESS LICENSE REQUIREMENTS

Businesses operating within Upland City limits are required to have a business license. This includes home-based businesses, contractors, and outside services doing business in Upland. Chapter 5.04 of the Upland Municipal Code states in part, "It is unlawful for any person to transact and carry on any business, trade, profession, calling, or occupation in the city (Upland) without first having procured a license . . ."

## FILING YOUR BUSINESS LICENSE APPLICATION

The Business License Application is a general form used for all types of businesses; complete only applicable information pertinent to your business.

Contractors: Must include their State Contractors License Number.

Residential Property Rental: If there are less than 3 total rental units NO business license is required in the City of Upland.

Fictitious Name Statement: If surname is not included in the business name, a Fictitious Name Statement and proof of publication must be provided.

## BUSINESS DESCRIPTION

Provide a detailed description of the type of business you intend to operate. It may be necessary to attach a written operations summary to include a detailed analysis of what your business operations entail.

## RENEWAL

***The City will mail one courtesy renewal notice annually.*** It is your responsibility to renew your business license during the month following the expiration of your license. Penalties will be assessed if the City does not receive your renewal payment during this timeframe. Business licenses will expire either on June 30th or on December 31st of each year.

## CLOSURE

You must notify the Business Support Center in writing when you close your business.

## CHANGES

Notify the Business Support Center in writing if you have a change of address or a change of business name; fee is \$2.00. Licenses are non-transferable. If you sell your business, it is your responsibility to notify the City and close your license. The new business owner or entity must apply for a new license.

## SB-1186 FEE

State Law SB-1186 requires the City to charge a fee of \$1 on any application for a business license or similar instrument, permit, or renewal thereof. The purpose of this fee is to increase disability access and compliance with construction-related accessibility requirements, and to develop educational resources for businesses in order to facilitate compliance with federal and state disability laws, as specified. SB-1186 was signed into law by Governor Jerry Brown on September 19, 2012 and became effective on January 1, 2013.

*\*\*\* The above information provides general information on applying for a Business License in the City of Upland. Should you require additional information, please contact Customer Service at 888-602-0239 \*\*\**



## **APPENDIX "C"**

### **STANDARD DRAWING**

**FOR**

---

**PROJECT Nos. 7031, 85003, & 86004  
BID No. 2024-05  
11TH STREET FLASHING SIGNAL BEACON &  
ALLEY IMPROVEMENTS**

---

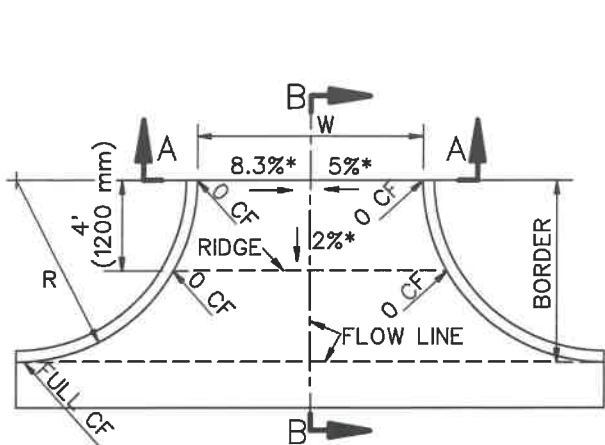

CASE A  
STANDARD APPROACH

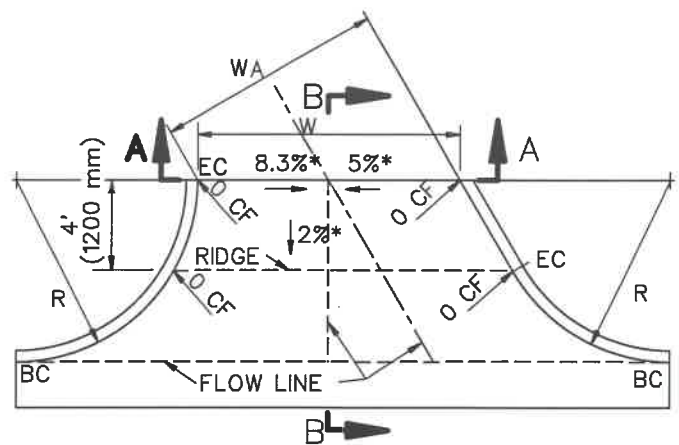

CASE B  
ANGLED APPROACH

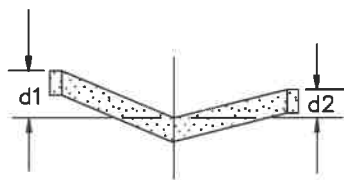

SECTION  
A-A

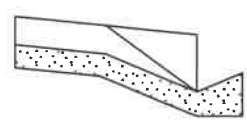

SECTION  
B-B

W, ft	8'	10'	15'	20'	25'	30'
W, mm	(2400 mm)	(3000 mm)	(4500 mm)	(6000 mm)	(7500 mm)	(9000 mm)
d1, ft	0.33'	0.42'	0.63'	0.83'	1.04'	1.25'
MAX	(100 mm)	(125 mm)	(188 mm)	(250 mm)	(313 mm)	(375 mm)
d2, ft	0.17'	0.25'	0.25'	0.25'	0.25'	0.25'
MIN	(50 mm)	(75 mm)	(75 mm)	(75 mm)	(75 mm)	(75 mm)

NOTES:

1. ALLEY INTERSECTION SHALL BE CONSTRUCTED OF CONCRETE, CLASS 520-C-2500 (310-C-17), 6" (150 mm) THICK.
2. ASTERISKS (\*) SHOW MAXIMUM GRADES.

STANDARD PLANS FOR PUBLIC WORKS CONSTRUCTION

PROMULGATED BY THE  
PUBLIC WORKS STANDARDS INC.  
GREENBOOK COMMITTEE  
1984  
REV. 1996, 2009, 2021

ALLEY INTERSECTION

STANDARD PLAN

130-3

USE WITH STANDARD SPECIFICATIONS FOR PUBLIC WORKS CONSTRUCTION

SHEET 1 OF 1

## WALK OR FILL-IN REPLACEMENT FOR EXCAVATIONS MADE PARALLEL TO CURB OR PROPERTY LINE

### WALK ADJACENT TO PROPERTY LINE

WALK LESS THAN 5' (1500 mm) WIDE

WALK 5' (1500 mm) WIDE OR MORE

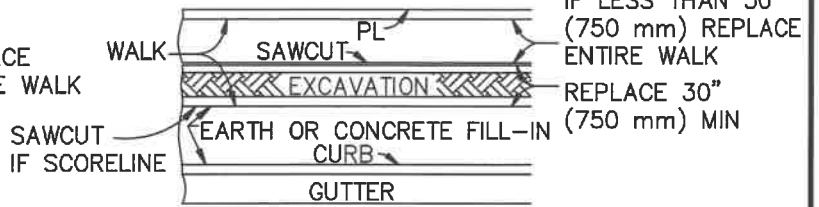
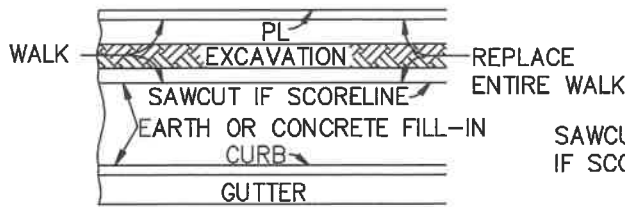

### WALK ADJACENT TO CURB

WALK LESS THAN 5' (1500 mm) WIDE

WALK 5' (1500 mm) WIDE OR MORE

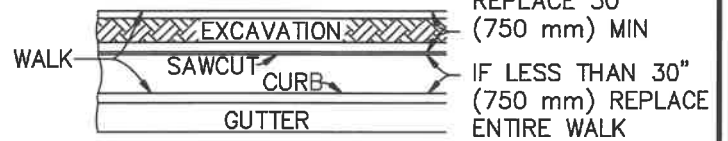

### FILL-IN REPLACEMENT

FILL-IN LESS THAN 5' (1500 mm) WIDE

FILL-IN 5' (1500 mm) WIDE OR MORE

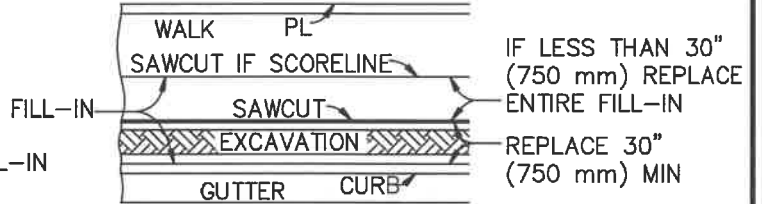
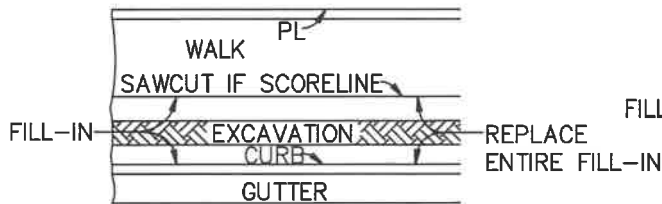

## WALK OR FILL-IN REPLACEMENT FOR EXCAVATIONS MADE NORMAL TO CURB OR PROPERTY LINE

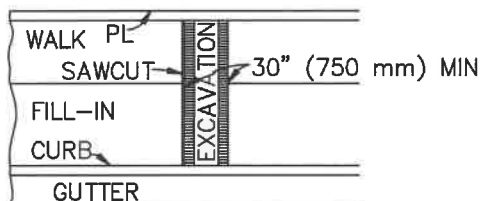

THESE REQUIREMENTS ALSO APPLY TO ENDS OF PARALLEL EXCAVATIONS.

IF AN EXCAVATION FALLS WITHIN 30" (750 mm) OF AN EXPANSION JOINT, CONSTRUCTION JOINT, WEAKENED PLANE JOINT, OR EDGE, THE CONCRETE SHALL BE REMOVED AND REPLACED TO THE JOINT OR EDGE.

IF AN EXCAVATION FALLS WITHIN 12" (300 mm) OF A SCORELINE, THE CONCRETE SHALL BE REMOVED AND REPLACED TO THE SCORELINE. THE SCORELINE SHALL BE SAWCUT BEFORE CONCRETE REMOVAL.

THE MINIMUM LENGTH OF REPLACEMENT IN BOTH CASES SHALL BE 30" (750 mm).

### STANDARD PLANS FOR PUBLIC WORKS CONSTRUCTION

PROMULGATED BY THE  
PUBLIC WORKS STANDARDS INC.  
GREENBOOK COMMITTEE  
1993  
REV. 1996, 2009

## SIDEWALK & DRIVEWAY REPLACEMENT

USE WITH STANDARD SPECIFICATIONS FOR PUBLIC WORKS CONSTRUCTION

STANDARD PLAN

# 113-2

SHEET 1 OF 2

## NOTES

1. CONCRETE WALK, FILL-IN AND DRIVEWAYS REMOVED IN CONNECTION WITH CONSTRUCTION SHALL BE REPLACED TO NEATLY SAWED EDGES. ALL CUTS SHALL BE PARALLEL TO OR PERPENDICULAR TO THE CURB; ON CURVES, THE CUT SHALL BE RADIAL TO THE CURB.
2. DRIVEWAY APRONS IN WHICH THE "W" DISTANCE IS LESS THAN 11' (3300 mm) SHALL BE REPLACED IN THEIR ENTIRETY IF CUT IN ANY AREA.
3. DRIVEWAY APRONS IN WHICH THE "W" DISTANCE IS 11' (3300 mm) OR MORE MAY BE CUT WITHIN THE "W" SECTION. THE MINIMUM REPLACEMENT SHALL BE 30" (750 mm) IN LENGTH. THE MINIMUM DISTANCE ALLOWED BETWEEN SUCH CUTS SHALL BE 14' (4200 mm).
4. DRIVEWAY APRONS IN WHICH THE "W" DISTANCE IS 11' (3300 mm) OR MORE MAY BE CUT IN THE "X" OR "R" SECTION. REPLACEMENT SHALL BE THE ENTIRE "X" OR "R" SECTION.
5. DRIVEWAY APRONS SHALL BE REPLACED FROM THE BACK OF THE CURB TO THE FRONT EDGE OF THE WALK, EXCEPT, WHERE WALK IS ADJACENT TO CURB, REPLACEMENT SHALL BE FROM BACK OF CURB TO BACK OF WALK.
6. WALK PORTIONS OF DRIVEWAYS SHALL BE REPLACED AS SHOWN ABOVE FOR EXCAVATIONS MADE PARALLEL OR NORMAL TO CURB.
7. REPLACEMENT OF THE "X" OR "R" SECTION SHALL MATCH EXISTING CONSTRUCTION.

STANDARD PLANS FOR PUBLIC WORKS CONSTRUCTION

STANDARD PLAN

**SIDEWALK & DRIVEWAY REPLACEMENT**

**113-2**

SHEET 2 OF 2



## **APPENDIX "D"**

### **SOUTH COAST AIR QUALITY MANAGEMENT DISTRICT FOR**

---

**PROJECT Nos. 7031, 85003, & 86004  
BID No. 2024-05  
11TH STREET FLASHING SIGNAL BEACON &  
ALLEY IMPROVEMENTS**

---

(Adopted May 7, 1976) (Amended November 6, 1992)  
(Amended July 9, 1993) (Amended February 14, 1997)  
(Amended December 11, 1998)(Amended April 2, 2004)  
(Amended June 3, 2005)

**RULE 403. FUGITIVE DUST**

(a) Purpose

The purpose of this Rule is to reduce the amount of particulate matter entrained in the ambient air as a result of anthropogenic (man-made) fugitive dust sources by requiring actions to prevent, reduce or mitigate fugitive dust emissions.

(b) Applicability

The provisions of this Rule shall apply to any activity or man-made condition capable of generating fugitive dust.

(c) Definitions

- (1) ACTIVE OPERATIONS means any source capable of generating fugitive dust, including, but not limited to, earth-moving activities, construction/demolition activities, disturbed surface area, or heavy- and light-duty vehicular movement.
- (2) AGGREGATE-RELATED PLANTS are defined as facilities that produce and / or mix sand and gravel and crushed stone.
- (3) AGRICULTURAL HANDBOOK means the region-specific guidance document that has been approved by the Governing Board or hereafter approved by the Executive Officer and the U.S. EPA. For the South Coast Air Basin, the Board-approved region-specific guidance document is the Rule 403 Agricultural Handbook dated December 1998. For the Coachella Valley, the Board-approved region-specific guidance document is the Rule 403 Coachella Valley Agricultural Handbook dated April 2, 2004.
- (4) ANEMOMETERS are devices used to measure wind speed and direction in accordance with the performance standards, and maintenance and calibration criteria as contained in the most recent Rule 403 Implementation Handbook.
- (5) BEST AVAILABLE CONTROL MEASURES means fugitive dust control actions that are set forth in Table 1 of this Rule.

- (6) BULK MATERIAL is sand, gravel, soil, aggregate material less than two inches in length or diameter, and other organic or inorganic particulate matter.
- (7) CEMENT MANUFACTURING FACILITY is any facility that has a cement kiln at the facility.
- (8) CHEMICAL STABILIZERS are any non-toxic chemical dust suppressant which must not be used if prohibited for use by the Regional Water Quality Control Boards, the California Air Resources Board, the U.S. Environmental Protection Agency (U.S. EPA), or any applicable law, rule or regulation. The chemical stabilizers shall meet any specifications, criteria, or tests required by any federal, state, or local water agency. Unless otherwise indicated, the use of a non-toxic chemical stabilizer shall be of sufficient concentration and application frequency to maintain a stabilized surface.
- (9) COMMERCIAL POULTRY RANCH means any building, structure, enclosure, or premises where more than 100 fowl are kept or maintained for the primary purpose of producing eggs or meat for sale or other distribution.
- (10) CONFINED ANIMAL FACILITY means a source or group of sources of air pollution at an agricultural source for the raising of 3,360 or more fowl or 50 or more animals, including but not limited to, any structure, building, installation, farm, corral, coop, feed storage area, milking parlor, or system for the collection, storage, or distribution of solid and liquid manure; if domesticated animals, including horses, sheep, goats, swine, beef cattle, rabbits, chickens, turkeys, or ducks are corralled, penned, or otherwise caused to remain in restricted areas for commercial agricultural purposes and feeding is by means other than grazing.
- (11) CONSTRUCTION/DEMOLITION ACTIVITIES means any on-site mechanical activities conducted in preparation of, or related to, the building, alteration, rehabilitation, demolition or improvement of property, including, but not limited to the following activities: grading, excavation, loading, crushing, cutting, planing, shaping or ground breaking.
- (12) CONTRACTOR means any person who has a contractual arrangement to conduct an active operation for another person.
- (13) DAIRY FARM is an operation on a property, or set of properties that are contiguous or separated only by a public right-of-way, that raises cows or

produces milk from cows for the purpose of making a profit or for a livelihood. Heifer and calf farms are dairy farms.

- (14) **DISTURBED SURFACE AREA** means a portion of the earth's surface which has been physically moved, uncovered, destabilized, or otherwise modified from its undisturbed natural soil condition, thereby increasing the potential for emission of fugitive dust. This definition excludes those areas which have:
- (A) been restored to a natural state, such that the vegetative ground cover and soil characteristics are similar to adjacent or nearby natural conditions;
  - (B) been paved or otherwise covered by a permanent structure; or
  - (C) sustained a vegetative ground cover of at least 70 percent of the native cover for a particular area for at least 30 days.
- (15) **DUST SUPPRESSANTS** are water, hygroscopic materials, or non-toxic chemical stabilizers used as a treatment material to reduce fugitive dust emissions.
- (16) **EARTH-MOVING ACTIVITIES** means the use of any equipment for any activity where soil is being moved or uncovered, and shall include, but not be limited to the following: grading, earth cutting and filling operations, loading or unloading of dirt or bulk materials, adding to or removing from open storage piles of bulk materials, landfill operations, weed abatement through disking, and soil mulching.
- (17) **DUST CONTROL SUPERVISOR** means a person with the authority to expeditiously employ sufficient dust mitigation measures to ensure compliance with all Rule 403 requirements at an active operation.
- (18) **FUGITIVE DUST** means any solid particulate matter that becomes airborne, other than that emitted from an exhaust stack, directly or indirectly as a result of the activities of any person.
- (19) **HIGH WIND CONDITIONS** means that instantaneous wind speeds exceed 25 miles per hour.
- (20) **INACTIVE DISTURBED SURFACE AREA** means any disturbed surface area upon which active operations have not occurred or are not expected to occur for a period of 20 consecutive days.
- (21) **LARGE OPERATIONS** means any active operations on property which contains 50 or more acres of disturbed surface area; or any earth-moving operation with a daily earth-moving or throughput volume of 3,850 cubic

meters (5,000 cubic yards) or more three times during the most recent 365-day period.

- (22) OPEN STORAGE PILE is any accumulation of bulk material, which is not fully enclosed, covered or chemically stabilized, and which attains a height of three feet or more and a total surface area of 150 or more square feet.
- (23) PARTICULATE MATTER means any material, except uncombined water, which exists in a finely divided form as a liquid or solid at standard conditions.
- (24) PAVED ROAD means a public or private improved street, highway, alley, public way, or easement that is covered by typical roadway materials, but excluding access roadways that connect a facility with a public paved roadway and are not open to through traffic. Public paved roads are those open to public access and that are owned by any federal, state, county, municipal or any other governmental or quasi-governmental agencies. Private paved roads are any paved roads not defined as public.
- (25) PM<sub>10</sub> means particulate matter with an aerodynamic diameter smaller than or equal to 10 microns as measured by the applicable State and Federal reference test methods.
- (26) PROPERTY LINE means the boundaries of an area in which either a person causing the emission or a person allowing the emission has the legal use or possession of the property. Where such property is divided into one or more sub-tenancies, the property line(s) shall refer to the boundaries dividing the areas of all sub-tenancies.
- (27) RULE 403 IMPLEMENTATION HANDBOOK means a guidance document that has been approved by the Governing Board on April 2, 2004 or hereafter approved by the Executive Officer and the U.S. EPA.
- (28) SERVICE ROADS are paved or unpaved roads that are used by one or more public agencies for inspection or maintenance of infrastructure and which are not typically used for construction-related activity.
- (29) SIMULTANEOUS SAMPLING means the operation of two PM<sub>10</sub> samplers in such a manner that one sampler is started within five minutes of the other, and each sampler is operated for a consecutive period which must be not less than 290 minutes and not more than 310 minutes.
- (30) SOUTH COAST AIR BASIN means the non-desert portions of Los Angeles, Riverside, and San Bernardino counties and all of Orange

County as defined in California Code of Regulations, Title 17, Section 60104. The area is bounded on the west by the Pacific Ocean, on the north and east by the San Gabriel, San Bernardino, and San Jacinto Mountains, and on the south by the San Diego county line.

- (31) **STABILIZED SURFACE** means any previously disturbed surface area or open storage pile which, through the application of dust suppressants, shows visual or other evidence of surface crusting and is resistant to wind-driven fugitive dust and is demonstrated to be stabilized. Stabilization can be demonstrated by one or more of the applicable test methods contained in the Rule 403 Implementation Handbook.
  - (32) **TRACK-OUT** means any bulk material that adheres to and agglomerates on the exterior surface of motor vehicles, haul trucks, and equipment (including tires) that have been released onto a paved road and can be removed by a vacuum sweeper or a broom sweeper under normal operating conditions.
  - (33) **TYPICAL ROADWAY MATERIALS** means concrete, asphaltic concrete, recycled asphalt, asphalt, or any other material of equivalent performance as determined by the Executive Officer, and the U.S. EPA.
  - (34) **UNPAVED ROADS** means any unsealed or unpaved roads, equipment paths, or travel ways that are not covered by typical roadway materials. Public unpaved roads are any unpaved roadway owned by federal, state, county, municipal or other governmental or quasi-governmental agencies. Private unpaved roads are all other unpaved roadways not defined as public.
  - (35) **VISIBLE ROADWAY DUST** means any sand, soil, dirt, or other solid particulate matter which is visible upon paved road surfaces and which can be removed by a vacuum sweeper or a broom sweeper under normal operating conditions.
  - (36) **WIND-DRIVEN FUGITIVE DUST** means visible emissions from any disturbed surface area which is generated by wind action alone.
  - (37) **WIND GUST** is the maximum instantaneous wind speed as measured by an anemometer.
- (d) **Requirements**
- (1) No person shall cause or allow the emissions of fugitive dust from any active operation, open storage pile, or disturbed surface area such that:

- (A) the dust remains visible in the atmosphere beyond the property line of the emission source; or
  - (B) the dust emission exceeds 20 percent opacity (as determined by the appropriate test method included in the Rule 403 Implementation Handbook), if the dust emission is the result of movement of a motorized vehicle.
- (2) No person shall conduct active operations without utilizing the applicable best available control measures included in Table 1 of this Rule to minimize fugitive dust emissions from each fugitive dust source type within the active operation.
- (3) No person shall cause or allow PM<sub>10</sub> levels to exceed 50 micrograms per cubic meter when determined, by simultaneous sampling, as the difference between upwind and downwind samples collected on high-volume particulate matter samplers or other U.S. EPA-approved equivalent method for PM<sub>10</sub> monitoring. If sampling is conducted, samplers shall be:
- (A) Operated, maintained, and calibrated in accordance with 40 Code of Federal Regulations (CFR), Part 50, Appendix J, or appropriate U.S. EPA-published documents for U.S. EPA-approved equivalent method(s) for PM<sub>10</sub>.
  - (B) Reasonably placed upwind and downwind of key activity areas and as close to the property line as feasible, such that other sources of fugitive dust between the sampler and the property line are minimized.
- (4) No person shall allow track-out to extend 25 feet or more in cumulative length from the point of origin from an active operation. Notwithstanding the preceding, all track-out from an active operation shall be removed at the conclusion of each workday or evening shift.
- (5) No person shall conduct an active operation with a disturbed surface area of five or more acres, or with a daily import or export of 100 cubic yards or more of bulk material without utilizing at least one of the measures listed in subparagraphs (d)(5)(A) through (d)(5)(E) at each vehicle egress from the site to a paved public road.
- (A) Install a pad consisting of washed gravel (minimum-size: one inch) maintained in a clean condition to a depth of at least six inches and extending at least 30 feet wide and at least 50 feet long.

- (B) Pave the surface extending at least 100 feet and at least 20 feet wide.
  - (C) Utilize a wheel shaker/wheel spreading device consisting of raised dividers (rails, pipe, or grates) at least 24 feet long and 10 feet wide to remove bulk material from tires and vehicle undercarriages before vehicles exit the site.
  - (D) Install and utilize a wheel washing system to remove bulk material from tires and vehicle undercarriages before vehicles exit the site.
  - (E) Any other control measures approved by the Executive Officer and the U.S. EPA as equivalent to the actions specified in subparagraphs (d)(5)(A) through (d)(5)(D).
- (6) Beginning January 1, 2006, any person who operates or authorizes the operation of a confined animal facility subject to this Rule shall implement the applicable conservation management practices specified in Table 4 of this Rule.
- (e) Additional Requirements for Large Operations
- (1) Any person who conducts or authorizes the conducting of a large operation subject to this Rule shall implement the applicable actions specified in Table 2 of this Rule at all times and shall implement the applicable actions specified in Table 3 of this Rule when the applicable performance standards can not be met through use of Table 2 actions; and shall:
    - (A) submit a fully executed Large Operation Notification (Form 403 N) to the Executive Officer within 7 days of qualifying as a large operation;
    - (B) include, as part of the notification, the name(s), address(es), and phone number(s) of the person(s) responsible for the submittal, and a description of the operation(s), including a map depicting the location of the site;
    - (C) maintain daily records to document the specific dust control actions taken, maintain such records for a period of not less than three years; and make such records available to the Executive Officer upon request;

- (D) install and maintain project signage with project contact signage that meets the minimum standards of the Rule 403 Implementation Handbook, prior to initiating any earthmoving activities;
  - (E) identify a dust control supervisor that:
    - (i) is employed by or contracted with the property owner or developer;
    - (ii) is on the site or available on-site within 30 minutes during working hours;
    - (iii) has the authority to expeditiously employ sufficient dust mitigation measures to ensure compliance with all Rule requirements;
    - (iv) has completed the AQMD Fugitive Dust Control Class and has been issued a valid Certificate of Completion for the class; and
  - (F) notify the Executive Officer in writing within 30 days after the site no longer qualifies as a large operation as defined by paragraph (c)(18).
- (2) Any Large Operation Notification submitted to the Executive Officer or AQMD-approved dust control plan shall be valid for a period of one year from the date of written acceptance by the Executive Officer. Any Large Operation Notification accepted pursuant to paragraph (e)(1), excluding those submitted by aggregate-related plants and cement manufacturing facilities must be resubmitted annually by the person who conducts or authorizes the conducting of a large operation, at least 30 days prior to the expiration date, or the submittal shall no longer be valid as of the expiration date. If all fugitive dust sources and corresponding control measures or special circumstances remain identical to those identified in the previously accepted submittal or in an AQMD-approved dust control plan, the resubmittal may be a simple statement of no-change (Form 403NC).
- (f) **Compliance Schedule**  
The newly amended provisions of this Rule shall become effective upon adoption. Pursuant to subdivision (e), any existing site that qualifies as a large operation will have 60 days from the date of Rule adoption to comply with the notification and recordkeeping requirements for large operations. Any Large Operation

Notification or AQMD-approved dust control plan which has been accepted prior to the date of adoption of these amendments shall remain in effect and the Large Operation Notification or AQMD-approved dust control plan annual resubmittal date shall be one year from adoption of this Rule amendment.

(g) Exemptions

(1) The provisions of this Rule shall not apply to:

- (A) Dairy farms.
- (B) Confined animal facilities provided that the combined disturbed surface area within one continuous property line is one acre or less.
- (C) Agricultural vegetative crop operations provided that the combined disturbed surface area within one continuous property line and not separated by a paved public road is 10 acres or less.
- (D) Agricultural vegetative crop operations within the South Coast Air Basin, whose combined disturbed surface area includes more than 10 acres provided that the person responsible for such operations:
  - (i) voluntarily implements the conservation management practices contained in the Rule 403 Agricultural Handbook;
  - (ii) completes and maintains the self-monitoring form documenting sufficient conservation management practices, as described in the Rule 403 Agricultural Handbook; and
  - (iii) makes the completed self-monitoring form available to the Executive Officer upon request.
- (E) Agricultural vegetative crop operations outside the South Coast Air Basin whose combined disturbed surface area includes more than 10 acres provided that the person responsible for such operations:
  - (i) voluntarily implements the conservation management practices contained in the Rule 403 Coachella Valley Agricultural Handbook; and
  - (ii) completes and maintains the self-monitoring form documenting sufficient conservation management practices, as described in the Rule 403 Coachella Valley Agricultural Handbook; and
  - (iii) makes the completed self-monitoring form available to the Executive Officer upon request.

- (F) Active operations conducted during emergency life-threatening situations, or in conjunction with any officially declared disaster or state of emergency.
  - (G) Active operations conducted by essential service utilities to provide electricity, natural gas, telephone, water and sewer during periods of service outages and emergency disruptions.
  - (H) Any contractor subsequent to the time the contract ends, provided that such contractor implemented the required control measures during the contractual period.
  - (I) Any grading contractor, for a phase of active operations, subsequent to the contractual completion of that phase of earth-moving activities, provided that the required control measures have been implemented during the entire phase of earth-moving activities, through and including five days after the final grading inspection.
  - (J) Weed abatement operations ordered by a county agricultural commissioner or any state, county, or municipal fire department, provided that:
    - (i) mowing, cutting or other similar process is used which maintains weed stubble at least three inches above the soil; and
    - (ii) any discing or similar operation which cuts into and disturbs the soil, where watering is used prior to initiation of these activities, and a determination is made by the agency issuing the weed abatement order that, due to fire hazard conditions, rocks, or other physical obstructions, it is not practical to meet the conditions specified in clause (g)(1)(H)(i). The provisions this clause shall not exempt the owner of any property from stabilizing, in accordance with paragraph (d)(2), disturbed surface areas which have been created as a result of the weed abatement actions.
  - (K) sandblasting operations.
- (2) The provisions of paragraphs (d)(1) and (d)(3) shall not apply:
- (A) When wind gusts exceed 25 miles per hour, provided that:

- (i) The required Table 3 contingency measures in this Rule are implemented for each applicable fugitive dust source type, and;
    - (ii) records are maintained in accordance with subparagraph (e)(1)(C).
  - (B) To unpaved roads, provided such roads:
    - (i) are used solely for the maintenance of wind-generating equipment; or
    - (ii) are unpaved public alleys as defined in Rule 1186; or
    - (iii) are service roads that meet all of the following criteria:
      - (a) are less than 50 feet in width at all points along the road;
      - (b) are within 25 feet of the property line; and
      - (c) have a traffic volume less than 20 vehicle-trips per day.
  - (C) To any active operation, open storage pile, or disturbed surface area for which necessary fugitive dust preventive or mitigative actions are in conflict with the federal Endangered Species Act, as determined in writing by the State or federal agency responsible for making such determinations.
- (3) The provisions of (d)(2) shall not apply to any aggregate-related plant or cement manufacturing facility that implements the applicable actions specified in Table 2 of this Rule at all times and shall implement the applicable actions specified in Table 3 of this Rule when the applicable performance standards of paragraphs (d)(1) and (d)(3) can not be met through use of Table 2 actions.
  - (4) The provisions of paragraphs (d)(1), (d)(2), and (d)(3) shall not apply to:
    - (A) Blasting operations which have been permitted by the California Division of Industrial Safety; and
    - (B) Motion picture, television, and video production activities when dust emissions are required for visual effects. In order to obtain this exemption, the Executive Officer must receive notification in writing at least 72 hours in advance of any such activity and no nuisance results from such activity.
  - (5) The provisions of paragraph (d)(3) shall not apply if the dust control actions, as specified in Table 2, are implemented on a routine basis for

each applicable fugitive dust source type. To qualify for this exemption, a person must maintain records in accordance with subparagraph (e)(1)(C).

- (6) The provisions of paragraph (d)(4) shall not apply to earth coverings of public paved roadways where such coverings are approved by a local government agency for the protection of the roadway, and where such coverings are used as roadway crossings for haul vehicles provided that such roadway is closed to through traffic and visible roadway dust is removed within one day following the cessation of activities.
- (7) The provisions of subdivision (e) shall not apply to:
  - (A) officially-designated public parks and recreational areas, including national parks, national monuments, national forests, state parks, state recreational areas, and county regional parks.
  - (B) any large operation which is required to submit a dust control plan to any city or county government which has adopted a District-approved dust control ordinance.
  - (C) any large operation subject to Rule 1158, which has an approved dust control plan pursuant to Rule 1158, provided that all sources of fugitive dust are included in the Rule 1158 plan.
- (8) The provisions of subparagraph (e)(1)(A) through (e)(1)(C) shall not apply to any large operation with an AQMD-approved fugitive dust control plan provided that there is no change to the sources and controls as identified in the AQMD-approved fugitive dust control plan.

(h) Fees

Any person conducting active operations for which the Executive Officer conducts upwind/downwind monitoring for PM<sub>10</sub> pursuant to paragraph (d)(3) shall be assessed applicable Ambient Air Analysis Fees pursuant to Rule 304.1. Applicable fees shall be waived for any facility which is exempted from paragraph (d)(3) or meets the requirements of paragraph (d)(3).

**TABLE 1**  
**BEST AVAILABLE CONTROL MEASURES**  
**(Applicable to All Construction Activity Sources)**

Source Category	Control Measure	Guidance
Backfilling	01-1 Stabilize backfill material when not actively handling; and 01-2 Stabilize backfill material during handling; and 01-3 Stabilize soil at completion of activity.	<ul style="list-style-type: none"> <li>✓ Mix backfill soil with water prior to moving</li> <li>✓ Dedicate water truck or high capacity hose to backfilling equipment</li> <li>✓ Empty loader bucket slowly so that no dust plumes are generated</li> <li>✓ Minimize drop height from loader bucket</li> </ul>
Clearing and grubbing	02-1 Maintain stability of soil through pre-watering of site prior to clearing and grubbing; and 02-2 Stabilize soil during clearing and grubbing activities; and 02-3 Stabilize soil immediately after clearing and grubbing activities.	<ul style="list-style-type: none"> <li>✓ Maintain live perennial vegetation where possible</li> <li>✓ Apply water in sufficient quantity to prevent generation of dust plumes</li> </ul>
Clearing forms	03-1 Use water spray to clear forms; or 03-2 Use sweeping and water spray to clear forms; or 03-3 Use vacuum system to clear forms.	<ul style="list-style-type: none"> <li>✓ Use of high pressure air to clear forms may cause exceedance of Rule requirements</li> </ul>
Crushing	04-1 Stabilize surface soils prior to operation of support equipment; and 04-2 Stabilize material after crushing.	<ul style="list-style-type: none"> <li>✓ Follow permit conditions for crushing equipment</li> <li>✓ Pre-water material prior to loading into crusher</li> <li>✓ Monitor crusher emissions opacity</li> <li>✓ Apply water to crushed material to prevent dust plumes</li> </ul>

**TABLE 1**  
**BEST AVAILABLE CONTROL MEASURES**  
**(Applicable to All Construction Activity Sources)**

<b>Source Category</b>	<b>Control Measure</b>	<b>Guidance</b>
Cut and fill	05-1 Pre-water soils prior to cut and fill activities; and 05-2 Stabilize soil during and after cut and fill activities.	<ul style="list-style-type: none"> <li>✓ For large sites, pre-water with sprinklers or water trucks and allow time for penetration</li> <li>✓ Use water trucks/pulls to water soils to depth of cut prior to subsequent cuts</li> </ul>
Demolition – mechanical/manual	06-1 Stabilize wind erodible surfaces to reduce dust; and 06-2 Stabilize surface soil where support equipment and vehicles will operate; and 06-3 Stabilize loose soil and demolition debris; and 06-4 Comply with AQMD Rule 1403.	<ul style="list-style-type: none"> <li>✓ Apply water in sufficient quantities to prevent the generation of visible dust plumes</li> </ul>
Disturbed soil	07-1 Stabilize disturbed soil throughout the construction site; and 07-2 Stabilize disturbed soil between structures	<ul style="list-style-type: none"> <li>✓ Limit vehicular traffic and disturbances on soils where possible</li> <li>✓ If interior block walls are planned, install as early as possible</li> <li>✓ Apply water or a stabilizing agent in sufficient quantities to prevent the generation of visible dust plumes</li> </ul>
Earth-moving activities	08-1 Pre-apply water to depth of proposed cuts; and 08-2 Re-apply water as necessary to maintain soils in a damp condition and to ensure that visible emissions do not exceed 100 feet in any direction; and 08-3 Stabilize soils once earth-moving activities are complete.	<ul style="list-style-type: none"> <li>✓ Grade each project phase separately, timed to coincide with construction phase</li> <li>✓ Upwind fencing can prevent material movement on site</li> <li>✓ Apply water or a stabilizing agent in sufficient quantities to prevent the generation of visible dust plumes</li> </ul>

**TABLE 1**  
**BEST AVAILABLE CONTROL MEASURES**  
**(Applicable to All Construction Activity Sources)**

Source Category	Control Measure	Guidance
Importing/exporting of bulk materials	09-1 Stabilize material while loading to reduce fugitive dust emissions; and 09-2 Maintain at least six inches of freeboard on haul vehicles; and 09-3 Stabilize material while transporting to reduce fugitive dust emissions; and 09-4 Stabilize material while unloading to reduce fugitive dust emissions; and 09-5 Comply with Vehicle Code Section 23114.	<ul style="list-style-type: none"> <li>✓ Use tarps or other suitable enclosures on haul trucks</li> <li>✓ Check belly-dump truck seals regularly and remove any trapped rocks to prevent spillage</li> <li>✓ Comply with track-out prevention/mitigation requirements</li> <li>✓ Provide water while loading and unloading to reduce visible dust plumes</li> </ul>
Landscaping	10-1 Stabilize soils, materials, slopes	<ul style="list-style-type: none"> <li>✓ Apply water to materials to stabilize</li> <li>✓ Maintain materials in a crusted condition</li> <li>✓ Maintain effective cover over materials</li> <li>✓ Stabilize sloping surfaces using soil binders until vegetation or ground cover can effectively stabilize the slopes</li> <li>✓ Hydroseed prior to rain season</li> </ul>
Road shoulder maintenance	11-1 Apply water to unpaved shoulders prior to clearing; and 11-2 Apply chemical dust suppressants and/or washed gravel to maintain a stabilized surface after completing road shoulder maintenance.	<ul style="list-style-type: none"> <li>✓ Installation of curbing and/or paving of road shoulders can reduce recurring maintenance costs</li> <li>✓ Use of chemical dust suppressants can inhibit vegetation growth and reduce future road shoulder maintenance costs</li> </ul>

**TABLE 1**  
**BEST AVAILABLE CONTROL MEASURES**  
**(Applicable to All Construction Activity Sources)**

Source Category	Control Measure	Guidance
Screening	12-1 Pre-water material prior to screening; and 12-2 Limit fugitive dust emissions to opacity and plume length standards; and 12-3 Stabilize material immediately after screening.	<ul style="list-style-type: none"> <li>✓ Dedicate water truck or high capacity hose to screening operation</li> <li>✓ Drop material through the screen slowly and minimize drop height</li> <li>✓ Install wind barrier with a porosity of no more than 50% upwind of screen to the height of the drop point</li> </ul>
Staging areas	13-1 Stabilize staging areas during use; and 13-2 Stabilize staging area soils at project completion.	<ul style="list-style-type: none"> <li>✓ Limit size of staging area</li> <li>✓ Limit vehicle speeds to 15 miles per hour</li> <li>✓ Limit number and size of staging area entrances/exists</li> </ul>
Stockpiles/ Bulk Material Handling	14-1 Stabilize stockpiled materials. 14-2 Stockpiles within 100 yards of off-site occupied buildings must not be greater than eight feet in height; or must have a road bladed to the top to allow water truck access or must have an operational water irrigation system that is capable of complete stockpile coverage.	<ul style="list-style-type: none"> <li>✓ Add or remove material from the downwind portion of the storage pile</li> <li>✓ Maintain storage piles to avoid steep sides or faces</li> </ul>

**TABLE 1**  
**BEST AVAILABLE CONTROL MEASURES**  
**(Applicable to All Construction Activity Sources)**

Source Category	Control Measure	Guidance
Traffic areas for construction activities	15-1 Stabilize all off-road traffic and parking areas; and 15-2 Stabilize all haul routes; and 15-3 Direct construction traffic over established haul routes.	<ul style="list-style-type: none"> <li>✓ Apply gravel/paving to all haul routes as soon as possible to all future roadway areas</li> <li>✓ Barriers can be used to ensure vehicles are only used on established parking areas/haul routes</li> </ul>
Trenching	16-1 Stabilize surface soils where trencher or excavator and support equipment will operate; and 16-2 Stabilize soils at the completion of trenching activities.	<ul style="list-style-type: none"> <li>✓ Pre-watering of soils prior to trenching is an effective preventive measure. For deep trenching activities, pre-trench to 18 inches soak soils via the pre-trench and resuming trenching</li> <li>✓ Washing mud and soils from equipment at the conclusion of trenching activities can prevent crusting and drying of soil on equipment</li> </ul>
Truck loading	17-1 Pre-water material prior to loading; and 17-2 Ensure that freeboard exceeds six inches (CVC 23114)	<ul style="list-style-type: none"> <li>✓ Empty loader bucket such that no visible dust plumes are created</li> <li>✓ Ensure that the loader bucket is close to the truck to minimize drop height while loading</li> </ul>
Turf Overseeding	18-1 Apply sufficient water immediately prior to conducting turf vacuuming activities to meet opacity and plume length standards; and 18-2 Cover haul vehicles prior to exiting the site.	<ul style="list-style-type: none"> <li>✓ Haul waste material immediately off-site</li> </ul>

**TABLE 1**  
**BEST AVAILABLE CONTROL MEASURES**  
**(Applicable to All Construction Activity Sources)**

<b>Source Category</b>	<b>Control Measure</b>	<b>Guidance</b>
Unpaved roads/parking lots	19-1 Stabilize soils to meet the applicable performance standards; and 19-2 Limit vehicular travel to established unpaved roads (haul routes) and unpaved parking lots.	✓ Restricting vehicular access to established unpaved travel paths and parking lots can reduce stabilization requirements
Vacant land	20-1 In instances where vacant lots are 0.10 acre or larger and have a cumulative area of 500 square feet or more that are driven over and/or used by motor vehicles and/or off-road vehicles, prevent motor vehicle and/or off-road vehicle trespassing, parking and/or access by installing barriers, curbs, fences, gates, posts, signs, shrubs, trees or other effective control measures.	

**Table 2  
DUST CONTROL MEASURES FOR LARGE OPERATIONS**

<b>FUGITIVE DUST SOURCE CATEGORY</b>	<b>CONTROL ACTIONS</b>
<p><b>Earth-moving (except construction cutting and filling areas, and mining operations)</b></p>	<p>(1a) Maintain soil moisture content at a minimum of 12 percent, as determined by ASTM method D-2216, or other equivalent method approved by the Executive Officer, the California Air Resources Board, and the U.S. EPA. Two soil moisture evaluations must be conducted during the first three hours of active operations during a calendar day, and two such evaluations each subsequent four-hour period of active operations; OR</p> <p>(1a-1) For any earth-moving which is more than 100 feet from all property lines, conduct watering as necessary to prevent visible dust emissions from exceeding 100 feet in length in any direction.</p>
<p><b>Earth-moving: Construction fill areas:</b></p>	<p>(1b) Maintain soil moisture content at a minimum of 12 percent, as determined by ASTM method D-2216, or other equivalent method approved by the Executive Officer, the California Air Resources Board, and the U.S. EPA. For areas which have an optimum moisture content for compaction of less than 12 percent, as determined by ASTM Method 1557 or other equivalent method approved by the Executive Officer and the California Air Resources Board and the U.S. EPA, complete the compaction process as expeditiously as possible after achieving at least 70 percent of the optimum soil moisture content. Two soil moisture evaluations must be conducted during the first three hours of active operations during a calendar day, and two such evaluations during each subsequent four-hour period of active operations.</p>

Table 2 (Continued)

<b>FUGITIVE DUST SOURCE CATEGORY</b>	<b>CONTROL ACTIONS</b>
<b>Earth-moving: Construction cut areas and mining operations:</b>	(1c) Conduct watering as necessary to prevent visible emissions from extending more than 100 feet beyond the active cut or mining area unless the area is inaccessible to watering vehicles due to slope conditions or other safety factors.
<b>Disturbed surface areas (except completed grading areas)</b>	(2a/b) Apply dust suppression in sufficient quantity and frequency to maintain a stabilized surface. Any areas which cannot be stabilized, as evidenced by wind driven fugitive dust must have an application of water at least twice per day to at least 80 percent of the unstabilized area.
<b>Disturbed surface areas: Completed grading areas</b>	(2c) Apply chemical stabilizers within five working days of grading completion; OR  (2d) Take actions (3a) or (3c) specified for inactive disturbed surface areas.
<b>Inactive disturbed surface areas</b>	(3a) Apply water to at least 80 percent of all inactive disturbed surface areas on a daily basis when there is evidence of wind driven fugitive dust, excluding any areas which are inaccessible to watering vehicles due to excessive slope or other safety conditions; OR  (3b) Apply dust suppressants in sufficient quantity and frequency to maintain a stabilized surface; OR  (3c) Establish a vegetative ground cover within 21 days after active operations have ceased. Ground cover must be of sufficient density to expose less than 30 percent of unstabilized ground within 90 days of planting, and at all times thereafter; OR  (3d) Utilize any combination of control actions (3a), (3b), and (3c) such that, in total, these actions apply to all inactive disturbed surface areas.

Table 2 (Continued)

<b>FUGITIVE DUST SOURCE CATEGORY</b>	<b>CONTROL ACTIONS</b>
<b>Unpaved Roads</b>	<p>(4a) Water all roads used for any vehicular traffic at least once per every two hours of active operations [3 times per normal 8 hour work day]; OR</p> <p>(4b) Water all roads used for any vehicular traffic once daily and restrict vehicle speeds to 15 miles per hour; OR</p> <p>(4c) Apply a chemical stabilizer to all unpaved road surfaces in sufficient quantity and frequency to maintain a stabilized surface.</p>
<b>Open storage piles</b>	<p>(5a) Apply chemical stabilizers; OR</p> <p>(5b) Apply water to at least 80 percent of the surface area of all open storage piles on a daily basis when there is evidence of wind driven fugitive dust; OR</p> <p>(5c) Install temporary coverings; OR</p> <p>(5d) Install a three-sided enclosure with walls with no more than 50 percent porosity which extend, at a minimum, to the top of the pile. This option may only be used at aggregate-related plants or at cement manufacturing facilities.</p>
<b>All Categories</b>	<p>(6a) Any other control measures approved by the Executive Officer and the U.S. EPA as equivalent to the methods specified in Table 2 may be used.</p>

**TABLE 3**  
**CONTINGENCY CONTROL MEASURES FOR LARGE OPERATIONS**

<b>FUGITIVE DUST SOURCE CATEGORY</b>	<b>CONTROL MEASURES</b>
<b>Earth-moving</b>	(1A) Cease all active operations; OR (2A) Apply water to soil not more than 15 minutes prior to moving such soil.
<b>Disturbed surface areas</b>	(0B) On the last day of active operations prior to a weekend, holiday, or any other period when active operations will not occur for not more than four consecutive days: apply water with a mixture of chemical stabilizer diluted to not less than 1/20 of the concentration required to maintain a stabilized surface for a period of six months; OR (1B) Apply chemical stabilizers prior to wind event; OR (2B) Apply water to all unstabilized disturbed areas 3 times per day. If there is any evidence of wind driven fugitive dust, watering frequency is increased to a minimum of four times per day; OR (3B) Take the actions specified in Table 2, Item (3c); OR (4B) Utilize any combination of control actions (1B), (2B), and (3B) such that, in total, these actions apply to all disturbed surface areas.
<b>Unpaved roads</b>	(1C) Apply chemical stabilizers prior to wind event; OR (2C) Apply water twice per hour during active operation; OR (3C) Stop all vehicular traffic.
<b>Open storage piles</b>	(1D) Apply water twice per hour; OR (2D) Install temporary coverings.
<b>Paved road track-out</b>	(1E) Cover all haul vehicles; OR (2E) Comply with the vehicle freeboard requirements of Section 23114 of the California Vehicle Code for both public and private roads.
<b>All Categories</b>	(1F) Any other control measures approved by the Executive Officer and the U.S. EPA as equivalent to the methods specified in Table 3 may be used.

**Table 4**  
**(Conservation Management Practices for Confined Animal Facilities)**

<b>SOURCE CATEGORY</b>	<b>CONSERVATION MANAGEMENT PRACTICES</b>
<b>Manure Handling</b>  <b>(Only applicable to Commercial Poultry Ranches)</b>	(1a) Cover manure prior to removing material off-site; AND (1b) Spread the manure before 11:00 AM and when wind conditions are less than 25 miles per hour; AND (1c) Utilize coning and drying manure management by removing manure at laying hen houses at least twice per year and maintain a base of no less than 6 inches of dry manure after clean out; or in lieu of complying with conservation management practice (1c), comply with conservation management practice (1d). (1d) Utilize frequent manure removal by removing the manure from laying hen houses at least every seven days and immediately thin bed dry the material.
<b>Feedstock Handling</b>	(2a) Utilize a sock or boot on the feed truck auger when filling feed storage bins.
<b>Disturbed Surfaces</b>	(3a) Maintain at least 70 percent vegetative cover on vacant portions of the facility; OR (3b) Utilize conservation tillage practices to manage the amount, orientation and distribution of crop and other plant residues on the soil surface year-round, while growing crops (if applicable) in narrow slots or tilled strips; OR (3c) Apply dust suppressants in sufficient concentrations and frequencies to maintain a stabilized surface.
<b>Unpaved Roads</b>	(4a) Restrict access to private unpaved roads either through signage or physical access restrictions and control vehicular speeds to no more than 15 miles per hour through worker notifications, signage, or any other necessary means; OR (4b) Cover frequently traveled unpaved roads with low silt content material (i.e., asphalt, concrete, recycled road base, or gravel to a minimum depth of four inches); OR (4c) Treat unpaved roads with water, mulch, chemical dust suppressants or other cover to maintain a stabilized surface.
<b>Equipment Parking Areas</b>	(5a) Apply dust suppressants in sufficient quantity and frequency to maintain a stabilized surface; OR (5b) Apply material with low silt content (i.e., asphalt, concrete, recycled road base, or gravel to a depth of four inches).



## **APPENDIX "E"**

# **TRUCK ACCESS PLAN TRUCK ROUTES FOR**

---

**PROJECT Nos. 7031, 85003, & 86004  
BID No. 2024-05  
11TH STREET FLASHING SIGNAL BEACON &  
ALLEY IMPROVEMENTS**

---



**Development Services Department  
Engineering Division**

Telephone (909) 931-4137

Facsimile (909) 931-4321

Revision Date: October 24, 2011

**Construction Traffic (Truck) Access Plan**

Project Name: \_\_\_\_\_ Construction Permit # \_\_\_\_\_  
(Tract/Parcel Map Site Plan or CUP #)

Project Location: \_\_\_\_\_

Company Name: \_\_\_\_\_

Contact Person: \_\_\_\_\_

Company Address: \_\_\_\_\_

Company Telephone: \_\_\_\_\_ Fax: \_\_\_\_\_

Company Email: \_\_\_\_\_

Construction traffic (truck) access to and from the above project site is limited to the following streets:

\_\_\_\_\_  
\_\_\_\_\_  
\_\_\_\_\_  
\_\_\_\_\_

Trucks are restricted to the approved City Of Upland truck routes except as specified above.

This plan is valid for truck traffic associated with delivery of common construction material or removal of earthen materials during grading operations. Trucks or loads exceeding the weight or size limitations as specified in Section 35000 of the California Vehicle Code may require a special permit.

Applicant Signature: \_\_\_\_\_ Date: \_\_\_\_\_

Applicant Name: (Please Print) \_\_\_\_\_

Approved By: \_\_\_\_\_ Date: \_\_\_\_\_

Routing:

- Applicant     PD Traffic Division     Project File     PW Inspectors     PW Transportation

# CITY OF UPLAND TRUCK ROUTES & RESTRICTED STREETS

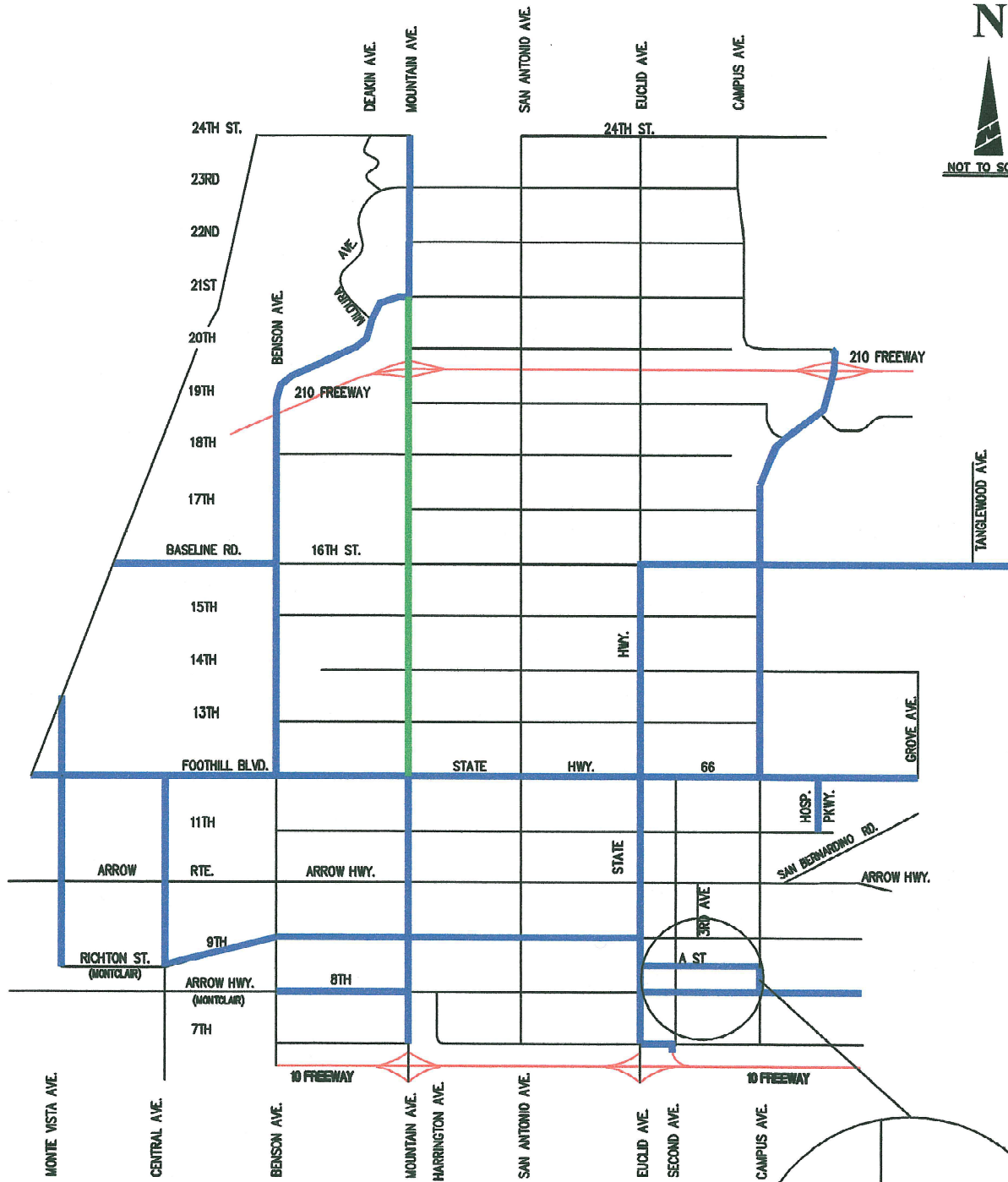

### LEGEND

- █ UNRESTRICTED STREETS, WEIGHT LIMIT PER VEHICLE CODE.
- █ RESTRICTED TO 18 TONS.
- █ ALL OTHERS RESTRICTED TO 5 TONS

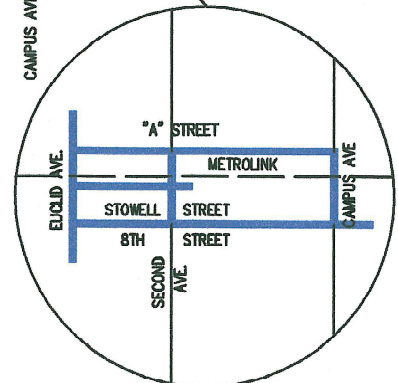



## **APPENDIX "F"**

### **BEST MANAGEMENT PRACTICES FOR**

---

**PROJECT Nos. 7031, 85003, & 86004  
BID No. 2024-05  
11TH STREET FLASHING SIGNAL BEACON &  
ALLEY IMPROVEMENTS**

---

# Stabilized Construction Entrance/Exit TC-1

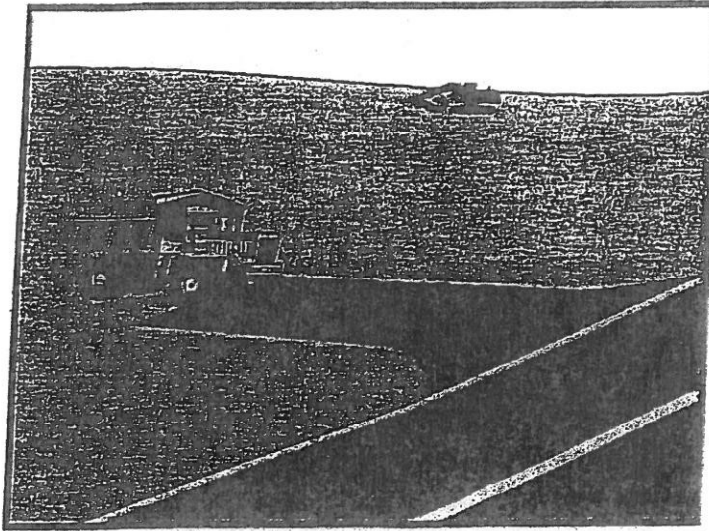

## Description and Purpose

A stabilized construction access is defined by a point of entrance/exit to a construction site that is stabilized to reduce the tracking of mud and dirt onto public roads by construction vehicles.

## Suitable Applications

Use at construction sites:

- Where dirt or mud can be tracked onto public roads.
- Adjacent to water bodies.
- Where poor soils are encountered.
- Where dust is a problem during dry weather conditions.

## Limitations

- Entrances and exits require periodic top dressing with additional stones.
- This BMP should be used in conjunction with street sweeping on adjacent public right of way.
- Entrances and exits should be constructed on level ground only.
- Stabilized construction entrances are rather expensive to construct and when a wash rack is included, a sediment trap of some kind must also be provided to collect wash water runoff.

## Objectives

EC	Erosion Control	<input checked="" type="checkbox"/>
SE	Sediment Control	<input checked="" type="checkbox"/>
TC	Tracking Control	<input checked="" type="checkbox"/>
WE	Wind Erosion Control	
NS	Non-Stormwater Management Control	
WM	Waste Management and Materials Pollution Control	

## Legend:

- Primary Objective
- Secondary Objective

## Targeted Constituents

Sediment	<input checked="" type="checkbox"/>
Nutrients	
Trash	
Metals	
Bacteria	
Oil and Grease	
Organics	

## Potential Alternatives

None



# Stabilized Construction Entrance/Exit TC-1

## **Implementation**

### *General*

A stabilized construction entrance is a pad of aggregate underlain with filter cloth located at any point where traffic will be entering or leaving a construction site to or from a public right of way, street, alley, sidewalk, or parking area. The purpose of a stabilized construction entrance is to reduce or eliminate the tracking of sediment onto public rights of way or streets. Reducing tracking of sediments and other pollutants onto paved roads helps prevent deposition of sediments into local storm drains and production of airborne dust.

Where traffic will be entering or leaving the construction site, a stabilized construction entrance should be used. NPDES permits require that appropriate measures be implemented to prevent tracking of sediments onto paved roadways, where a significant source of sediments is derived from mud and dirt carried out from unpaved roads and construction sites.

Stabilized construction entrances are moderately effective in removing sediment from equipment leaving a construction site. The entrance should be built on level ground. Advantages of the Stabilized Construction Entrance/Exit is that it does remove some sediment from equipment and serves to channel construction traffic in and out of the site at specified locations. Efficiency is greatly increased when a washing rack is included as part of a stabilized construction entrance/exit.

### *Design and Layout*

- Construct on level ground where possible.
- Select 3 to 6 in. diameter stones.
- Use minimum depth of stones of 12 in. or as recommended by soils engineer.
- Construct length of 50 ft minimum, and 30 ft minimum width.
- Rumble racks constructed of steel panels with ridges and installed in the stabilized entrance/exit will help remove additional sediment and to keep adjacent streets clean.
- Provide ample turning radii as part of the entrance.
- Limit the points of entrance/exit to the construction site.
- Limit speed of vehicles to control dust.
- Properly grade each construction entrance/exit to prevent runoff from leaving the construction site.
- Route runoff from stabilized entrances/exits through a sediment trapping device before discharge.
- Design stabilized entrance/exit to support heaviest vehicles and equipment that will use it.
- Select construction access stabilization (aggregate, asphaltic concrete, concrete) based on longevity, required performance, and site conditions. Do not use asphalt concrete (AC) grindings for stabilized construction access/roadway.

## **Stabilized Construction Entrance/Exit TC-1**

- If aggregate is selected, place crushed aggregate over geotextile fabric to at least 12 in. depth, or place aggregate to a depth recommended by a geotechnical engineer. A crushed aggregate greater than 3 in. but smaller than 6 in. should be used.
- Designate combination or single purpose entrances and exits to the construction site.
- Require that all employees, subcontractors, and suppliers utilize the stabilized construction access.
- Implement SE-7, Street Sweeping and Vacuuming, as needed.
- All exit locations intended to be used for more than a two-week period should have stabilized construction entrance/exit BMPs.

### **Inspection and Maintenance**

- Inspect and verify that activity-based BMPs are in place prior to the commencement of associated activities. While activities associated with the BMPs are under way, inspect weekly during the rainy season and of two-week intervals in the non-rainy season to verify continued BMP implementation.
- Inspect local roads adjacent to the site daily. Sweep or vacuum to remove visible accumulated sediment.
- Remove aggregate, separate and dispose of sediment if construction entrance/exit is clogged with sediment.
- Keep all temporary roadway ditches clear.
- Check for damage and repair as needed.
- Replace gravel material when surface voids are visible.
- Remove all sediment deposited on paved roadways within 24 hours.
- Remove gravel and filter fabric at completion of construction

### **Costs**

Average annual cost for installation and maintenance may vary from \$1,200 to \$4,800 each, averaging \$2,400 per entrance. Costs will increase with addition of washing rack, and sediment trap. With wash rack, costs range from \$1,200 - \$6,000 each, averaging \$3,600 per entrance.

### **References**

Manual of Standards of Erosion and Sediment Control Measures, Association of Bay Area Governments, May 1995.

National Management Measures to Control Nonpoint Source Pollution from Urban Areas, USEPA Agency, 2002.

Proposed Guidance Specifying Management Measures for Sources of Nonpoint Pollution in Coastal Waters, Work Group Working Paper, USEPA, April 1992.

## Stabilized Construction Entrance/Exit TC-1

Stormwater Quality Handbooks Construction Site Best Management Practices (BMPs) Manual, State of California Department of Transportation (Caltrans), November 2000.

Stormwater Management of the Puget Sound Basin, Technical Manual, Publication #91-75, Washington State Department of Ecology, February 1992.

Virginia Erosion and Sedimentation Control Handbook, Virginia Department of Conservation and Recreation, Division of Soil and Water Conservation, 1991.

Guidance Specifying Management Measures for Nonpoint Pollution in Coastal Waters, EPA 840-B-9-002, USEPA, Office of Water, Washington, DC, 1993.

Water Quality Management Plan for the Lake Tahoe Region, Volume II, Handbook of Management Practices, Tahoe Regional Planning Agency, November 1988.

# Stabilized Construction Entrance/Exit TC-1

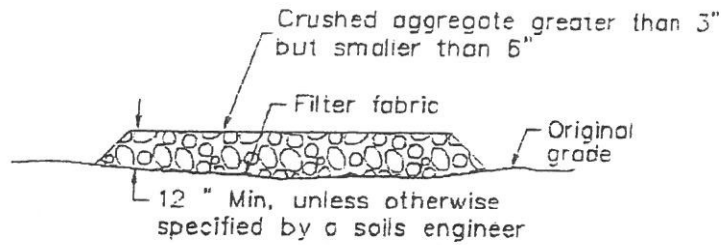

SECTION B-B  
NTS

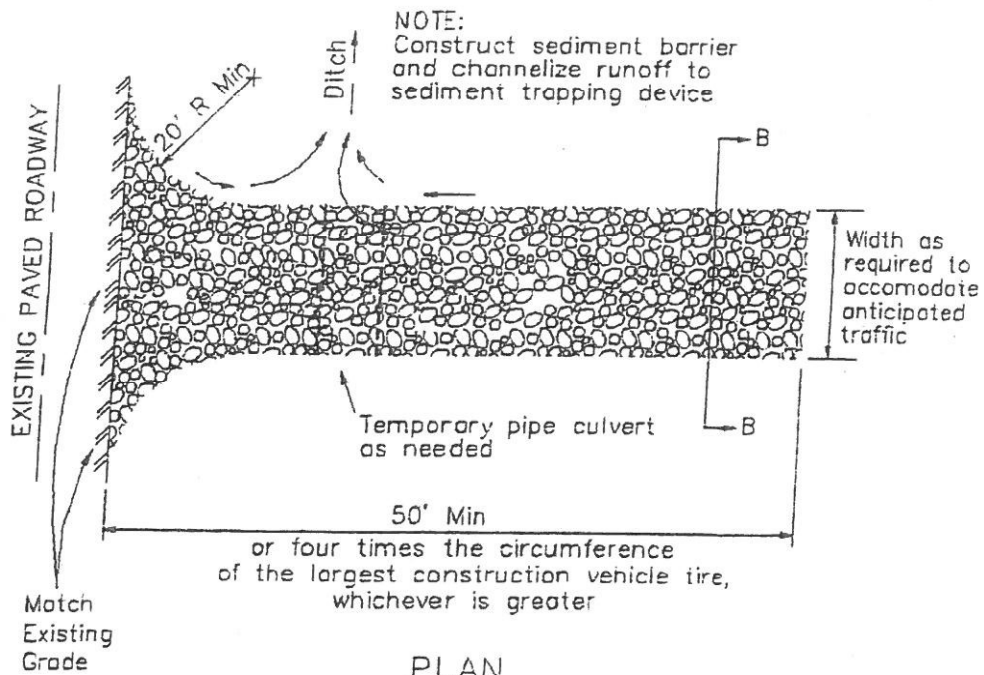

PLAN  
NTS

# Stabilized Construction Entrance/Exit TC-1

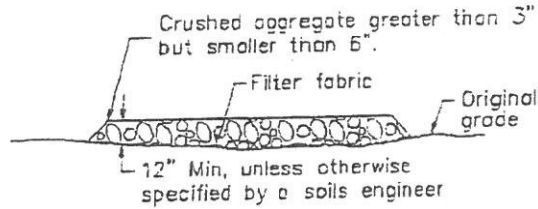

**SECTION B-B**  
NTS

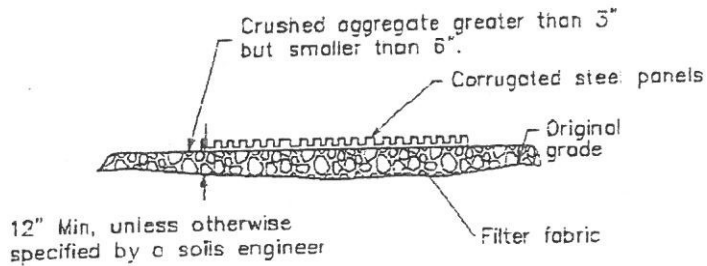

**SECTION A-A**  
NOT TO SCALE

NOTE:  
Construct sediment barrier and channelize runoff to sediment trapping device

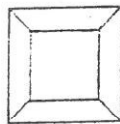

Sediment trapping device

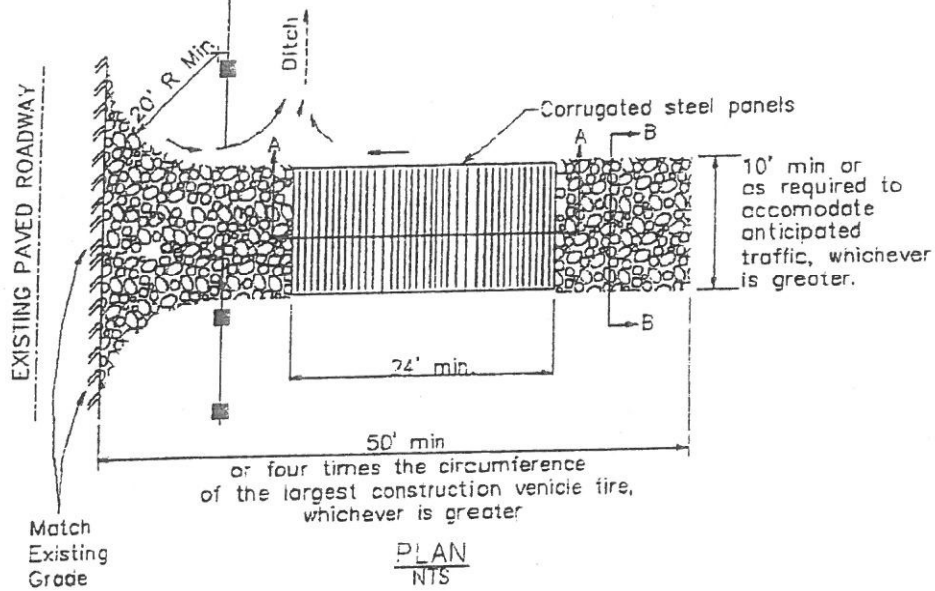

# Stabilized Construction Roadway

TC-2

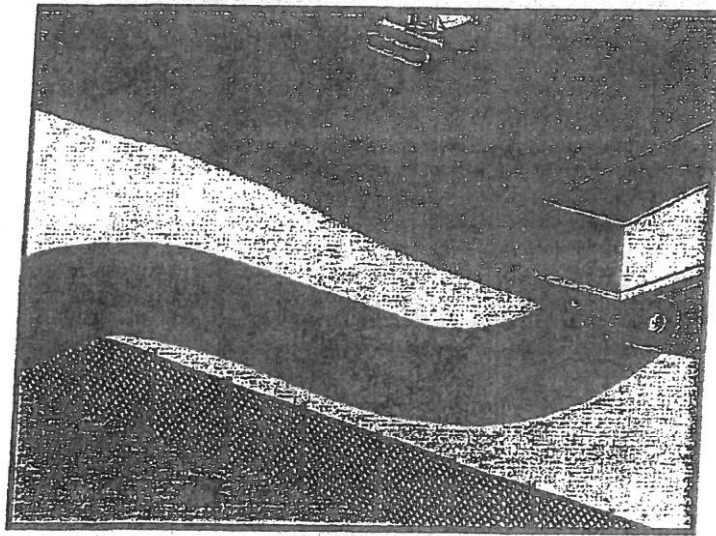

## Objectives

EC	Erosion Control	<input checked="" type="checkbox"/>
SE	Sediment Control	<input checked="" type="checkbox"/>
TC	Tracking Control	<input checked="" type="checkbox"/>
WE	Wind Erosion Control	
NS	Non-Stormwater Management Control	
WM	Waste Management and Materials Pollution Control	

## Legend:

- Primary Objective
- Secondary Objective

## Targeted Constituents

Sediment	<input checked="" type="checkbox"/>
Nutrients	
Trash	
Metals	
Bacteria	
Oil and Grease	
Organics	

## Potential Alternatives

None

## Description and Purpose

Access roads, subdivision roads, parking areas, and other onsite vehicle transportation routes should be stabilized immediately after grading, and frequently maintained to prevent erosion and control dust.

## Suitable Applications

This BMP should be applied for the following conditions:

- Temporary Construction Traffic:
  - Phased construction projects and offsite road access
  - Construction during wet weather
- Construction roadways and detour roads:
  - Where mud tracking is a problem during wet weather
  - Where dust is a problem during dry weather
  - Adjacent to water bodies
  - Where poor soils are encountered

## Limitations

- The roadway must be removed or paved when construction is complete.



- Stabilize roadway using aggregate, asphalt concrete, or concrete based on longevity, required performance, and site conditions. The use of cold mix asphalt or asphalt concrete (AC) grindings for stabilized construction roadway is not allowed.
- Coordinate materials with those used for stabilized construction entrance/exit points.
- If aggregate is selected, place crushed aggregate over geotextile fabric to at least 12 in. depth. A crushed aggregate greater than 3 in. but smaller than 6 in. should be used.

## Inspection and Maintenance

- Inspect and verify that activity-based BMPs are in place prior to the commencement of associated activities. While activities associated with the BMP are under way, inspect weekly during the rainy season and of two-week intervals in the non-rainy season to verify continued BMP implementation.
- Keep all temporary roadway ditches clear.
- When no longer required, remove stabilized construction roadway and re-grade and repair slopes.
- Periodically apply additional aggregate on gravel roads.
- Active dirt construction roads are commonly watered three or more times per day during the dry season.

## Costs

Gravel construction roads are moderately expensive, but cost is often balanced by reductions in construction delay. No additional costs for dust control on construction roads should be required above that needed to meet local air quality requirements.

## References

Blueprint for a Clean Bay: Best Management Practices to Prevent Stormwater Pollution from Construction Related Activities; Santa Clara Valley Nonpoint Source Pollution Control Program, 1995.

Coastal Nonpoint Pollution Control Program; Program Development and Approval Guidance, Working Group, Working Paper: USEPA, April 1992.

Manual of Standards of Erosion and Sediment Control Measures, Association of Bay Area Governments, May 1995.

Stormwater Quality Handbooks Construction Site Best Management Practices (BMPs) Manual, State of California Department of Transportation (Caltrans), November 2000.

Stormwater Management for Construction Activities, Developing Pollution Prevention Plans and Best Management Practices, EPA 832-R-92005; USEPA, April 1992.

Stormwater Management of the Puget Sound Basin, Technical Manual, Publication #91-75, Washington State Department of Ecology, February 1992.

## **TC-2      Stabilized Construction Roadway**

Virginia Erosion and Sedimentation Control Handbook, Virginia Department of Conservation and Recreation, Division of Soil and Water Conservation, 1991.

Water Quality Management Plan for the Lake Tahoe Region, Volume II, Handbook of Management Practices, Tahoe Regional Planning Agency, November 1988.

# Silt Fence

SE-1

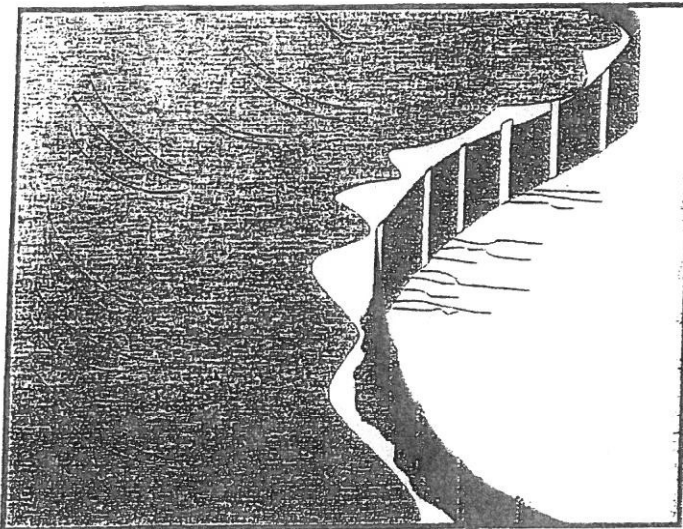

## Description and Purpose

A silt fence is made of a filter fabric that has been entrenched, attached to supporting poles, and sometimes backed by a plastic or wire mesh for support. The silt fence detains sediment-laden water, promoting sedimentation behind the fence.

## Suitable Applications

Silt fences are suitable for perimeter control, placed below areas where sheet flows discharge from the site. They should also be used as interior controls below disturbed areas where runoff may occur in the form of sheet and rill erosion. Silt fences are generally ineffective in locations where the flow is concentrated and are only applicable for sheet or overland flows. Silt fences are most effective when used in combination with erosion controls. Suitable applications include:

- Along the perimeter of a project.
- Below the toe or down slope of exposed and erodible slopes.
- Along streams and channels.
- Around temporary spoil areas and stockpiles.
- Below other small cleared areas.

## Limitations

- Do not use in streams, channels, drain inlets, or anywhere flow is concentrated.

## Objectives

EC	Erosion Control	
SE	Sediment Control	<input checked="" type="checkbox"/>
TR	Tracking Control	
WE	Wind Erosion Control	
NS	Non-Stormwater Management Control	
WM	Waste Management and Materials Pollution Control	

## Legend:

- Primary Objective
- Secondary Objective

## Targeted Constituents

Sediment	<input checked="" type="checkbox"/>
Nutrients	
Trash	
Metals	
Bacteria	
Oil and Grease	
Organics	

## Potential Alternatives

- SE-5 Fiber Rolls
- SE-6 Gravel Bag Berm
- SE-8 Sandbag Barrier
- SE-9 Straw Bale Barrier



- Do not use in locations where ponded water may cause flooding.
- Do not place fence on a slope, or across any contour line. If not installed at the same elevation throughout, silt fences will create erosion.
- Filter fences will create a temporary sedimentation pond on the upstream side of the fence and may cause temporary flooding. Fences not constructed on a level contour will be overtopped by concentrated flow resulting in failure of the filter fence.
- Improperly installed fences are subject to failure from undercutting, overlapping, or collapsing.
  - Not effective unless trenched and keyed in.
  - Not intended for use as mid-slope protection on slopes greater than 4:1 (H:V).
  - Do not allow water depth to exceed 1.5 ft at any point.

### Implementation

#### *General*

A silt fence is a temporary sediment barrier consisting of filter fabric stretched across and attached to supporting posts, entrenched, and, depending upon the strength of fabric used, supported with plastic or wire mesh fence. Silt fences trap sediment by intercepting and detaining small amounts of sediment-laden runoff from disturbed areas in order to promote sedimentation behind the fence.

Silt fences are preferable to straw bale barriers in many cases. Laboratory work at the Virginia Highway and Transportation Research Council has shown that silt fences can trap a much higher percentage of suspended sediments than can straw bales. While the failure rate of silt fences is lower than that of straw bale barriers, there are many instances where silt fences have been improperly installed. The following layout and installation guidance can improve performance and should be followed:

- Use principally in areas where sheet flow occurs.
- Don't use in streams, channels, or anywhere flow is concentrated. Don't use silt fences to divert flow.
- Don't use below slopes subject to creep, slumping, or landslides.
- Select filter fabric that retains 85% of soil by weight, based on sieve analysis, but that is not finer than an equivalent opening size of 70.
- Install along a level contour, so water does not pond more than 1.5 ft at any point along the silt fence.
- The maximum length of slope draining to any point along the silt fence should be 200 ft or less.
- The maximum slope perpendicular to the fence line should be 1:1.

- Provide sufficient room for runoff to pond behind the fence and to allow sediment removal equipment to pass between the silt fence and toes of slopes or other obstructions. About 1200 ft<sup>2</sup> of ponding area should be provided for every acre draining to the fence.
- Turn the ends of the filter fence uphill to prevent stormwater from flowing around the fence.
- Leave an undisturbed or stabilized area immediately down slope from the fence where feasible.
- Silt fences should remain in place until the disturbed area is permanently stabilized.

### *Design and Layout*

Selection of a filter fabric is based on soil conditions at the construction site (which affect the equivalent opening size (EOS) fabric specification) and characteristics of the support fence (which affect the choice of tensile strength). The designer should specify a filter fabric that retains the soil found on the construction site yet that it has openings large enough to permit drainage and prevent clogging. The following criteria is recommended for selection of the equivalent opening size:

1. If 50 percent or less of the soil, by weight, will pass the U.S. Standard Sieve No. 200, select the EOS to retain 85 % of the soil. The EOS should not be finer than EOS 70.
2. For all other soil types, the EOS should be no larger than the openings in the U.S. Standard Sieve No. 70 except where direct discharge to a stream, lake, or wetland will occur, then the EOS should be no larger than Standard Sieve No. 100.

To reduce the chance of clogging, it is preferable to specify a fabric with openings as large as allowed by the criteria. No fabric should be specified with an EOS smaller than U.S. Standard Sieve No. 100. If 85% or more of a soil, by weight, passes through the openings in a No. 200 sieve, filter fabric should not be used. Most of the particles in such a soil would not be retained if the EOS was too large and they would clog the fabric quickly if the EOS were small enough to capture the soil.

The fence should be supported by a plastic or wire mesh if the fabric selected does not have sufficient strength and bursting strength characteristics for the planned application (as recommended by the fabric manufacturer). Filter fabric material should contain ultraviolet inhibitors and stabilizers to provide a minimum of six months of expected usable construction life at a temperature range of 0 °F to 120 °F.

- Layout in accordance with attached figures.
- For slopes steeper than 2:1 (H:V) and that contain a high number of rocks or large dirt clods that tend to dislodge, it may be necessary to install additional protection immediately adjacent to the bottom of the slope, prior to installing silt fence. Additional protection may be a chain link fence or a cable fence.
- For slopes adjacent to sensitive receiving waters or Environmentally Sensitive Areas (ESAs), silt fence should be used in conjunction with erosion control BMPs.

**Materials**

- Silt fence fabric should be woven polypropylene with a minimum width of 36 in. and a minimum tensile strength of 100 lb force. The fabric should conform to the requirements in ASTM designation D4632 and should have an integral reinforcement layer. The reinforcement layer should be a polypropylene, or equivalent, net provided by the manufacturer. The permittivity of the fabric should be between  $0.1 \text{ sec}^{-1}$  and  $0.15 \text{ sec}^{-1}$  in conformance with the requirements in ASTM designation D4491.
- Wood stakes should be commercial quality lumber of the size and shape shown on the plans. Each stake should be free from decay, splits or cracks longer than the thickness of the stake or other defects that would weaken the stakes and cause the stakes to be structurally unsuitable.
- Staples used to fasten the fence fabric to the stakes should be not less than 1.75 in. long and should be fabricated from 15 gauge or heavier wire. The wire used to fasten the tops of the stakes together when joining two sections of fence should be 9 gauge or heavier wire. Galvanizing of the fastening wire will not be required.
- There are new products that may use prefabricated plastic holders for the silt fence and use bar reinforcement instead of wood stakes. If bar reinforcement is used in lieu of wood stakes, use number four or greater bar. Provide end protection for any exposed bar reinforcement.

**Installation Guidelines**

Silt fences are to be constructed on a level contour. Sufficient area should exist behind the fence for ponding to occur without flooding or overtopping the fence.

- A trench should be excavated approximately 6 in. wide and 6 in. deep along the line the proposed silt fence.
- Bottom of the silt fence should be keyed-in a minimum of 12 in.
- Posts should be spaced a maximum of 6 ft apart and driven securely into the ground a minimum of 18 in. or 12 in. below the bottom of the trench.
- When standard strength filter fabric is used, a plastic or wire mesh support fence should be fastened securely to the upslope side of posts using heavy-duty wire staples at least 1 in. long. The mesh should extend into the trench. When extra-strength filter fabric and closer post spacing are used, the mesh support fence may be eliminated. Filter fabric should be purchased in a long roll, and then cut to the length of the barrier. When joints are necessary, filter cloth should be spliced together only at a support post, with a minimum 6 in. overlap and both ends securely fastened to the post.
- The trench should be backfilled with compacted native material.
- Construct silt fences with a setback of at least 3 ft from the toe of a slope. Where a silt fence is determined to be not practicable due to specific site conditions, the silt fence may be constructed at the toe of the slope, but should be constructed as far from the toe of the slope as practicable. Silt fences close to the toe of the slope will be less effective and difficult to maintain.

- Construct the length of each reach so that the change in base elevation along the reach does not exceed 1/3 the height of the barrier; in no case should the reach exceed 500 ft.

## Costs

- Average annual cost for installation and maintenance (assumes 6 month useful life): \$7 per lineal foot (\$850 per drainage acre). Range of cost is \$3.50 - \$9.10 per lineal foot.

## Inspection and Maintenance

- Inspect BMPs prior to forecast rain, daily during extended rain events, after rain events, weekly during the rainy season, and at two-week intervals during the non-rainy season.
- Repair undercut silt fences.
- Repair or replace split, torn, slumping, or weathered fabric. The lifespan of silt fence fabric is generally 5 to 8 months.
- Silt fences that are damaged and become unsuitable for the intended purpose should be removed from the site of work, disposed of, and replaced with new silt fence barriers.
- Sediment that accumulates in the BMP must be periodically removed in order to maintain BMP effectiveness. Sediment should be removed when the sediment accumulation reaches one-third of the barrier height. Sediment removed during maintenance may be incorporated into earthwork on the site or disposed at an appropriate location.
- Silt fences should be left in place until the upstream area is permanently stabilized. Until then, the silt fence must be inspected and maintained.
- Holes, depressions, or other ground disturbance caused by the removal of the silt fences should be backfilled and repaired.

## References

Manual of Standards of Erosion and Sediment Control Measures, Association of Bay Area Governments, May 1995.

National Management Measures to Control Nonpoint Source Pollution from Urban Areas, United States Environmental Protection Agency, 2002.

Proposed Guidance Specifying Management Measures for Sources of Nonpoint Pollution in Coastal Waters, Work Group-Working Paper, USEPA, April 1992.

Sedimentation and Erosion Control Practices, and Inventory of Current Practices (Draft), UESPA, 1990.

Southeastern Wisconsin Regional Planning Commission (SWRPC). Costs of Urban Nonpoint Source Water Pollution Control Measures. Technical Report No. 31. Southeastern Wisconsin Regional Planning Commission. Waukesha, WI. 1991

Stormwater Quality Handbooks - Construction Site Best Management Practices (BMPs) Manual, State of California Department of Transportation (Caltrans), November 2000.

Stormwater Management Manual for The Puget Sound Basin, Washington State Department of Ecology, Public Review Draft, 1991.

U.S. Environmental Protection Agency (USEPA). Stormwater Management for Industrial Activities: Developing Pollution Prevention Plans and Best Management Practices. U.S. Environmental Protection Agency, Office of Water, Washington, DC, 1992.

Water Quality Management Plan for the Lake Tahoe Region, Volume II, Handbook of Management Practices, Tahoe Regional Planning Agency, November 1988.

# Silt Fence

SE-1

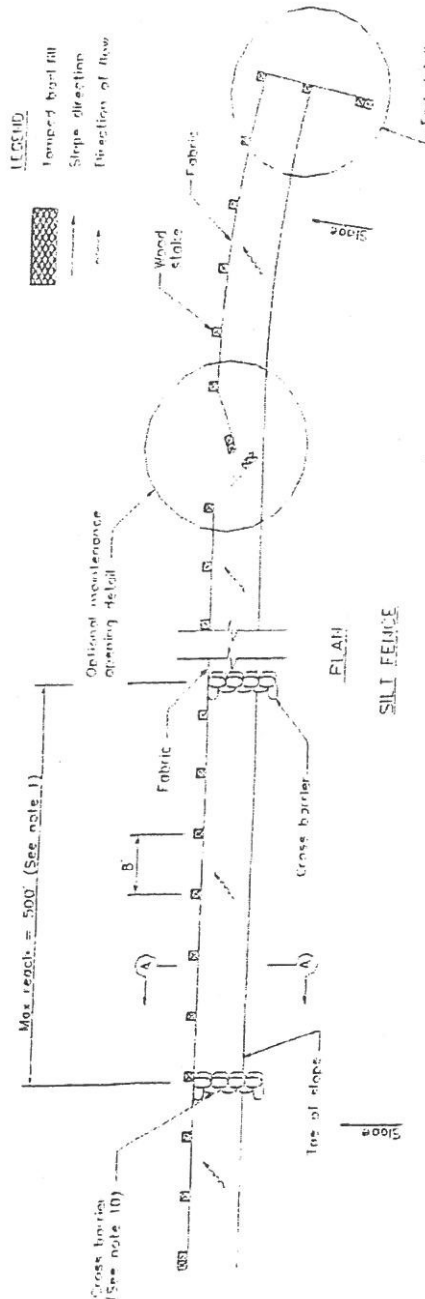

**NOTE**

1. Construct the length of each reach so that the change in base elevation along the reach does not exceed 1/2 the height of the linear barrier. In no case shall the reach length exceed 500.
2. The last 8'-0" of fence shall be turned up slope.
3. Stake dimensions are nominal.
4. Dimension in y direction to fill field condition.
5. Stakes shall be raised at 8'-0" maximum and shall be positioned on downstream side of fence.
6. Stakes to overlap and fence fabric to fold around each stake one full turn. Secure fabric to stake with 4 staples.
7. Stakes shall be driven tightly together to prevent potential flow-through of sediment at joint. The tops of the stakes shall be secured with wire.
8. For end stake, fence fabric shall be folded around two stakes one full turn and secured with 4 staples.
9. Minimum 4 staples per slope. Dimensions shown are typical.
10. Cross barriers shall be a minimum of 1/3 and a maximum of 1/2 the height of the linear barrier.
11. Maintenance openings shall be constructed in a manner to ensure sediment remains behind silt fence.
12. Joining sections shall not be placed at sump locations.
13. Sanding rows and layers shall be offset to eliminate gaps.

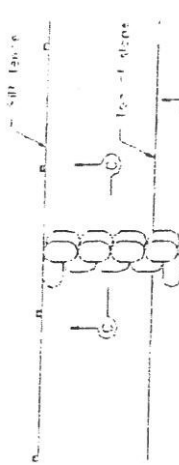

**CROSS BARRIER DETAIL**

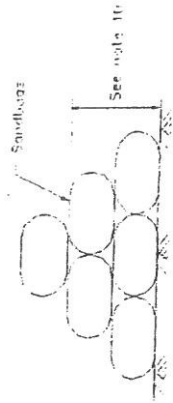

**SECTION C-C**

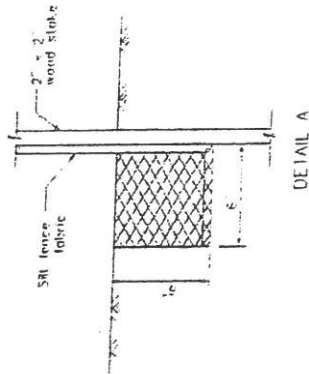
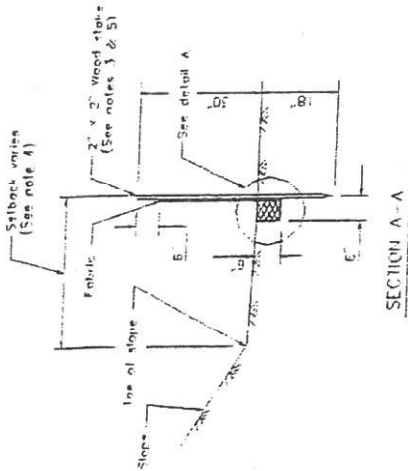
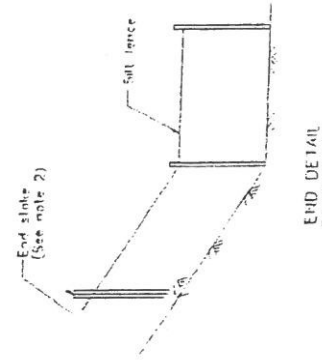
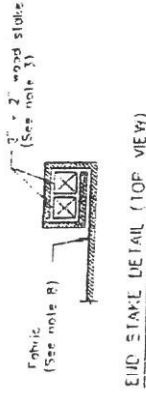
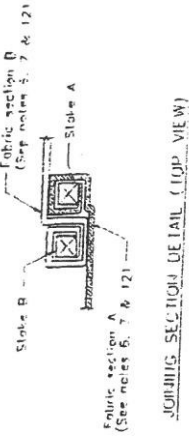
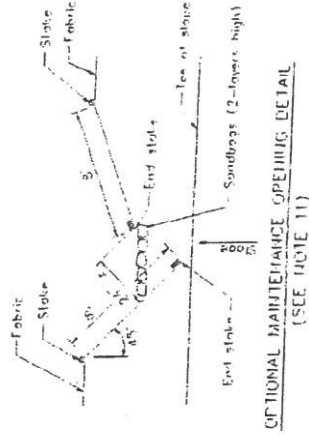
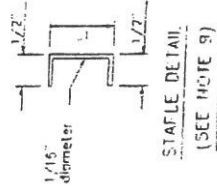
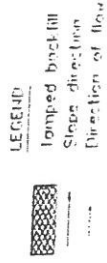

# Gravel Bag Berm

SE-6

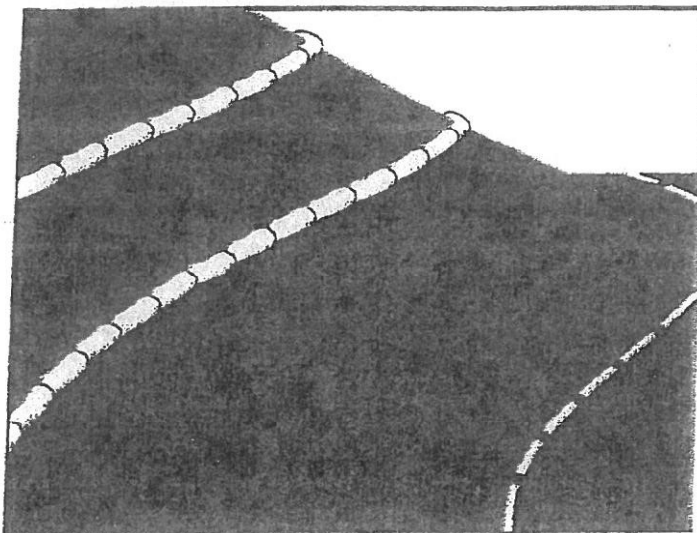

## Description and Purpose

A gravel bag berm is a series of gravel-filled bags placed on a level contour to intercept sheet flows. Gravel bags pond sheet flow runoff, allowing sediment to settle out, and release runoff slowly as sheet flows, preventing erosion.

## Suitable Applications

Gravel bag berms may be suitable:

- As a linear sediment control measure:
  - Below the toe of slopes and erodible slopes
  - As sediment traps at culvert/pipe outlets
  - Below other small cleared areas
  - Along the perimeter of a site
  - Down slope of exposed soil areas
  - Around temporary stockpiles and spoil areas
  - Parallel to a roadway to keep sediment off paved areas
  - Along streams and channels
- As linear erosion control measure:

## Objectives

EC	Erosion Control	<input checked="" type="checkbox"/>
SE	Sediment Control	<input checked="" type="checkbox"/>
TR	Tracking Control	
WE	Wind Erosion Control	
NS	Non-Stormwater Management Control	
WM	Waste Management and Materials Pollution Control	

## Legend:

- Primary Objective
- Secondary Objective

## Targeted Constituents

Sediment	<input checked="" type="checkbox"/>
Nutrients	
Trash	
Metals	
Bacteria	
Oil and Grease	
Organics	

## Potential Alternatives

- SE-1 Silt Fence
- SE-5 Fiber Roll
- SE-8 Sandbag Barrier
- SE-9 Straw Bale Barrier



- Along the face and at grade breaks of exposed and erodible slopes to shorten slope length and spread runoff as sheet flow
- At the top of slopes to divert runoff away from disturbed slopes
- As check dams across mildly sloped construction roads

**Limitations**

- Gravel berms may be difficult to remove.
- Removal problems limit their usefulness in landscaped areas.
- Gravel bag berm may not be appropriate for drainage areas greater than 5 acres.
- Runoff will pond upstream of the filter, possibly causing flooding if sufficient space does not exist.
- Degraded gravel bags may rupture when removed, spilling contents.
- Installation can be labor intensive.
- Berms may have limited durability for long-term projects.
- When used to detain concentrated flows, maintenance requirements increase.

**Implementation****General**

A gravel bag berm consists of a row of open graded gravel-filled bags placed on a level contour. When appropriately placed, a gravel bag berm intercepts and slows sheet flow runoff, causing temporary ponding. The temporary ponding provides quiescent conditions allowing sediment to settle. The open graded gravel in the bags is porous, which allows the ponded runoff to flow slowly through the bags, releasing the runoff as sheet flows. Gravel bag berms also interrupt the slope length and thereby reduce erosion by reducing the tendency of sheet flows to concentrate into rivulets, which erode rills, and ultimately gullies, into disturbed, sloped soils. Gravel bag berms are similar to sand bag barriers, but are more porous.

**Design and Layout**

- Locate gravel bag berms on level contours.
  - Slopes between 20:1 and 2:1 (H:V): Gravel bags should be placed at a maximum interval of 50 ft (a closer spacing is more effective), with the first row near the slope toe.
  - Slopes 2:1 (H:V) or steeper: Gravel bags should be placed at a maximum interval of 25 ft (a closer spacing is more effective), with the first row placed the slope toe.
- Turn the ends of the gravel bag barriers up slope to prevent runoff from going around the berm.
- Allow sufficient space up slope from the gravel bag berm to allow ponding, and to provide room for sediment storage.

- For installation near the toe of the slope, consider moving the gravel bag barriers away from the slope toe to facilitate cleaning. To prevent flows behind the barrier, bags can be placed perpendicular to a berm to serve as cross barriers.
- Drainage area should not exceed 5 acres.
- In Non-Traffic Areas:
  - Height = 18 in. maximum
  - Top width = 24 in. minimum for three or more layer construction
  - Top width = 12 in. minimum for one or two layer construction
  - Side slopes = 2:1 or flatter
- In Construction Traffic Areas:
  - Height = 12 in. maximum
  - Top width = 24 in. minimum for three or more layer construction.
  - Top width = 12 in. minimum for one or two layer construction.
  - Side slopes = 2:1 or flatter.
- Butt ends of bags tightly
- On multiple row, or multiple layer construction, overlap butt joints of adjacent row and row beneath.
- Use a pyramid approach when stacking bags.

### **Materials**

- **Bag Material:** Bags should be woven polypropylene, polyethylene or polyamide fabric or burlap, minimum unit weight of 4 ounces/yd<sup>2</sup>, Mullen burst strength exceeding 300 lb/in<sup>2</sup> in conformance with the requirements in ASTM designation D3786, and ultraviolet stability exceeding 70% in conformance with the requirements in ASTM designation D4355.
- **Bag Size:** Each gravel-filled bag should have a length of 18 in., width of 12 in., thickness of 3 in., and mass of approximately 33 lbs. Bag dimensions are nominal, and may vary based on locally available materials.
- **Fill Material:** Fill material should be 0.5 to 1 in. Class 2 aggregate base, clean and free from clay, organic matter, and other deleterious material, or other suitable open graded, non-cohesive, porous gravel.

### **Costs**

Gravel filter: Expensive, since off-site materials, hand construction, and demolition/removal are usually required. Material costs for gravel bags are average of \$2.50 per empty gravel bag. Gravel costs range from \$20- \$35 per yd<sup>3</sup>.

**Inspection and Maintenance**

- Inspect BMPs prior to forecast rain, daily during extended rain events, after rain events, weekly during the rainy season, and at two-week intervals during the non-rainy season.
- Gravel bags exposed to sunlight will need to be replaced every two to three months due to degrading of the bags.
- Reshape or replace gravel bags as needed.
- Repair washouts or other damage as needed.
- Sediment that accumulates in the BMP must be periodically removed in order to maintain BMP effectiveness. Sediment should be removed when the sediment accumulation reaches one-third of the barrier height. Sediment removed during maintenance may be incorporated into earthwork on the site or disposed at an appropriate location.
- Remove gravel bag berms when no longer needed. Remove sediment accumulation and clean, re-grade, and stabilize the area. Removed sediment should be incorporated in the project or disposed of.

**References**

Handbook of Steel Drainage and Highway Construction, American Iron and Steel Institute, 1983.

Stormwater Quality Handbooks - Construction Site Best Management Practices (BMPs) Manual, State of California Department of Transportation (Caltrans), November 2000.

Stormwater Pollution Plan Handbook, First Edition, State of California, Department of Transportation Division of New Technology, Materials and Research, October 1992.



## **APPENDIX "G"**

### **SCE IMPROVEMENT PLANS**

**FOR**

---

**PROJECT Nos. 7031, 85003, & 86004  
BID No. 2024-05  
11TH STREET FLASHING SIGNAL BEACON &  
ALLEY IMPROVEMENTS**

---

**CONSTRUCTION NOTES:**

- Unless otherwise specified on the working drawing which forms a part of the specification, the Contractor/Developer shall furnish the following items at no cost to the Edison Company.
- Southern California Edison Company has attempted to correctly show all existing utilities and structures in the vicinity of the work, but does not guarantee there are no other structures in the area. Failure of SCE to show all structures in their correct location will not be a basis for a claim for extra work, and the Contractor shall be responsible for all damages to structures whether shown or not.
- FOR GENERAL SPECIFICATIONS SEE UGS G 001.
  - CONDUIT:
    - Minimum cover in street or parkway is 30" below gutter grade, unless noted otherwise.
    - Minimum cover on private property is 30" below finished grade, unless noted otherwise.
    - Contractor is to furnish and install approved conduit to Edison specifications per UGS CD 100.1, 110 AND 120.
    - For the type of conduit for this job, see UGS CD 101.1.
    - Install all risers per UGS CD 160, 161, 162 and 170.
    - Cap all mainline conduits per UGS CD 148 and service conduits per UGS CD 150.
    - Install blank conduit plugs in all conduits terminating into vaults, manholes, P.M.H.'s, SDE's & all cap locations, per UGS CD 180.1 & UGS CD 180.2.
    - Install pull rope in all conduit runs. Pull rope to be at least 3/8" polypropylene rope, braided or twisted. For specifications, approved mules, and suppliers, see UGS G 040.
    - All conduit must be manholed with the approved mandrel UGS CD 197.
  - CONDUIT RADIUS REQUIREMENTS:
    - The minimum radius for bends are:
      - 36" for conduits 3" in diameter or smaller
      - 48" for conduits 4" and 5" in diameter
      - 60" for 6" diameter conduit
    - The minimum radius for all sweeps of all mainline conduits is 12'-6" (unless noted otherwise).
  - EXCAVATION AND BACKFILL:
    - Work area shall be cleared and rough graded to within four inches of final grade prior to installation of Edison conduit or structures.
    - All excavations shall be in accordance with the California State Construction Safety Orders (when applicable), Edison specifications, and all governing local ordinances.
    - Each trench to be a uniform depth below final grade prior to installation of Edison conduit or structures.
    - Backfill shall be provided by the Contractor for all excavations and shall include crushed rock, concrete, and/or imported backfill, when required.
    - Backfill with a MINIMUM of one sack per yard sand cement slurry around and over vaults and manholes per UGS G 030, section 6.4 and around P.M.H.'s within one foot of finished grade, per UGS SS 590.1.
    - Backfill, per Edison specifications, shall immediately follow conduit or substructure installation. At no time shall conduit be left exposed over 24 hours.
    - No rocks are allowed within 12 inches of direct-buried cables or any conduit without concrete encasement. Native backfill capable of passing through a one-half inch mesh screen shall be considered to be "rock free". If existing backfill does not pass through a 1/2" screen, place imported sand 3" below and 12" above Edison cables. After this point, no rocks larger than 12" diameter are permitted.
    - All backfill shall be compacted to meet or exceed local ordinances or other requirements. It shall be placed in a manner that will not damage the conduit or substructure or allow future subsidence of the trench or structures.
  - PAVING:
    - Repeating, where required, shall be placed in such a manner that interference with traffic, including pedestrian traffic, will be kept to a minimum. The Contractor shall establish a program of repeating acceptable to the Municipality, County, or other authority having jurisdiction and which is acceptable to Edison.
  - STRUCTURES:
    - All substructures shall be constructed or installed to Edison specifications.
    - Install protection barriers per UGS MS 830 when required in areas exposed to traffic, per Edison Inspector.
    - All conduit lines and concrete floor substructures shall be water tight.
    - All grounding materials shall be furnished and installed by the Contractor.
  - RETAINING WALLS:
    - When required, retaining walls shall be provided by the Developer. Walls are required wherever grade rises more than 18 inches above the structure or 24" above the pad surface, or at a distance of 5 feet from the same, or in areas subject to erosion. Design and installation must comply with local building ordinances. Refer to Edison Inspector for typical space requirements.
  - PERMITS:
    - All permits necessary for excavation shall be provided by the Contractor/Developer.
  - ACCESS:
    - Heavy truck access shall be maintained to equipment locations. Structures must be clear of all appurtenances that would obstruct the loading or unloading of equipment.
  - SERVICES:
    - Meters and services shall comply with Edison Electrical Services Requirements.
    - Wiring must be in accordance with applicable local ordinances and approved by local Inspection Authorities.
  - LOCATION:
    - The location of excavations and structures for Edison shall be as shown on the working drawing. No deviation from the planned locations will be permitted unless approved by the Edison Inspector. See UGS G 001, section 2.2.
    - Actual location of obstructions, storm drains, and/or other foreign utilities to be the responsibility of the Contractor. See UGS G 001, section 2.3.
  - CONTRACTOR IS TO VERIFY LOCATION AND WIDTHS OF ALL SIDEWALKS AND DRIVEWAYS PRIOR TO STREET LIGHT INSTALLATION. See UGS CD 175.1, UGS CD 175.2 and UGS CD 175.3.
  - SURVEY:
    - Surveying of street improvements, property corners, lot lines, finished grade, etc., necessary for the installation of underground facilities must be completed and markers or stakes placed prior to the start of the installation. In addition, Developer shall maintain the markers during the installation and inspection by Edison. Grade and property line stakes must show any offset measurements.
  - COORDINATION AND SUPERVISION:
    - The Developer shall provide supervision over and coordination among the various contractors working within the development in order to prevent damage to Edison facilities. He is responsible for the cost of repairs, replacement, relocation, or other corrections to Edison facilities made necessary by his failure to provide supervision or to otherwise comply with these specifications.
  - TELEPHONE AND OTHER UTILITY REQUIREMENTS:
    - The drawing prepared for this job may also cover the facilities to be installed for the telephone company and/or other utility. Any questions concerning details of their installation should be referred to the company concerned.
  - OWNER'S DEVELOPER:
    - Developer is to deed to the Edison Company all structures shown hereon except those shown as customer owned.
  - WARRANTY:
    - Applicants expressly represent and warrant that all work performed and all material used in meeting Applicants' obligations herein are free from defects in workmanship and are in conformity with Southern California Edison Company's requirements. This warranty shall commence upon receipt by Applicants of Company's final acceptance and shall expire one year from that date. Applicants agree to promptly correct to the Company's satisfaction and that of any governmental agency having jurisdiction and at Applicant's expense any breach of this warranty which may become apparent through inspection or operation of underground electric system by Company during this warranty period.
  - INSPECTION:
    - Inspection is required during the construction period. A 48 hour advance notice of intent to start construction is required from the contractor to the Southern California Edison Company. Standards of Edison construction requirements are available upon request.

Duct and Structure Inspector: CHRIS URIBE Phone: 840-210-2686  
 Cabling Construction Coordinator: BRYCE MUNDAY Phone: 626-658-6598

D05: Rev. 07/21/16

**LEGEND OF CONDUIT SYMBOLS (CONVENTIONAL U. G.)**

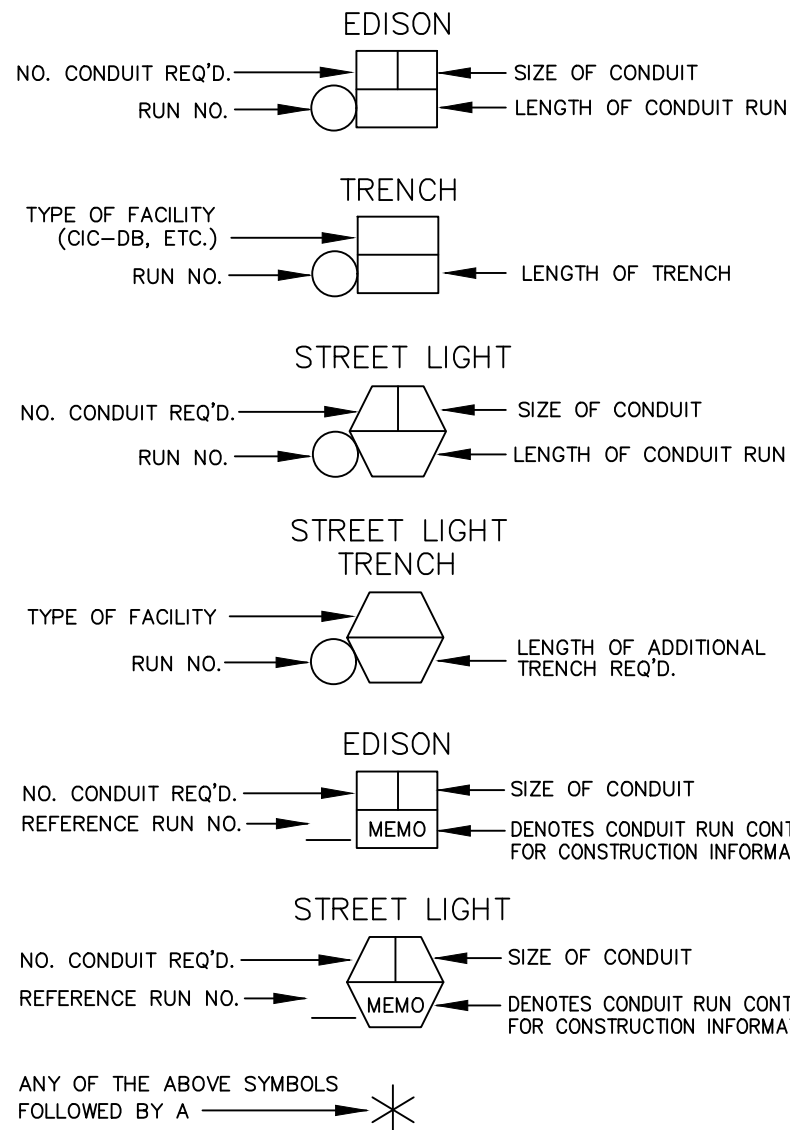

**DENOTES THE FOLLOWING:**

- DB CONDUIT WITHOUT ENCASUREMENT IS ACCEPTABLE FOR PORTIONS OF TRENCH WITH ONLY ONE OR TWO CONDUITS
- SEMI-ENCASUREMENT IS REQUIRED FOR PORTIONS OF TRENCH WITH ONLY THREE OR FOUR CONDUITS
- FULL ENCASUREMENT IS REQUIRED FOR MORE THAN FOUR CONDUITS

D18: Rev. 5/08/2006

**LEGEND CODE DEFINITIONS**

- CI - CUSTOMER CONTRACTOR INSTALLED; MATERIALS FURNISHED AND INSTALLED BY APPLICANT AT EDISON'S EXPENSE AND ARE DEEDED TO EDISON. (EXCEPTION: STREET LIGHT ELECTRICIERS WILL BE INSTALLED BY EDISON'S CONTRACTOR.)
- CO - CUSTOMER CONTRACTOR OWNED; MATERIALS FURNISHED, INSTALLED, OWNED, AND MAINTAINED BY APPLICANT.
- CF - CUSTOMER CONTRACTOR FURNISHED; MATERIALS FURNISHED AND INSTALLED BY APPLICANT AT APPLICANT'S EXPENSE, THAT MAY BE DEEDED TO EDISON.
- IN - INSTALL; MATERIALS FURNISHED AND INSTALLED BY APPLICANT IF APPLICANT INSTALLED PROJECT OR BY EDISON IF EDISON INSTALLED PROJECT. (EXCEPTION: FOR AN APPLICANT INSTALLED LINE EXTENSION, STATION NOS.)
- HAVING AN asterisk ADJACENT TO AN "N" LEGEND CODE REPRESENTS MATERIALS TO BE PROVIDED BY APPLICANT AND INSTALLED BY EDISON IN ALL CASES. REFER TO D99 8258. PROJECT MATERIAL LIST BY ASSEMBLY WITHIN A STATION.
- MI - MEMO INSTALL; SAME AS IN-INSTALL.
- MR - MEMO REMOVE; MATERIALS REMOVED BY EDISON.
- RM - MEMO REMOVED; MATERIALS REMOVED BY EDISON.
- SI - SHOOFY IN; MATERIALS FURNISHED AND INSTALLED BY EDISON FOR TEMPORARY CONSTRUCTION.
- SR - SHOOFY REMOVE; MATERIALS REMOVED BY EDISON FOR TEMPORARY CONSTRUCTION.
- TR - TRANSFER; EDISON LABOR REQUIRED TO TRANSFER EXISTING FACILITIES.

D31: Rev. 11/85

**PANEL CLEARANCE UNDERGROUND SERVICE CONNECTIONS 0-600 VOLTS SEE ESR 3-16**

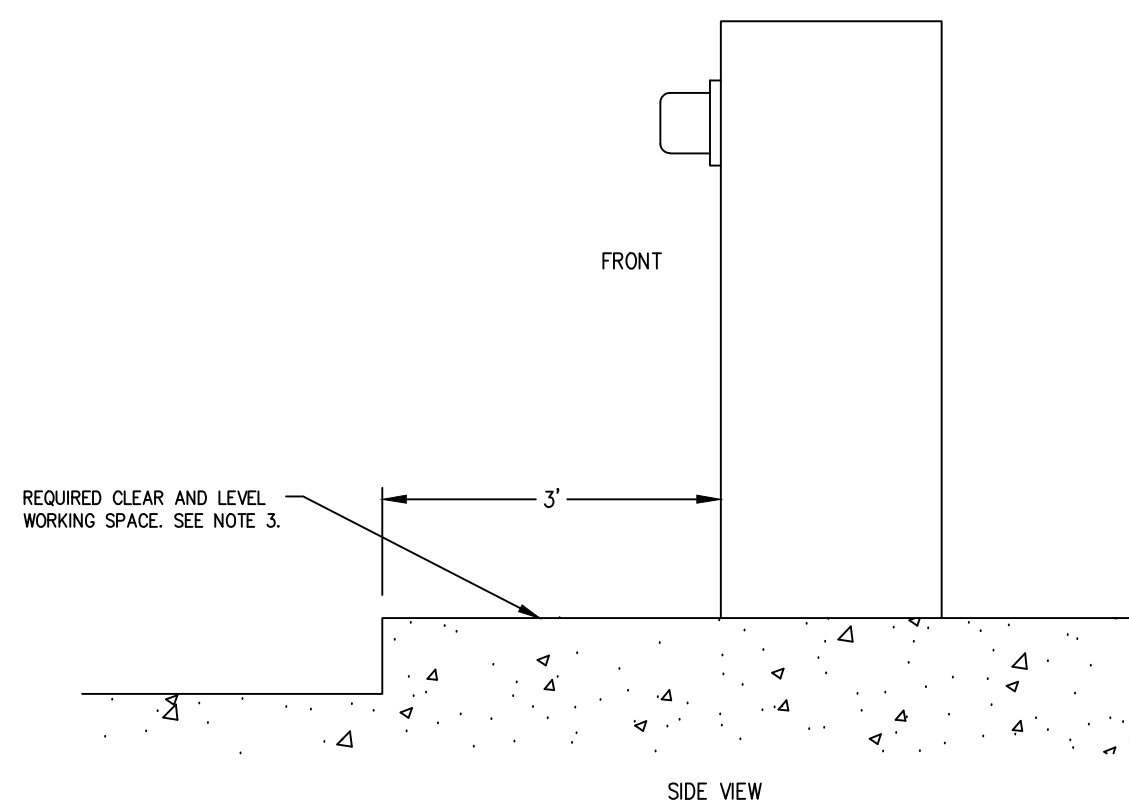

**NOTES:**

- A MINIMUM OF THREE (3) FEET OF CLEAR, LEVEL WORK SPACE IS REQUIRED IN FRONT OF ALL TERMINATION, METERING, AND SERVICE EQUIPMENT.
- SEE ESR-5 FOR METER-MOUNTING HEIGHT REQUIREMENTS. METER MOUNTING HEIGHT WILL BE MEASURED FROM THE STANDING AND WORKING SPACE TO THE CENTERLINE OF THE METERS.
- WHEN SERVICE EQUIPMENT IS INSTALLED ON AN ELEVATED PORTION OF THE FLOOR/GROUND, OR HOUSEKEEPING PAD, THE PAD SHALL BE FILLED WITH AND EXTEND A MINIMUM OF THREE (3) FEET. THIS IS MEASURED FROM THE FRONT OF THE SERVICE EQUIPMENT OR THE OUTER DOOR(S) OF THE SWITCHBOARD NEAR OR ENCLOSURE WHEN INSTALLED. IN NO CASE SHALL THE MAXIMUM METER HEIGHT OF SIX (6) FEET THREE (3) INCHES BE EXCEEDED.
- TO MAINTAIN A SAFE, CLEAR, AND LEVEL WORKING AREA IN FRONT OF NEW OR EXISTING METER AND SERVICE EQUIPMENT, A CONCRETE SLAB OR OTHER SUITABLE PERMANENT HARD SURFACE, ACCEPTABLE TO THE COMPANY, MUST BE USED.
- FOR SWITCHBOARDS ABOVE 600V, FIVE-FOOT MINIMUM CLEAR AND LEVEL STANDING AND WORKING SPACE IS REQUIRED IN THE FRONT, REAR, AND SIDE OF ANY SECTION WHERE SUCH PART SUPPORTS OR PROVIDES ACCESS TO METERING, TESTING EQUIPMENT, OR SERVICE CABLE TERMINATION SECTIONS.

**16.12 PROTECTIVE BARRIERS FOR SERVICE EQUIPMENT**

BARRIER POSTS ARE USED TO PROTECT THE METER AND SERVICE EQUIPMENT, AS WELL AS PERSONNEL, FROM VEHICULAR CONTACT, AND TO PROHIBIT ENCROACHMENT INTO THE WORKING SPACE. (FOR EXAMPLE: LOADING ZONES, DRIVEWAYS, EXPOSED AREAS, OFF STREET PARKING, AND SO ON.) THE CUSTOMER SHALL PROVIDE AND INSTALL "NON-REMOVABLE" BARRIERS TO PROVIDE THE PROPER SAFE WORKING CLEARANCES WHERE THE WORKSPACE IS EXPOSED TO VEHICULAR OR OTHER HAZARDOUS CONDITIONS. METERS WILL NOT BE SET UNTIL THE BARRIERS HAVE BEEN INSTALLED.

D99: 10/26/20

**TYPICAL MOBILE HOME OR RESIDENTIAL SERVICE AND METER POST MAX. 200A-120/240 V SEE ESR 3 FIG. 3-25**

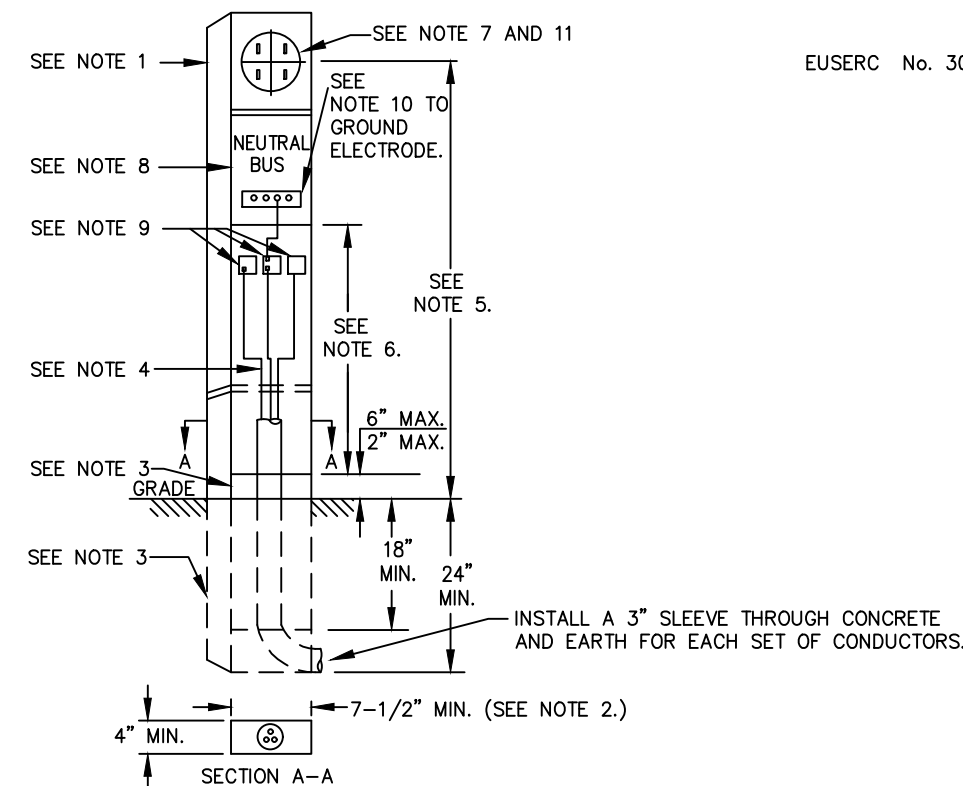

EUSRC No. 307

**NOTES:**

- THIS TYPE POST SHALL HAVE A MINIMUM RATING OF 100 A. POSTS SHALL BE INSTALLED IN SUCH A MANNER THAT THEY WILL REMAIN PLUMB AND RIGID. CONSTRUCTION, MATERIAL, AND CORROSION-RESISTANT FINISH SHALL BE APPROVED BY A RECOGNIZED TEST LABORATORY.
- MINIMUM WIDTH OF ACCESS OPENING SHALL BE 7-1/2 INCHES.
- THE MINIMUM DEPTH OF THE POST IN THE GROUND SHALL BE 24 INCHES WITH OPENINGS AT THE BASE TO PERMIT THE SERVICE LATERAL CONDUIT OR CONDUCTORS TO SWEEP INTO THE POST FROM THE FRONT (METER SIDE). A FIXED PANEL SHALL EXTEND TWO INCHES MINIMUM TO SIX INCHES MAXIMUM ABOVE GRADE, AND 18 INCHES MINIMUM BELOW GRADE.
- ADEQUATE VENTILATION SHALL BE PROVIDED TO INHIBIT THE CONDENSATION OF MOISTURE WITHIN THE ENCLOSURE.
- THE MINIMUM METER HEIGHT SHALL BE 36 INCHES ABOVE THE GRADE LINE WHEN THE METER IS ENCLOSED, OR 48 INCHES WHEN EXPOSED.
- THE SERVICE CABLE PULL AND TERMINATING SECTION SHALL BE ACCESSIBLE FROM EITHER THE FRONT OR REAR OF THE POST BY REMOVING AN EIGHT-INCH MINIMUM WIDTH SEALABLE PANEL (OR PANELS). THE REMOVABLE PANEL (OR PANELS) SHALL EXTEND FROM THE TOP OF THE FIXED PANEL. (SEE NOTE 3) AND WHEN REMOVED, ALLOW FULL ACCESS TO THE TERMINATING LUGS. THE SERVICE CABLE PULL AND TERMINATING SECTION SPACE SHALL BE RESTRICTED TO COMPANY USE.
- METER PANELS SHALL BE REMOVABLE, BUT SHALL BE NON-REMOVABLE WHEN METER IS IN PLACE. IF THE METER IS ENCLOSED, THE ENCLOSING COVER SHALL BE HINGED AND SELF-SUPPORTING, EQUIPPED WITH A CLEAR READING WINDOW, AND MUST BE REMOVABLE FOR METER TESTING OR INSPECTION.
- THE SERVICE MAIN DISCONNECT AND POWER OUTLET SECTION SHALL HAVE BARRIERS INSTALLED TO PREVENT ACCESS TO THE SERVICE CABLE PULL AND TERMINATION SECTION AND TO UNTERMINATED CONDUCTORS WHICH CONNECT TO THE SOCKET.
- THE SERVICE TERMINATING LUGS SHALL BE TWIN #2 TO 350 KOMIL ALUMINUM-BODIED PRESSURE-TYPE, LUG HEIGHT, MEASURED TO THE BOTTOM OF TERMINATING LUG FROM THE TOP OF THE FIXED PANEL, SHALL BE 18 INCHES MINIMUM AND 48 INCHES MAXIMUM. THE SPACE BETWEEN TERMINATING LUGS FROM LUGS TO SIDES OF POST, FROM LUGS TO ANY GROUNDED SURFACE, OR FROM LUGS TO PANEL ABOVE, SHALL BE 1-1/2 INCHES MINIMUM. RIGID INSULATED BARRIERS ARE REQUIRED AND SHALL PROJECT 1/4-INCH MINIMUM BEYOND ANY ENERGIZED PARTS WHEN THIS SPACE IS REDUCED. TERMINATING LUGS MAY BE POSITIONED OTHER IN LINE OR STAGGERED AND ACCESS SHALL BE UNOBSTRUCTED WHEN ALL SERVICE CONDUCTORS ARE IN PLACE.
- A CUSTOMER-ACCESSIBLE EQUIPMENT GROUNDING LUG SHALL BE PROVIDED.
- THE METER SOCKET BASE SHALL BE FABRICATED WITH COMPONENTS TESTED BY A RECOGNIZED TEST LABORATORY AND SHALL BE PROVIDED WITH A SEALING RING; THE METER SOCKET SHALL BE MOUNTED ON A SUPPORT WHICH IS ATTACHED TO THE METER PANEL. SOCKETS SHALL BE FACTORY-WIRED WITH CONDUCTORS IN A SEPARATE OR BARRIERED RACEWAY FROM THE SERVICE TERMINATING LUGS TO THE METER SOCKET. THESE CONDUCTORS SHALL BE INACCESSIBLE FROM THE MAIN DISCONNECT AND POWER OUTLET SECTION. THE CONDUCTOR WHICH EXTENDS TO THE METER SOCKET SHALL BE CONNECTED AT THE SERVICE TERMINATING LUGS, INDEPENDENTLY OF THE CONNECTION FOR THE SERVICE LATERAL CONDUCTORS.
- AN UNOBSTRUCTED WORK SPACE OF 36 INCHES MINIMUM ENTIRELY ON THE PROPERTY OF THE CUSTOMER SHALL BE MAINTAINED IN FRONT OF METERING AND TERMINATING SECTIONS.
- THE GROUNDING ELECTRODE CONDUCTOR MAY BE RUN THROUGH THE TERMINATING ENCLOSURE.
- THE SERVICE EQUIPMENT (SERVICE AND METER POST), ALL WIRING, AND EQUIPMENT FROM THE METER POST TO THE CUSTOMER'S STRUCTURE SHALL BE PROVIDED BY THE OWNER/DEVELOPER.
- CONSULT THE LOCAL COMPANY SERVICE PLANNING OFFICE BEFORE LOCATING THE SERVICE EQUIPMENT. WHEN SERVICE EQUIPMENT IS IMPROPERLY LOCATED DUE TO THE COMPANY NOT BEING CONTACTED PRIOR TO THE INSTALLATION, THE OWNER/DEVELOPER IS RESPONSIBLE FOR ALL MODIFICATIONS.

D125: Rev. 10/26/20

**THREE, FOUR, FIVE, OR SIX-INCH FIBERGLASS RISER BENDS SEE UGS CD 166**

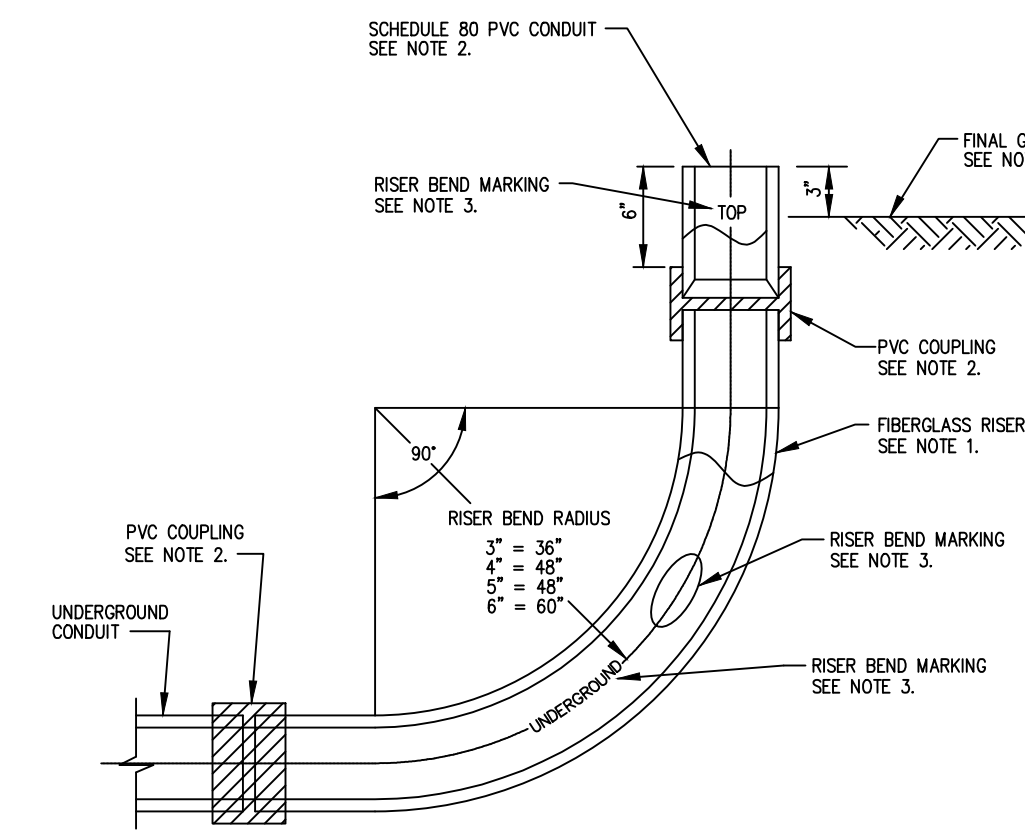

**NOTES:**

- THE RISER BEND IS AVAILABLE IN THREE, FOUR, FIVE OR SIX-INCH SIZES. THE MAIN BODY OF THE BEND IS MANUFACTURED FROM FIBERGLASS MATERIAL AND IS MEDIUM GRAY IN COLOR.
- THE TOP AND BOTTOM OF RISER IS FURNISHED WITH PVC COUPLINGS PERMANENTLY EPOXY BONDED TO THE FIBERGLASS BEND.
- A SCHEDULE 80 PVC SIX-INCH LONG STUB-OUT IS SOLVENT WELDED INTO THE TOP PVC COUPLING.
- THE TOP SCHEDULE 80 PVC STUB-OUT OF BEND IS STENCILED "TOP" AND BOTTOM OF BEND IS STENCILED "UNDERGROUND."
- MANUFACTURER'S NAME, SIZE, AND DATE (MONTH AND YEAR) WILL BE STENCILED ON THE CENTER OF THE RISER BEND.
- THE TOP SCHEDULE 80 PVC STUB-OUT WILL BE PLACED THREE INCHES ABOVE FINAL GRADE. NO PORTION OF THE FIBERGLASS MATERIAL OF THE BEND WILL BE EXPOSED ABOVE THE FINAL GRADE.
- THE APPROVED MANUFACTURERS AND SUPPLIERS ARE:
  - MANUFACTURERS: FRE CONDUIT, SMITH PRODUCT COMPANY, AND CHAMPION FIBERGLASS, INC.
  - SUPPLIERS:
    - ONE TIME UTILITY, 501 GARFIELD STREET, SANTA ANA, CA 92701
    - CAL-DUCT, INC., 2522 LEE AVENUE, SOUTH EL MONTE, CA 91733
    - SAF-T-CD SUPPLY, INC., 1300 E. NORMANWAY PLACE, SANTA ANA, CA 92705

D39: Rev. 10/26/20

**POLE RISER BEND STANDARD LOCATION SEE UGS CD 160**

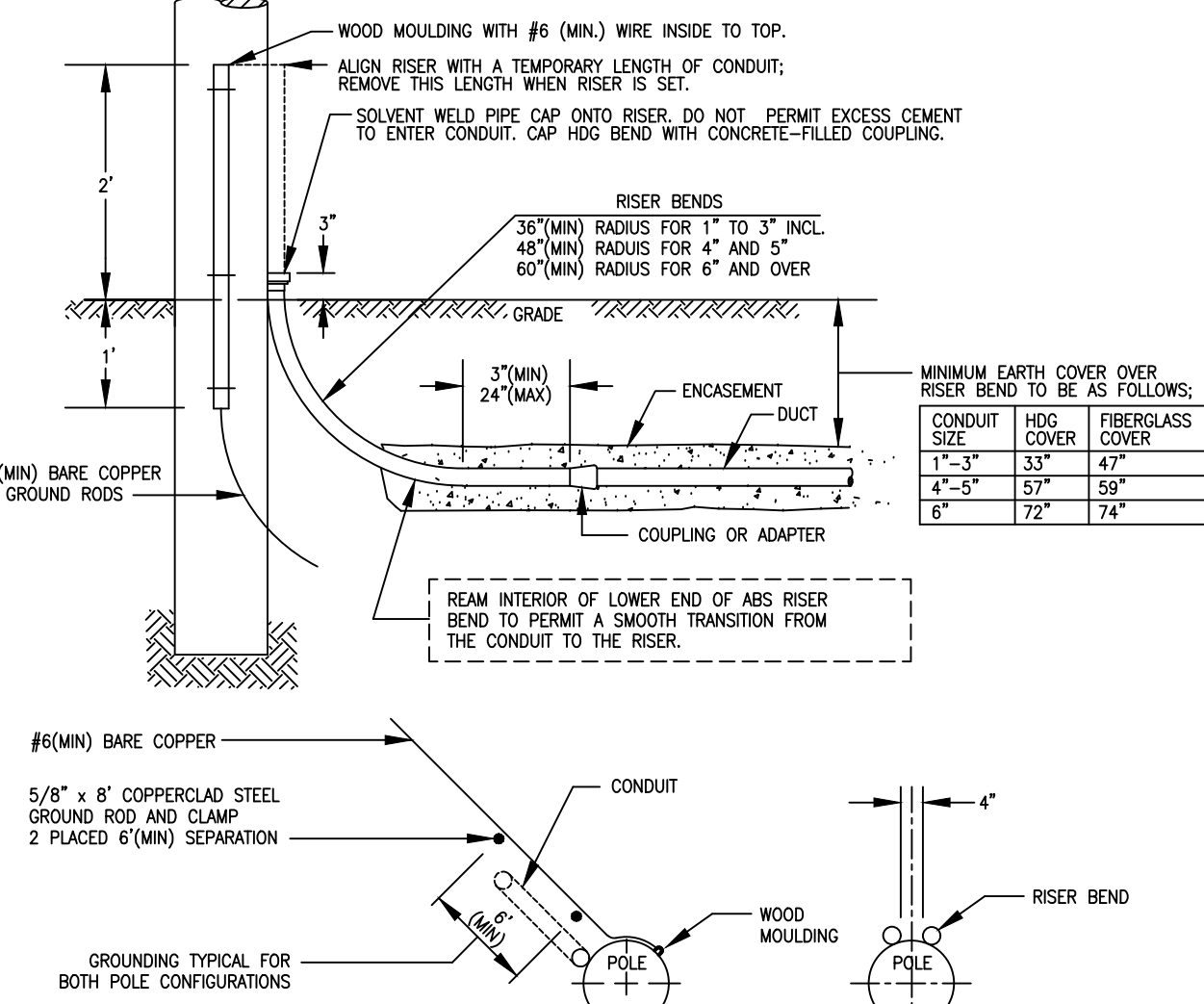

**1. APPROVED RISER BENDS ARE SHOWN ON FOLLOWING TABLE:**

MATERIAL	1"	1-1/2"	2"	2-1/2"	3"	4"	5"	6"
FIBERGLASS	-	-	-	-	X	X	X	X
HDG	X	X	X	X	X	X	X	X

NOTE: 6" HDG OR FIBERGLASS RISER BEND SHALL BE USED WHEN SPECIFIED ON THE WORKING DRAWING. SEE UGS AC 702 FOR GROUNDING HDG RISER BENDS.

- THE TOP AND BOTTOM OF 3", 4", 5" OR 6" FIBERGLASS BENDS ARE FURNISHED WITH PERMANENTLY ATTACHED PVC COUPLINGS. ALSO INCLUDED IS A 6" LONG 3", 4", 5" OR 6" SCHEDULE 80 PVC STUB-OUT, SOLVENT WELDED INTO THE TOP COUPLING. SEE UGS CD 166 FOR FIBERGLASS RISER BEND MATERIAL INFORMATION AND SUPPLIERS.
- TWO GROUND RODS ARE REQUIRED AT ALL PRIMARY RISER POLES. DRIVE RODS IN TRENCH BOTTOM WITH 6" MINIMUM SEPARATION IN UNDISTURBED EARTH. LEAVE THE ROD TOPS 3" ABOVE THE TRENCH BOTTOM AND ATTACH CONTINUOUS GROUND WIRE WITH CLAMPS. EXTEND WIRE TO INDICATED LOCATION ON POLE AND STUB UP 2" ABOVE GRADE IN WOOD MOULDING. ALL GROUNDING MATERIALS FURNISHED BY CONTRACTORS. SEE UGS AC 703 FOR APPROVED GROUNDING MATERIALS.
- ENCASUREMENT REQUIRED ONLY WHEN CALLED OUT ON WORKING DRAWING.
- PVC RISERS MAY BE SUBSTITUTED FOR FIBERGLASS FOR STRAIGHT RUNS OF 150' OR LESS IN CONDUIT SIZES 4" AND UNDER.

D78: REV. 02/14/11

**TYPICAL HANDHOLE INSTALLATION SEE UGS HP 205**

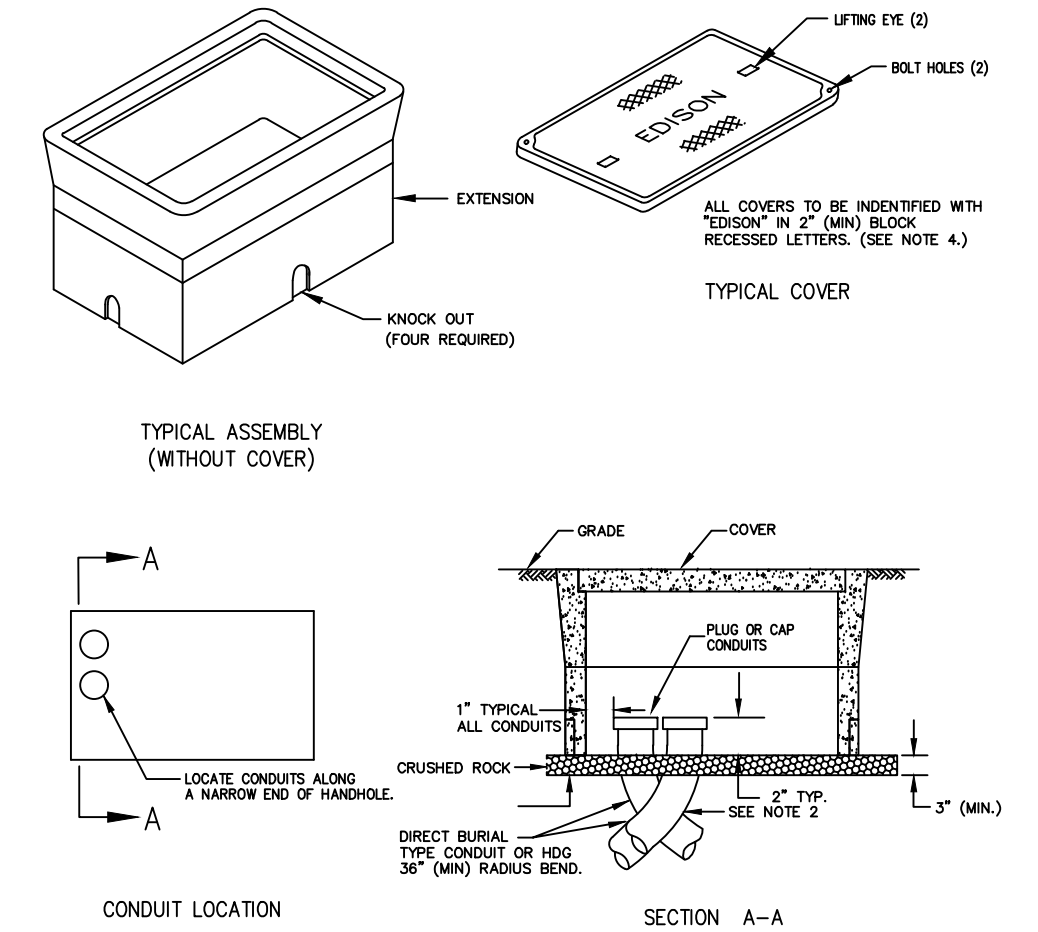

**NOTES:**

- SEE UGS HP 200 FOR DIMENSIONS OF VARIOUS SIZE HANDHOLES AVAILABLE.
- RADIUS ANGLE MAY BE REDUCED TO LESS THAN 90° PROVIDING THE PROJECTED CENTER LINE OF THE CONDUIT CLEARS HANDHOLE OPENING.
- TWO HOLD DOWN DEVICES TO BE SUPPLIED WITH EACH HANDHOLE.
- COVER SHALL BE IDENTIFIED WITH "EDISON" IN MINIMUM 2-INCH LETTERS OR LABELS PERMANENTLY SECURED TO THE LID.
- FOR MAINTENANCE ON 10-1/2" X 17" CONCRETE HANDHOLES USE SWINGBOLT WITH SAP 10204721.

D75: REV. 03/18/19

**TYPICAL CONDUIT BANK SECTION SEE UGS CD 120**

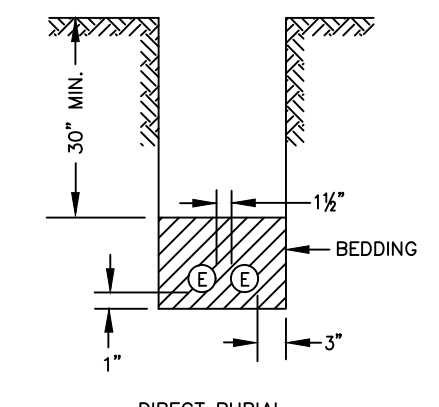

SIMILAR CONSTRUCTION FOR FEWER CONDUIT 2 CONDUITS MAX.

D81: Rev. 09/23/09

**CONDUIT RADIUS REQUIREMENTS:**

- The minimum radius for bends are:
  - 36" for conduits 3" in diameter or smaller
  - 48" for conduits 4" and 5" in diameter
  - 60" for 6" diameter conduit
- The minimum radius for sweeps are:
  - 36" for conduits 3" in diameter or smaller
  - 48" for conduits 4" in diameter and larger, unless otherwise noted.

**WARNING**

THE EXCAVATOR MUST TAKE ALL STEPS NECESSARY TO AVOID CONTACT WITH UNDERGROUND FACILITIES WHICH MAY RESULT IN INJURY TO PERSONS OR DAMAGE TO FACILITIES IN THE AREA. THE INDICATED LOCATIONS OF EDISON UNDERGROUND FACILITIES, AS PROVIDED, ARE BELIEVED TO BE ACCURATE. HOWEVER, THE FINAL DETERMINATION OF EXACT LOCATIONS AND THE COST OF REPAIR TO DAMAGED FACILITIES IS THE RESPONSIBILITY OF THE EXCAVATOR.

**NOTE:**

ALL ELECTRICAL DUCTS AND STRUCTURES WILL CONFORM TO GENERAL ORDER #128 (RULES FOR CONSTRUCTION OF UNDERGROUND ELECTRICAL SUPPLY AND COMMUNICATION PRESCRIBED BY THE PUBLIC UTILITIES COMMISSION OF THE STATE OF CALIFORNIA, JANUARY 2006).

**UNDERGROUND SERVICE ALERT**  
 Contact USA  
 Dial 811 or 800-422-4133  
 www.digalert.org/contact

For Underground Locating  
 Two Working Days Before You Dig

D16: Rev. 05/28/20

**FINAL DESIGN APPROVED FOR CONSTRUCTION**

DISTRICT 34 - ONTARIO	PROJ. MGR. JOHNSON, TIMOTHY 661-726-5691	PLANNER JOHNSON, TIMOTHY 661-388-3076	DESIGNER PONCE, NANCY PATRICIA
PROJECT NO. 2611830	SERVICE REQUEST 3499739	PRODUCT-1 2136038-LINE EXTENSION	ASSOC. DESIGN
CIRCUIT / VOLTAGE MEAGAN 12kV	GPS	PRODUCT-2	ASSOC. DESIGN
SUB / PG NO. UPLAND SUB	CIRCUIT CODE	PRODUCT-3	ASSOC. DESIGN
INVENTORY MAP	J.P.A. NO.	PROPOSED CONSTRUCTION (LOCATION) LINE EXTENSION 1100 11TH ST UPLAND CA 91786	
6-13-23	T. JOHNSON	N. PONCE	
TYPE	DATE	APPROVED BY	CHECKED BY
Southern California Edison Company		SHEET 1 of 2	DESIGN/DRWG NO. 1629402_1.01

CITY OF UPLAND  
LINE EXTENSION

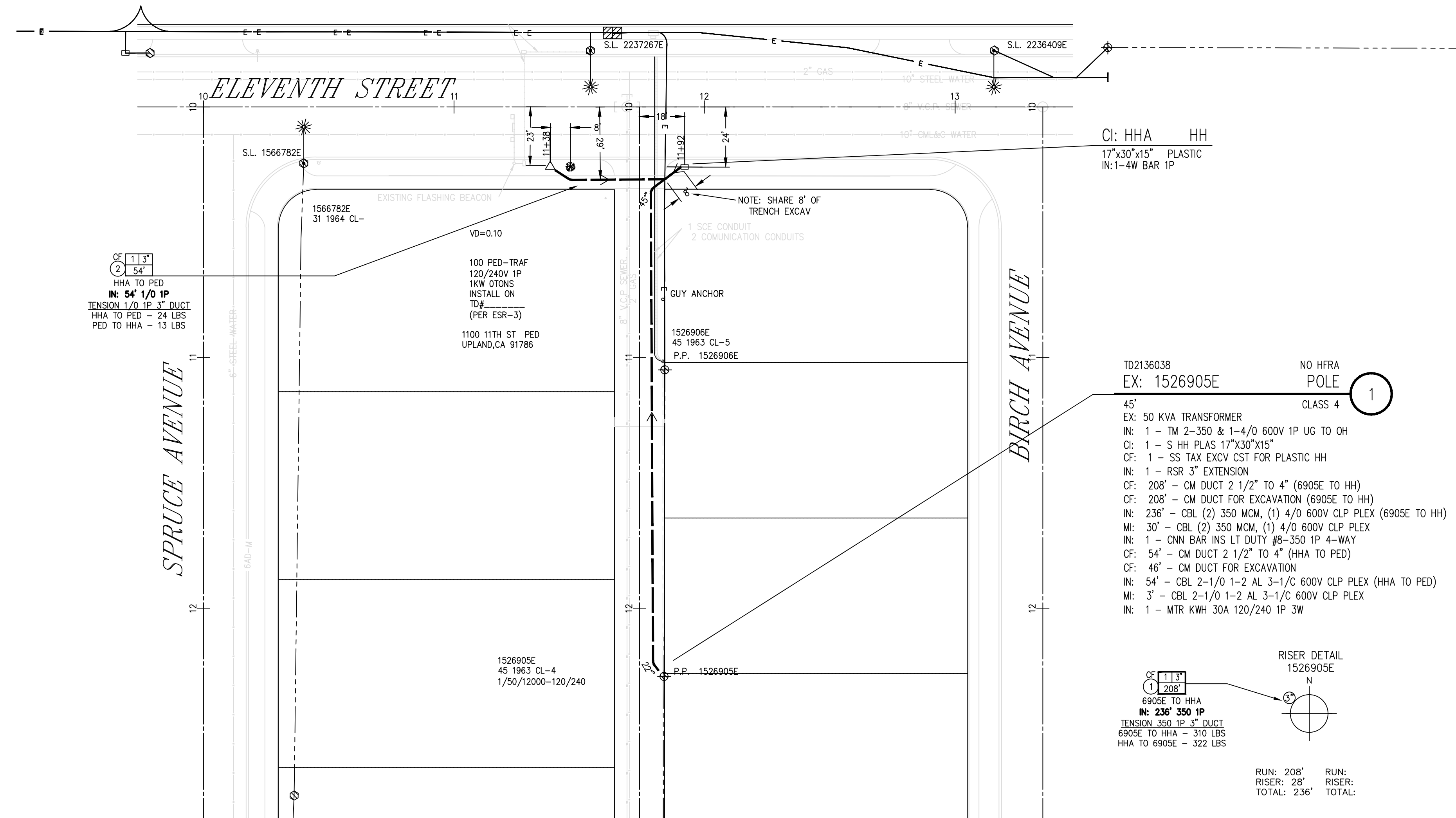

T.L.M. DATA: 1526905E

SIZE	KVA	CUST	% LOAD
EXIST. 50	48.4	17	97%
PROP. 50	49.6	18	99%

VOLTAGE DROP: .10%  
FLICKER FACTOR: —  
PRI. CIRCUIT: MEAGAN 12KV  
027: REV. 12/10/21

TD2136038  
EX: 1526905E  
NO HFRA  
POLE CLASS 4  
1

45'  
EX: 50 KVA TRANSFORMER  
IN: 1 - TM 2-350 & 1-4/0 600V 1P UG TO OH  
CL: 1 - S HH PLAS 17"x30"x15"  
CF: 1 - SS TAX EXCV CST FOR PLASTIC HH  
IN: 1 - RSR 3" EXTENSION  
CF: 208' - CM DUCT 2 1/2" TO 4" (6905E TO HH)  
CF: 208' - CM DUCT FOR EXCAVATION (6905E TO HH)  
IN: 236' - CBL (2) 350 MCM, (1) 4/0 600V CLP PLEX (6905E TO HH)  
ME: 30' - CBL (2) 350 MCM, (1) 4/0 600V CLP PLEX  
IN: 1 - CMN BAR INS LT DUTY #8-350 1P 4-WAY  
CF: 54' - CM DUCT 2 1/2" TO 4" (HHA TO PED)  
CF: 46' - CM DUCT FOR EXCAVATION  
IN: 54' - CBL 2-1/0 1-2 AL 3-1/C 600V CLP PLEX (HHA TO PED)  
ME: 3' - CBL 2-1/0 1-2 AL 3-1/C 600V CLP PLEX  
IN: 1 - MTR KWH 30A 120/240 1P 3W

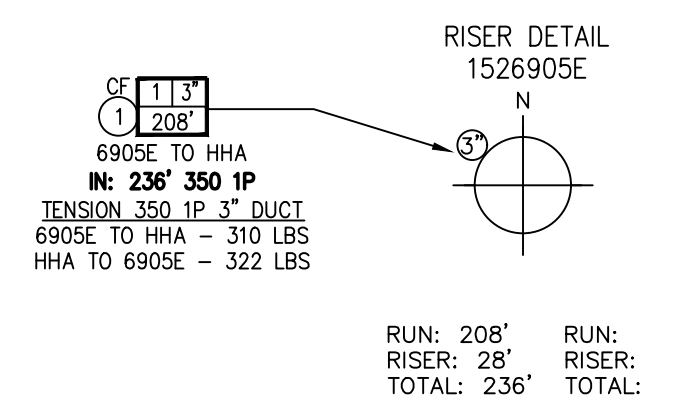

PROJECT REQUIREMENTS (Y/N)

EDISON EASEMENT REQUIRED	<input type="checkbox"/>
PWRD 88 REQUIRED	<input type="checkbox"/>
UG CIVIL ONLY WORK ORDER	<input type="checkbox"/>
PERMIT REQUIRED	<input checked="" type="checkbox"/>
PERMIT TYPE: TRAFFIC	
OUTAGE REQUIRED	<input type="checkbox"/>
OUTAGE DATE: _____ TIME: _____	
TRAFFIC CONTROL REQUIRED	<input checked="" type="checkbox"/>
PED. TRAFFIC CONTROL REQ'D	<input type="checkbox"/>
CONVEYANCE LETTER REQ'D	<input type="checkbox"/>
ENVIRONMENTAL REQUIREMENTS DOCUMENT (ERD) REQUIRED	<input type="checkbox"/>
CSD 140 (TLM) REQ'D	<input checked="" type="checkbox"/>
CIRCUIT MAP CHANGE REQ'D (TD 203)	<input type="checkbox"/>
DIG ALERT APP	<input type="checkbox"/>
VERIFIED ACTIVE AND CONFIRMED USA TICKETS	<input type="checkbox"/>
UTILIQUEST NOTIFIED	<input type="checkbox"/>
STANDARD ADHERENCE: 3rd Q/2023 Y	



**FINAL DESIGN**  
APPROVED FOR CONSTRUCTION

CREW/PSPEC NOTES:  
-TRUCK ACCESS OK  
-SIMPLE VENDOR TC REQUIRED FOR ALLEY WAY  
-INSTALL NEW SEC INTO HH, THEN METER/SVC INTO CITY PED

DISTRICT 34 - ONTARIO	PROJ. MGR. JOHNSON, TIMOTHY 661-726-5691	PLANNER JOHNSON, TIMOTHY 661-388-3076	DESIGNER PONCE, NANCY PATRICIA
PROJECT NO. 2611830	SERVICE REQUEST 3499739	MSR NO. 2136038-LINE EXTENSION	ASSOC DESIGN
CIRCUIT / VOLTAGE MEAGAN 12KV	GPS	PRODUCT-2	ASSOC DESIGN
SUB / PG NO. UPLAND SUB	CIRCUIT CODE	PRODUCT-3	ASSOC DESIGN
INVENTORY MAP	J.P.A. NO.	PROPOSED CONSTRUCTION (LOCATION)	
		LINE EXTENSION	
		1100 11TH ST	
		UPLAND CA 91786	
DATE 8-24-23	APPROVED BY T. JOHNSON	CHECKED BY N. PONCE	DRAWN BY N. PONCE
DATE 6-13-23	APPROVED BY T. JOHNSON	CHECKED BY N. PONCE	DRAWN BY N. PONCE
TYPE	DATE	APPROVED BY	CHECKED BY
Southern California Edison Company			SHEET 2 of 2
			DESIGN/DRWG NO. 1629402_1.01

FILE NAME: 1629402\_1.01.DWG DATE: 6/24/2023 1:52 PM SAVED BY: P. JOHNSON



## **APPENDIX "H"**

# **FLASHING BEACON IMPROVEMENTS DATA SHEETS**

**FOR**

---

**PROJECT Nos. 7031, 85003, & 86004  
BID No. 2024-05  
11TH STREET FLASHING SIGNAL BEACON &  
ALLEY IMPROVEMENTS**

---



Replace

Signal Pole to Remain

Remove and replace cabinet equipment

# R829-G

## Cabinet-Based School Zone Flashing Beacon Data Sheet

1.844.412.8395 | traffic@carmanah.com | carmanah.com



### CABINET DIMENSIONS

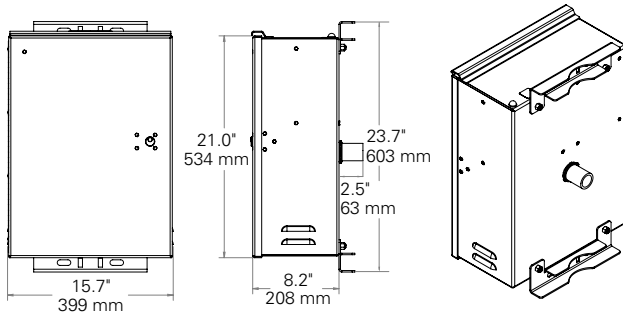

### SOLAR PANELS AND MOUNTS

3.5" - 4.5" Diameter Round  
Top of Pole Mount

Side of Pole Mount

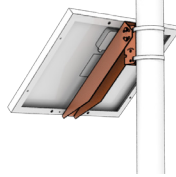
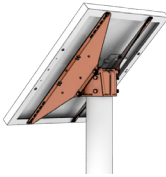

PANEL*	LENGTH	WIDTH
20 W**	18.5" (470 mm)	13.6" (345 mm)
50 W	26.3" (668 mm)	21.2" (538 mm)
80 W	30.7" (780 mm)	26.5" (672 mm)

\* Carmanah will conduct a site assessment and provide an Solar Power Report™ to determine the correct solar panel and battery size.

\*\* Only available in a Side of Pole configuration.

### BEACON MOUNTING

Dual Beacon

Quad Beacon



### BEACON SPECIFICATIONS

Optical	MUTCD compliant: 2009 MUTCD, Chapter 4L, Flashing Beacons, Manual on Uniform Traffic Control Devices (MUTCD)
	ITE VTCSS-LED Circular Signal Supplement compliant: meets ITE or 1.7x ITE intensity when used as recommended
	12 in (305 mm) or 8 in (203 mm) diameter LED modules, yellow
	High-power LEDs: +90% lumen maintenance (L90) based on IES LM-80
	Yellow, black, or green signal heads in UV-resistant polycarbonate or aluminum

### SYSTEM SPECIFICATIONS

On-Board User Interface (OBU)	Adjustable system settings with auto-scrolling LED display on our latest EMS
	System test, status, and fault detection: battery, solar, button, beacon, radio, day/night
	Flash patterns: RFB (WW+S), RFB1 (WW+S legacy), RFB2 (WSDOT), 0.5 sec. alternating (MUTCD), 0.5 sec. unison (MUTCD), 0.5 sec. x3 alternating (MUTCD), 0.1 sec. unison, 0.25 sec. unison, 0.1 sec. x3 quick flashes unison, 0.1 sec. x3 quick flashes alternating, steady on
	Input: momentary for pushbutton activation, normally open switch, normally closed switch, dusk-to-dawn operation
	Flash duration: 5 sec. to 1 hr.
	Intensity setting: 20 to 1400 mA for multiple circular beacons, RRFBs, or LED enhanced signs
	Nighttime dimming: 10 to 100% of daytime intensity
	Ambient Auto Adjust: increases intensity during bright daytime
	Automatic Light Control: reduces intensity if the battery is extremely low
	Temperature correction: yellow beacons
Beacon Communication	Calendar: internal time clock function
	Radio settings: enable/disable, selectable channel from 1 to 14
	Output: enabled when beacons flashing daytime and nighttime, or nighttime only E.g., for relay control of overhead lighting
	Activation counts and data reporting via OBU or optional USB connection
	Optional encrypted, wireless radio with 2.4 GHz mesh technology
	Optional radio allows calendar program, manual override switch, or input device from one system to remotely control other systems
	User-selectable multiple channels to group different beacons and ensure a robust wireless signal
	Instantaneous wireless activation: <150 ms
	Wireless range: 1000 ft (305 m)
	Integrated, vandal-proof antenna
Power System	Solar or <b>AC-powered</b>
	AC: 100-240 VAC input, 6-14 AWG Replaceable AC-DC power supply, circuit breaker, terminal block wiring
Energy Collection	20, 50, or 80 W high-efficiency photovoltaic solar panel
	45 deg tilt for optimal energy collection Maximum Power Point Tracking with Temperature Compensation (MPPT-TC) battery charger for optimal energy collection in all solar and battery conditions
Energy Storage	12 V battery system with multiple sizes: 35, 55, 100 Ahr.
	Replaceable, recyclable, sealed, maintenance-free, best-in-class AGM batteries offer the widest temperature range and longest life Battery design life: +5 yrs.
Cabinet Construction	Weatherproof, gasketed enclosure with vents for ambient air transfer (NEMA 3R)
	Lockable, hinged door with #2 lock Optional padlockable latch
	Corrosion-resistant aluminum with stainless steel hardware
	Raw aluminum finish or yellow, black, or green powder coated Prewired to minimize installation time
Environmental	High-efficiency optics and EMS = the most compact, lightweight system
	-40 to 165° F (-40 to 74° C) system operating temperature -40 to 162° F (-40 to 72° C) battery operating temperature
	150 mph (241 kph) wind speed as per AASHTO LTS-6
Activation	Internal time clock: calendar programming via our simple software
	Also compatible with 3rd-party time clocks: <ul style="list-style-type: none"> <li>Applied Information AI 500-070B</li> <li>Temple FCU 500-071 (FL only)</li> <li>RTC AP21, AP22, CPR2102, and M2M modem</li> </ul> Other time clocks may also be compatible.
	Manual override switch: allows local control of beacons
	Junction box: lockable, hinged door, corrosion-resistant aluminum enclosure allows easy calendar programming and access to manual override switch
<b>Warranty</b>	<b>5-year limited warranty, 1-year limited on batteries</b>

**Specifications subject to local environmental conditions, and may be subject to change.**

All Carmanah products are manufactured in facilities that are certified to ISO quality standards.

"Carmanah" and Carmanah logo are trademarks of Carmanah Technologies Corp.

© 2021, Carmanah Technologies Corp.

Document: DATA\_TRA\_R829-G\_RevJ

# AI-500-070 School Beacon Timer Switch and Cellular Modem

## Overview

The AI-500-070 series provides a cost-effective, easy to integrate means of adding monitoring and control to School Beacons Flashers. It is designed for extreme temperature applications and has low power requirements, making it suitable for solar powered applications. The simple Integrated School Beacon Timer Switch and Cellular Modem can be retrofitted into existing School Beacon cabinets to upgrade the school beacons to the latest technology.

The unit provides an easy way to monitor the school beacons status and health such as AC power, battery backup, monitor beacon current, cabinet door open, local override control and radar speed information.

The unit works in conjunction with the Glance Platform, providing a cloud-based School Beacon solution. Simply connect the unit to your school beacons to add monitoring and control to your equipment. The unit allows you to remotely configure schedules for the school beacons from the Glance cloud based software.

## Features

- ✓ Low cost Internet connectivity solution
- ✓ Low power consumption
- ✓ Compatible with Glance platform
- ✓ GPS enabled for self-locating
- ✓ Monitor beacon lamps current to determine when a beacon has failed
- ✓ Remotely change schedule to multiple devices
- ✓ Remotely monitor radar speed of vehicles
- ✓ Email & text messages when faults are detected
- ✓ Integral battery back-up for power fail reporting
- ✓ Local manual override switch
- ✓ Remote firmware updates available



Call us today to get started at [678.830.2170](tel:678.830.2170) or email us at [sales@appinfoinc.com](mailto:sales@appinfoinc.com)!

# Hardware Specification



AI-500-070

## Connectivity

Cell Modem	Yes
Ethernet Port (10/100Base-T)	Yes
RS-232 Port	Yes

## Industrial I/O

Analog Inputs	AC Power, Solar Batteries & Temperature
Digital Inputs	Beacon Status & Door Open Switch
Digital Outputs	2 X Beacon Circuits

## Miscellaneous

Operating Systems	µC/OS-II
GPS	Yes
Operating Temperature	-37°C to 74°C
Humidity	5-95% non-condensing
Dimensions	8" x 5" x 2"
Input Voltage	10-30v DC, 120V AC
Power Consumption DC	idle - 149mA avg; active - 212mA avg
Power Consumption AC	idle - 17mA avg; active - 24mA avg
Battery Backed Memory	Yes

## Also suitable for...

Solar/battery powered	Yes
Lamp Monitoring	Yes
Scheduling	Yes

\*\* Custom configurations available for volume orders



Project	Project Location
School Zone Flashers	City of Upland

Qty	Item	Description	Amount
2	84569	R829-G AC cabinet	
4	84296	LED module 12in Round Yellow	
4	12" FULL CIRCLE VISOR	MAT [X] W/ 12" FULL CIRCLE VISOR **LED NOT INCLUDED DOES NOT INCLUDED 2" REFLECTIVE TAPE ON BACKPLATE  ALUMINUM HOUSING FULL CIRCLE VISORS L.E.D.S ARE FURNISHED BY OTHERS ALUMINUM BACKPLATES STANDARD CALTRANS COLORS (GREEN/BLACK) CALTRANS FRAMEWORK WITH BRONZE TERMINAL COMPARTMENTS	
2	84366	LED or Push button harness 16ft	
2	84367	LED or Push button harness 36ft	
2	84598	Applied Information monitoring unit kit incl. harness door switch mount no monitoring unit	
2	AI-500-070B	School Timer Switch & Cell (Carmanah only)	
2	AI-GLANCE-ONE-TIME	Glance Software- one-time subscription, per device- covers perpetual Glance software and support license costs, hosted on the cloud.	
2	AI-GLANCE-CONFIG	Configuration Charge, per device. Includes setting up all inputs, labels, thresholds, alarms and alerts. (non taxable)	
2	AI-SB-5 Year	School Beacon and PCSS Monitoring, 5 Year Connectivity and Support	